

Simulation And Analysis of DSTATCOM

¹ Kartik Parmar ² Pratik Kabrawala ³ Prof. Pinkal J. Patel

^{1,2} PG student ³ Associate Prof.

Department of Electrical Engineering

Sankalchand Patel College Of Engineering, Visnagar (GUJARAT-INDIA)

Kpparmar.42@gmail.com, pk10587@gmail.com , pjpatel.ee@spcevng.ac.in

Abstract- This paper presents the simulation and analysis of DSTATCOM for voltage sag mitigation and then harmonics distortion and power factor improvement using LCL passive filter with DSTATCOM in distribution system. The model, based on 2-level voltage source converter which requires only voltage measurements and reactive power measurements are not required. The operation of simulated control method for DSTATCOM (Distribution Static Synchronous Compensator) in MATLAB SIMULINK R2009b.

Index term-DSTATCOM, VSC (Voltage Source Converter), LCL Passive Filter, THD (Total Harmonics Distortion).

I. INTRODUCTION

Recently there is a great need to improve power utilization and maintaining power system security and reliability in highly complex and inter connected power system. It is affected under loading and overloading of lines power flow in the system. As a result of this there arises a problem of deteriorating voltage profile and power system stability. Therefore finally power quality, which is one of the most important factors nowadays. Power quality is one of major concerns in the present era. It is needed to introduce sophisticated devices whose performance is very sensitive to power quality supply. Power quality problem is due to nonstandard voltage, current or frequency that results in a failure of end use equipments. One of the major problems here are the voltage sags.

Voltage sag is caused by the fault in the utility system or a large increment in load current. Such faults may be single-phase or multi-phase short circuits which result in high currents. Voltage sags are one of the most power quality problems. For an industry voltage sags occur often which create severe problems and economical losses. Utilities always concentrate on disturbances from end-user equipment as the main power quality problems.

In distribution system, Harmonic currents can cause harmonic distortion, low power factor and additional losses as well as heating in the electrical equipment. Due to these problems vibration and noise in machines and malfunction of the sensitive equipment. The development of power electronics devices such as Flexible AC Transmission System (FACTS) and custom power devices have introduced and emerging branch of technology providing the power system with versatile new control capabilities [1]. There are many ways to enhance power quality problems in transmission and distribution systems. Among these, the D-STATCOM is one of the most effective devices. A new PWM-based control technique has been implemented to control the DSTATCOM. The D-STATCOM is capable to sustain reactive current at low voltage, and can be developed as a voltage and frequency support by replacing capacitors with batteries as energy storage.

In this paper DSTATCOM, PWM control VSC based is connected in parallel to the 11 kV test distribution system which simulated with LCL Passive Filter and analyzed. It improves the power quality such as voltage sags, harmonic distortion and low power factor in distribution system.

II. DSTATCOM (DISTRIBUTION STATIC SYNCHRONOUS COMPENSATOR)

The D-STATCOM consists a VSC, a dc energy storage device; a coupling transformer connected in parallel to the ac system and associated controller circuits. Fig 2.1 shows the basic configuration of D-STATCOM. The VSC converts the dc voltage across the storage device into ac output voltages. These ac voltages are in phase and coupled with the ac system through the reactance of the coupling transformer. Inverter is the main component of the D-STATCOM. The three basic operation modes of the DSTATCOM output current I_{out} which varies depending upon V_i . If V_i is equal to V_s than the reactive power is zero and the D-STATCOM does not generate or absorb reactive power. When V_i is greater than V_s , the D-STATCOM shows an inductive reactance connected at its terminal. The current flows through the transformer reactance from the D-STATCOM to ac system and the device generates capacitive reactive power. If V_s is greater than V_i , the D-STATCOM shows the system as a capacitive reactance. This time the current flows from the ac system to the D-STATCOM which results absorbing inductive reactive power. Where V_s is system voltage and V_i is inverter voltage.

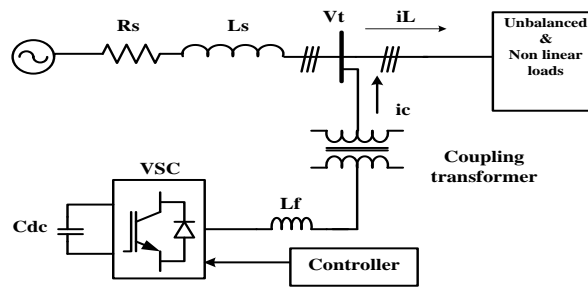

Fig.2.1 Basic DSTATCOM

Some Suitable adjustment of the phase and magnitude of the D-STATCOM output voltages allows effective control of active and reactive power exchanges between the D-STATCOM and ac system. The VSC connected in shunt to ac system provides a multifunctional topology which can be used for three quite distinct purposes ^[3]:

- 1) Voltage regulation and compensation of reactive power
- 2) Correction of power factor
- 3) Elimination of current harmonics.

The control system design determines the priorities and functions developed in each case. The D-STATCOM regulates voltage at the point of connection. The control of DSTATCOM is based on sinusoidal PWM which requires voltage measurements and no reactive power measurements.

III. VSC (VOLTAGE SOURCE CONVERTER)

A VSC as a power electronic device is most important in DSTATCOM which can generate a sinusoidal voltage with any required magnitude, frequency and phase angle. Voltage source converters are widely used in ASD(Adjustable-Speed Drives), but can also be used to mitigate voltage dips. The VSC is used completely to replace the voltage or to inject the 'missing voltage'. The missing voltage is the difference between the nominal voltage and the actual. The converter is normally based on some kind of energy storage, which will supply the converter with a DC voltage ^[4,5]. DC source as battery is connected parallel to the DC capacitor. It carries the input ripple current of the converter and it is the main reactive energy storage element. This DC capacitor could be charged by a battery source or could be recharged by the converter itself. The switching strategy based on a sinusoidal PWM method which offers simplicity and good response.

IV. CONTROLLER

The main aim of the control scheme is to maintain constant voltage magnitude at the point where a sensitive load is connected, under system disturbances. In this control scheme it measures the RMS voltage at the load point and no requirements of reactive power measurements. Here the sinusoidal PWM technique is used for the switching of VSC offers simplicity and good response. The input of the controller is an error signal which is obtained from the reference voltage and the value RMS of the terminal voltage measured at load point. Then PI controller will process this error signal and then the output is the angle δ which is given to the PWM signal generator. The PWM generator generates the sinusoidal PWM waveform or signal. The angle of output of PI summed with phase angle of the balanced supply voltages which is assumed to be 120° to produce the desired synchronizing signal, required to operate the PWM generator. Now the error signal by comparing reference voltage with the RMS voltage measured at the load point is processed by PI controller which in return generates the required angle to drive the error to zero, i.e., the load RMS voltage is brought back to the reference voltage. In this scheme the DC voltage is maintained constant using a separated dc source ^[4]. Basic block of this theory is given in fig 4.1.

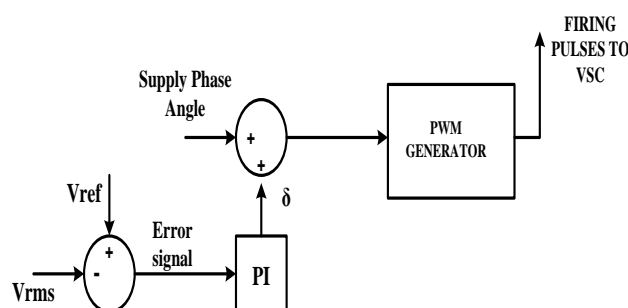

Fig 4.1 Phase Shift control scheme

The sinusoidal signal $V_{control}$ is phase-modulated by means of the angle δ .

$$\begin{aligned} \text{i.e., } V_A &= \sin(\omega t + \delta) \\ V_B &= \sin(\omega t + \delta - 2\pi/3) \\ V_C &= \sin(\omega t + \delta + 2\pi/3) \end{aligned}$$

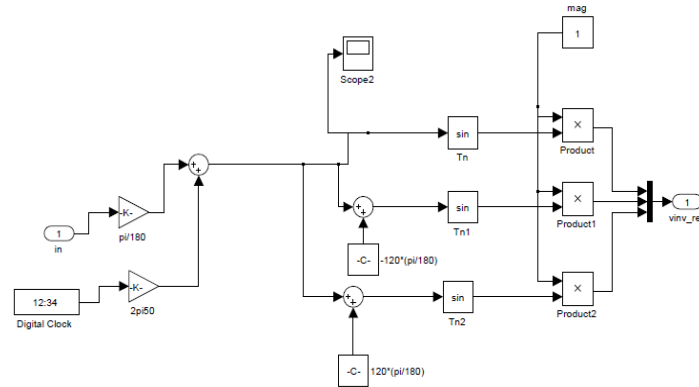

Fig.4.2.Phase Modulation of Control Angle

To generate the switching signals for the VSC valves, the modulated signal $V_{control}$ is compared against a triangular signal. The amplitude modulation index of signal and the frequency modulation index of the triangular signal are the main parameters of the sinusoidal PWM scheme [3,4]. Complete compensation is not achieved in case of nonlinear load though this strategy is easy to implement and is robust and can provide partial reactive power compensation without harmonic suppression [17]. Using LCL passive filter with DSTATCOM harmonics can be suppress.

V. SIMULATION

The test system is shown in figure 5.1 consist a 230kv, 50 Hz transmission system which is fed into the primary side of a 3-winding transformer connected in Y/Y/Y,230/11/11kv. A varying load is connected to 11kv, secondary side of transformer. A two level DSTATCOM is connected to 11kv tertiary winding to provide voltage support at point of common coupling. On dc side Capacitor of 750 μ F provides the DSTATCOM energy storage capabilities. Breakers are used to control the operation of DSTATCOM and LCL passive filter.

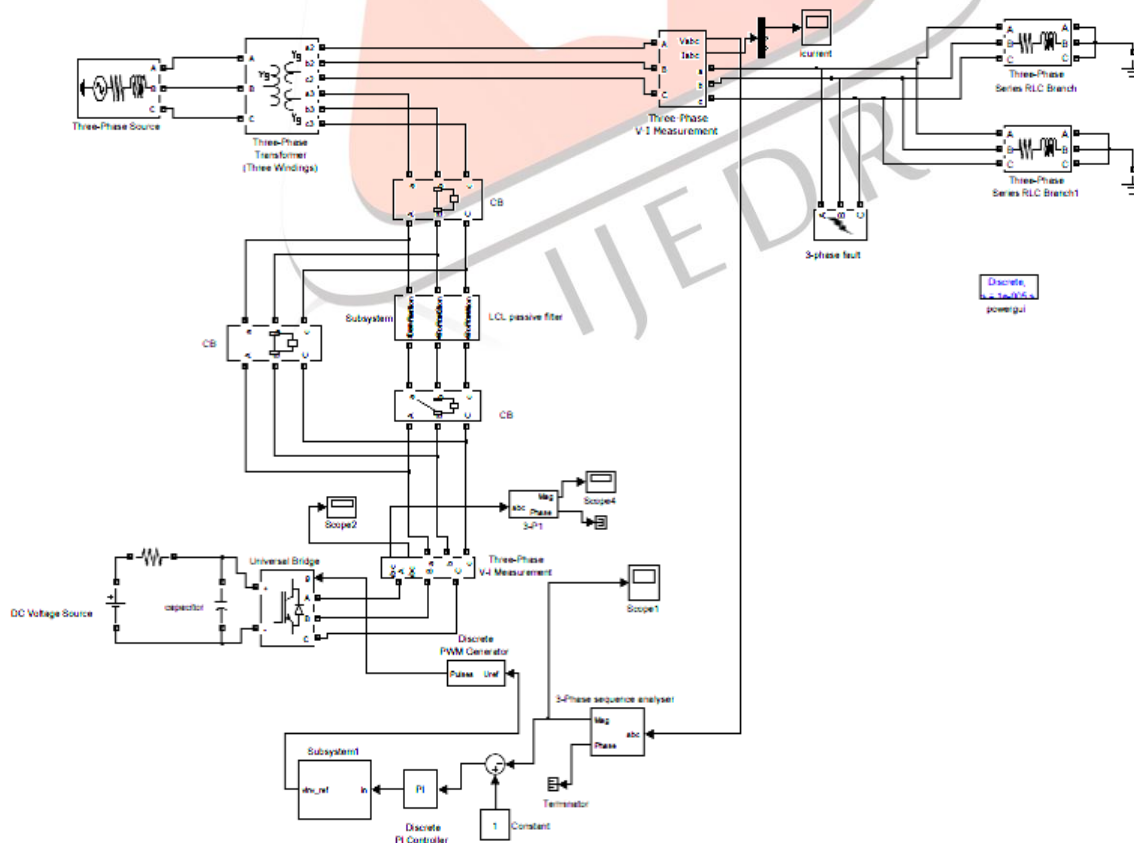

Fig.5.1 Test system of DSTATCOM

The test system is simulated in MATLAB simulink as per given figure in. To make distortion in distribution system like voltage sags, different types of faults such as Single Line to Ground (SLG), Line to Line (LL), Double Line to Ground (DLG) and Three Phase to Ground (TPG) are injected.

(A) Without insertion of DSTATCOM

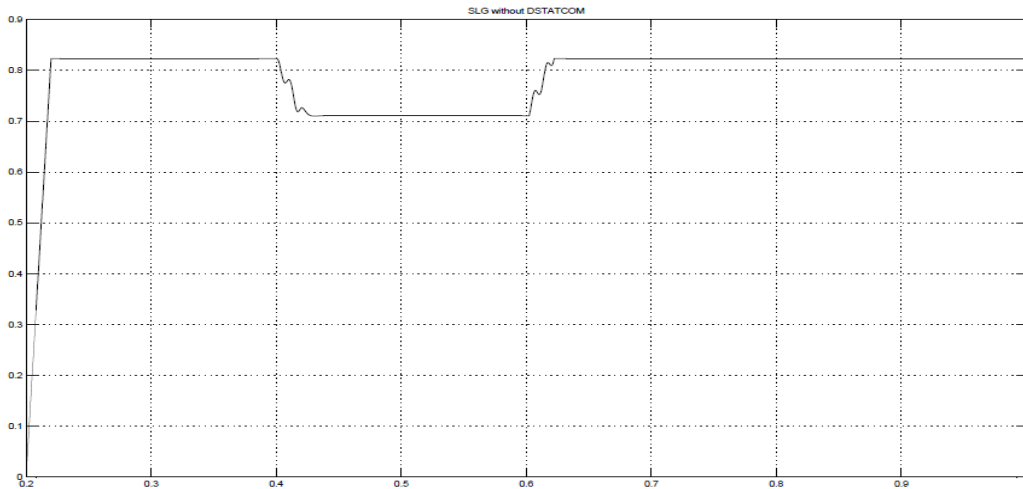

Fig.5.2(a) voltage sag at load point is 0.8232 p.u. using SLG

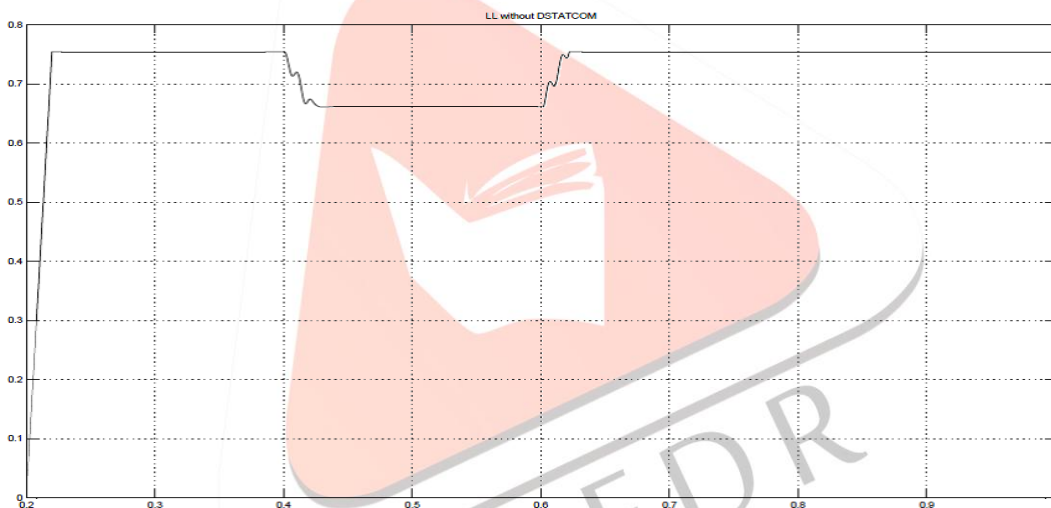

Fig.5.3(b) voltage sag at load point is 0.7546 p.u. using LL fault

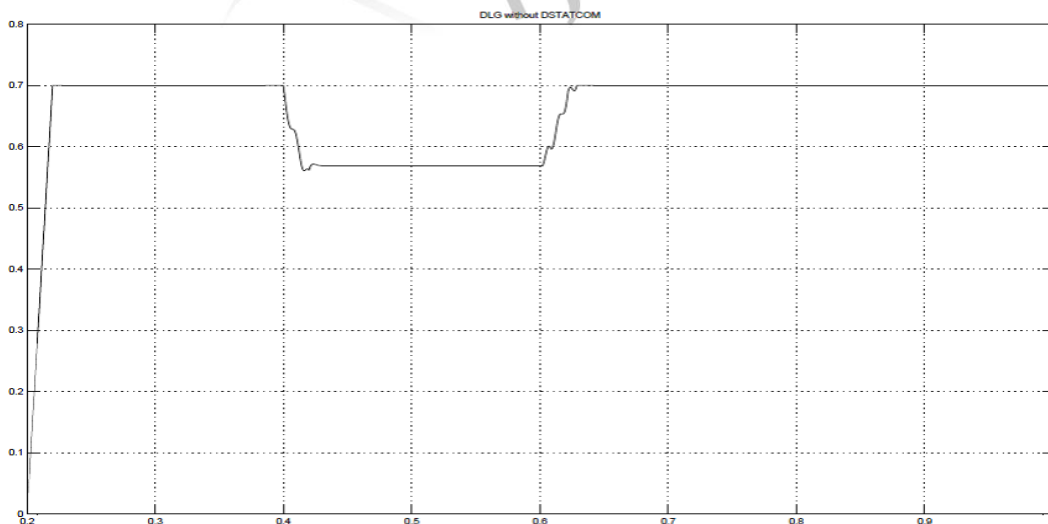

Fig.5.4(c) voltage sag at load point is 0.7001 p.u. using DLG fault

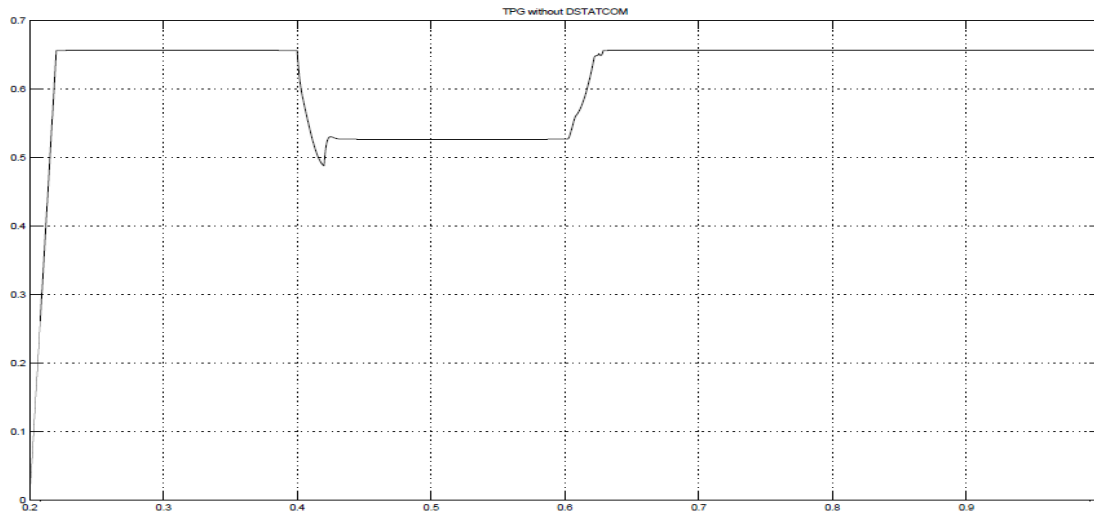

Fig.5.5(d) voltage sag at load point is 0.6564 p.u. using TPG fault

Figure 5.2(a) to 5.5(d) show the simulation results of the test system for different faults without DSTATCOM with fault resistance $R_f=0.66\Omega$.

TABLE 5.1.RESULTS OF VOLTAGE SAGS FOR DIFFERENT FAULTS

FAULT RESISTANCE $R_f\Omega$	VOTAGE SAG FOR SLG FAULT	VOTAGE SAG FOR LL FAULT	VOTAGE SAG FOR DLG FAULT	VOTAGE SAG FOR TPG FAULT
0.66	0.8232	0.7546	0.7001	0.6564
0.76	0.8461	0.7876	0.7411	0.7093
0.86	0.8637	0.8199	0.7827	0.7480

Table 5.1 shows the overall results of voltage sags in p.u. for different faults. It can be observed from the table that when the value of fault resistance is increase, the voltage sags will also increase for different faults.

(B)With insertion of DSTATCOM

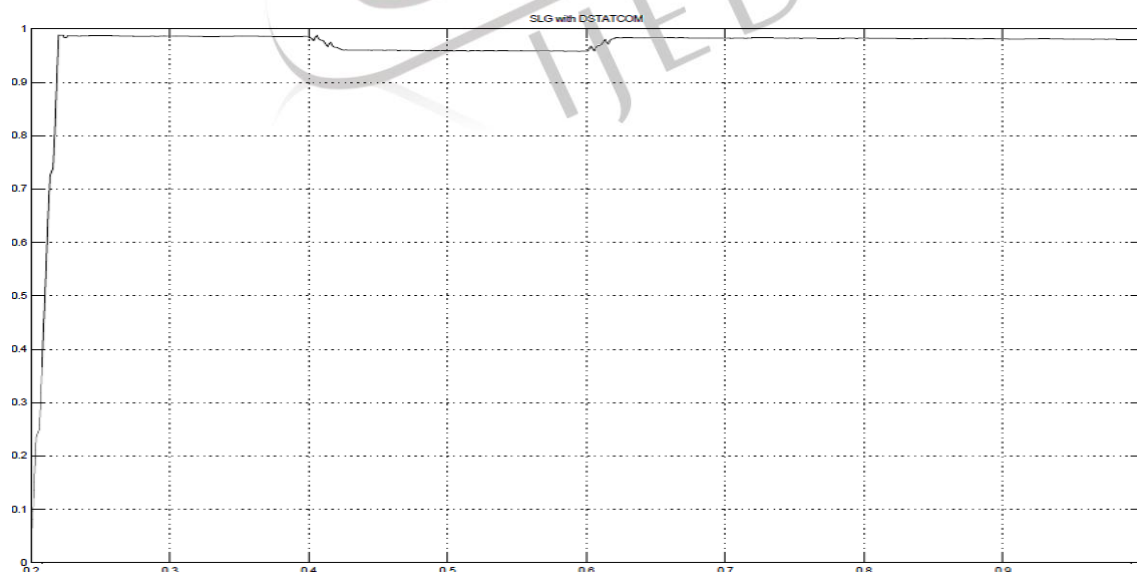

Fig.5.6(e) voltage sag at load point is 0.9807 p.u. at SLG fault

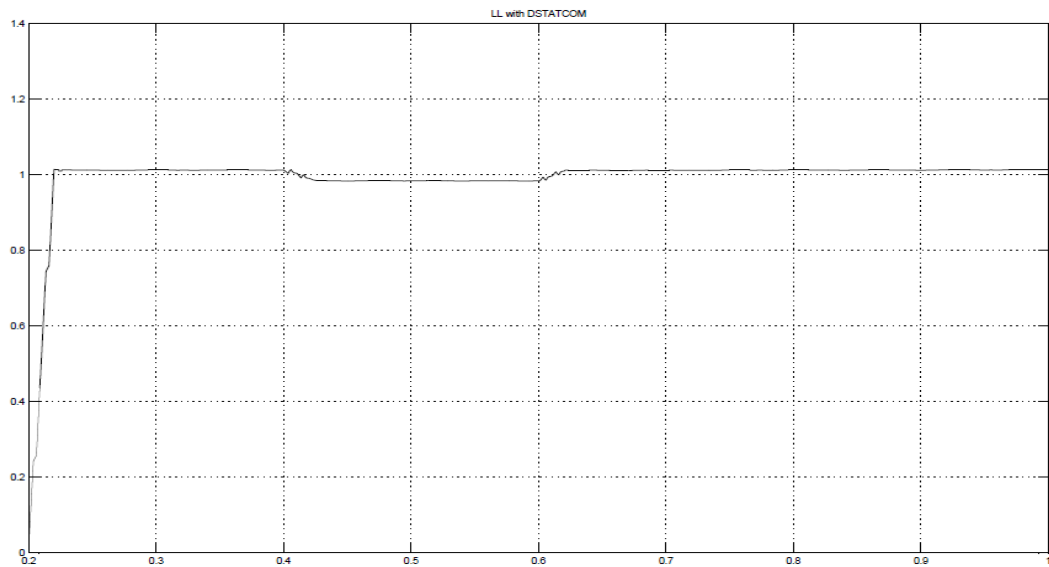

Fig.5.7(f) voltage sag at load point is 0.1014 p.u. at LL fault

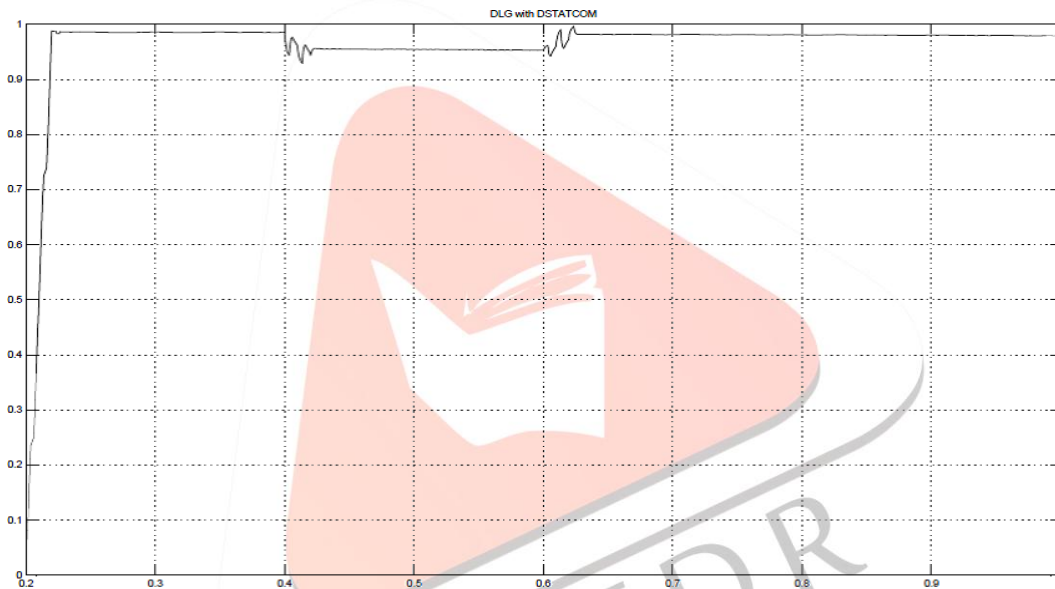

Fig.5.8(g) voltage sag at load point is 0.9790 p.u. at DLG fault

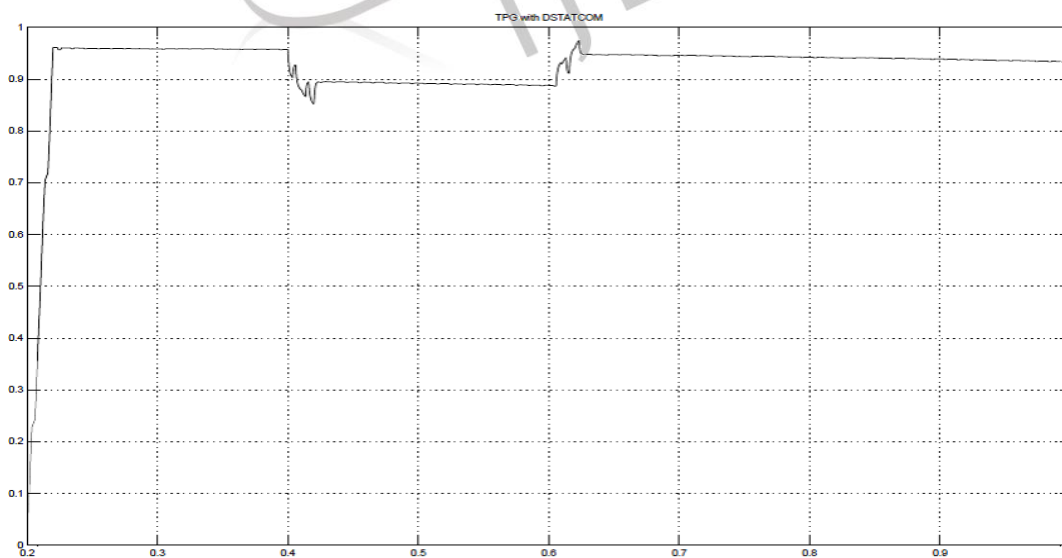

Fig.5.9(h) voltage sag at load point is 0.9343 p.u. at TPG fault

Figure 5.6(e) to 5.9(h) show the simulation results of the test system for different fault with DSTATCOM with fault resistance $R_f = 0.66\Omega$.

TABLE 5.2 RESULTS OF VOLTAGE SAGS FOR DIFFERENT FAULTS

FAULT RESISTANCE R_f, Ω	VOTAGE SAG FOR SLG FAULT	VOTAGE SAG FOR LL FAULT	VOTAGE SAG FOR DLG FAULT	VOTAGE SAG FOR TPG FAULT
0.66	0.9807	1.0140	0.9790	0.9343
0.76	0.9813	1.0151	0.9798	0.9405
0.86	0.9823	1.0169	0.9833	0.9519

Table 5.2 shows the overall results of voltage sags in p.u. for different fault. It can be observed from the table that when DSTATCOM is inserted in system, voltage sags improved and values of sags between 0.9 to 1.02 with fault resistance R_f .

(C) DSTATCOM without LCL passive filter

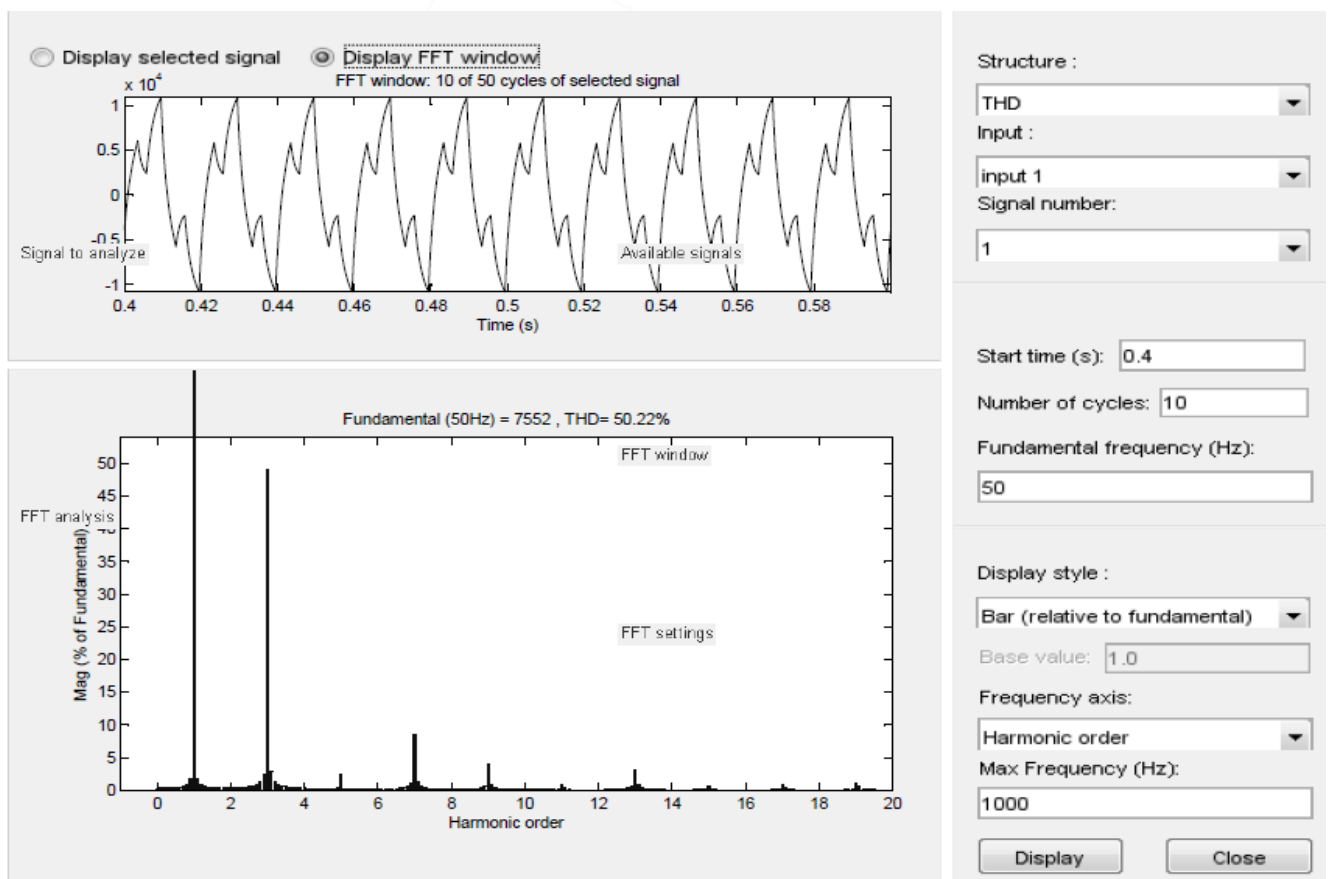

Fig.5.10 Waveform of distortion output current FFT without LCL passive filter and harmonic spectrum

Figure 5.10 shows the current harmonic for different types of faults and the percentage of THD shows that which is not within the IEEE STD 519-1992 and also poor power factor. THD in system without LCL passive filter is 50.22%.

(D) DSTATCOM with LCL passive filter

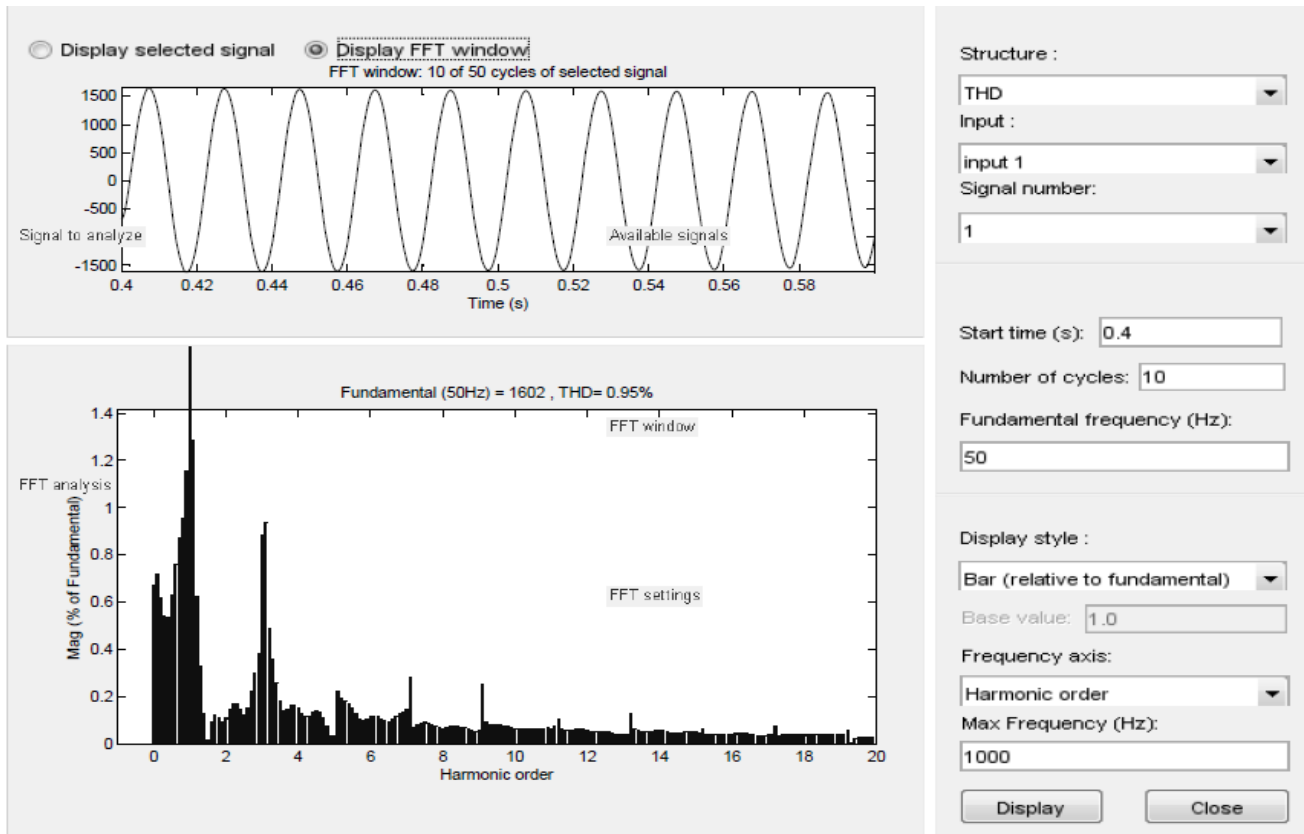

Fig.5.11 Waveform of output current with LCL passive filter and harmonic spectrum

Figure 6.2 shows the waveform of output current which is sinusoidal with LCL passive filter and the percentage of THD that is reduced to the IEEE STD 519-1992 and also increase power factor. THD in the system with LCL passive filter is 0.95%. Here LCL Passive filter is more effective on reducing harmonic distortion. To design it, given below equations are used^[4].

$$L_g = \frac{E_n}{2\sqrt{6}i_{ripm}f_{sw}} \dots\dots(5.1)$$

$$L_c = \frac{L_g}{2} \dots\dots\dots(5.2)$$

$$C_f = \frac{L + L_g}{LL_g(2\pi f_{res})^2} \dots\dots(5.3)$$

Where E_n =RMS value of grid voltage, L_g =Grid-side filter inductance, L_c =Converter-side filter inductance, C_f =Filter capacitance, i_{ripm} =peak value fundamental Harmonic current, f_{sw} =Switching frequency, f_{res} =Resonance frequency.

VI. CONCLUSION

The simulation results give that voltage sags can be reduced by inserting DSTATCOM in the distribution system. After adding the LCL passive filter to system, the THD is reduced to IEEE STD 519-1992 and power factor increased. Thus it can help to improve power quality in distribution system by inserting DSTATCOM with LCL passive filter.

REFERENCES

- [1] M.G. Molina and P.E. Mercado, "Control Design and Simulation of DSTATCOM with Energy Storage for Power Quality Improvements", IEEE Transactions on Power Delivery, June 2006.
- [2] Noramin Ismail, WanNorainin Wan Abdullah, "Enhancement of Power Quality in Distribution System Using D-STATCOM", IEEE Transactions on Power Delivery, June 2010, pp.418-423.

- [3] Hirak K. Shah, P.N. Kapil, and M.T.Shah, "Simulation & Analysis of Distribution Static Compensator (D-STATCOM)", IEEE Transactions on Power Delivery, Dec 2011.
- [4] Hojat Hatami, Farhad Shahnia, Afshin Pashaei, S.H. Hosseini, "Investigation on D-STATCOM and DVR Operation for Voltage Control in Distribution Networks with a New Control Strategy", IEEE Transactions on Power Delivery, pp. 486-491.
- [5] Pradeep Kumar, "Simulation of Custom Power Electronic Device D-STATCOM - A Case Study", IEEE Transactions on Power Delivery 2011.
- [6] Sai Kiran Kumar Sivakoti, Y.Naveen Kumar, D.Archana, "Power Quality Improvement In Distribution System Using D-STATCOM In Transmission Lines", International Journal of Engineering Research and Applications (IJERA), Vol. 1, Issue 3, pp.748-752.
- [7] Archana M. Kadam, SatyenDhamdhare, D.S.Bankar , "Application of DSTATCOM for Improvement of Power Quality using MATLAB Simulation", International Journal of Science and Modern Engineering (IJISME) ISSN: 2319-6386, Volume-1, Issue-1, December 2012, pp. 9-13.
- [8] E.Rambabu, E.Praveena, Prof.P.V.Kishore,"Mitigation of Harmonics in Distribution System Using D – STATCOM", International Journal of Scientific & Engineering Research Volume 2, Issue 11, Nov-2011.

