

Minimization of Interference Using Different Equalization Techniques

¹Yogeshwari Y Ujalmbkar,²Sayad Shoaib Anwar
¹Student of Master of Engineering,²Assistant Professor
^{1,2}Department of Electronics and Tele Communication
 MGM's College of Engineering Nanded, India

Abstract - During past few years, demand for higher data rates is increasing day by day. The main problems in higher data rates are inter symbol interference and inter channel interference. To mitigate these challenges, different equalization techniques are used. Among all multiplexing techniques Orthogonal Frequency Division Multiplexing (OFDM) is proved to be best for achieving higher data rates.

This paper discusses different equalization techniques such as LS algorithm, MMSE algorithm by using OFDM for minimization of interference. The simulation results show that LS estimator gives better performance and lower complexity.

Index Terms - MMSE, LS, OFDM, minimization of interference.

I. INTRODUCTION

In wireless transmission the output is not the same signal transmitted but the combination of reflected, diffracted and scattered copies of the transmitted signal. This happens due to the interference while travelling. Another problem is fading. Fading is present where there are multipath components. Multipath components arrive at receiver at slightly different times. If movement in system occurs then there is phase difference between received components which leads to frequency shift. These multiple received copies form constructive or destructive interference to the signal. It creates standing wave pattern which shows rapid signal strength changes, frequency shifts or echoes. Orthogonal Frequency Division Multiplexing(OFDM) is most commonly employed in wireless communication systems because of the high data rate of transmission, high bandwidth efficiency. Though it has ability to combat against multipath delays it also suffers from fading. To minimize this interference different equalization techniques are used such as LS algorithm, MMSE algorithm etc. When the modulated symbol time is of the same order as that of channel delay spread, it leads to Inter-symbol interference (ISI). ISI is a major problem of any wireless communication systems. It can cause an irreducible error which degrades the system performance significantly. To mitigate ISI, equalization is performed on receiver side. Equalization is a filtering approach which minimizes the error between actual output and desired output by continuously updating its filter coefficients. It is generally used to combat ISI due to channels as well as due to transmitter and receiver filters. LS, MMSE algorithms are implemented in this paper.

The rest of the paper is organized as follows. In section II, system model used in this paper is discussed. In section III, various equalizer algorithms are shown along with their implementation issues. The simulation parameters and results are presented in section IV, and paper is concluded in section V.

II. SYSTEM MODEL

The transceiver structure of $M_T \times M_R$ MIMO OFDM system is shown in Fig. 1. Where, M_T and M_R are the number of transmitting and receiving antennas. Initially, the input bits are randomly generated. These input bits are mapped into data symbols by using different modulation techniques such as Binary Phase Shift Keying (BPSK), Quadrature Phase Shift Keying (QPSK), Quadrature Amplitude Modulation (QAM). Afterwards, serial to parallel converter (SPC) is used to convert the incoming serial stream into number of parallel substreams.

Number of parallel sub-streams will depend upon number of transmitting antennas i.e. M_T . The number of parallel streams are passed through IFFT block which converts the streams into time domain. After that cyclic prefix is inserted to minimize the interference. Again this parallel data is converted into serial data stream. The data symbols are transmitted simultaneously from M_T transmitting antennas and then passed through MIMO channel. Channel used in this paper is Rayleigh selective frequency fading channel. While passing through these channels Additive White Gaussian Noise (AWGN) gets added and the signal is contaminated with distortions like ISI and Inter-carrier interference (ICI). The information is received through M_R receiving antennas, which will serve as input to equalizer. At receiver side performed actions are exactly opposite to that performed at transmitter side to get the original signal as output.

Consider the transmission sequence as X_1, X_2, \dots, X_n . In normal transmission, X_1 will be transmitted in first time slot, X_2 in second time slot and X_n in n^{th} time slot.

Consider two antennas on both sides, then we can group the data symbols into group of two. In the first time slot, X_1 and X_2 is transmitted from the first and second antenna. In the second time slot, X_3 and X_4 is transmitted from the first and second antenna respectively. Thus, the received signals at receiver 1 and 2 can be expressed as

$$Y_1 = h_{11}x_1 + h_{12}x_2 + n_1 \quad (1)$$

$$Y_2 = h_{21} x_1 + h_{22} x_2 + n_2 \quad (2)$$

Where, n_1 and n_2 is additive white Gaussian noise

(AWGN) with zero mean and unit variance at receiver 1 and 2. h_{11} , h_{12} are channel impulse response (CIR) coefficients between receiver 1 and transmitter 1 and 2. Similarly, h_{21} and h_{22} are CIR coefficients between receiver 2 and transmitter 1 and 2. After combining

equation (1) and (2) the new equation is expressed as

$$Y_j = \sum_{i=0}^{L-1} h_{ji} * X_i + N_i \quad (3)$$

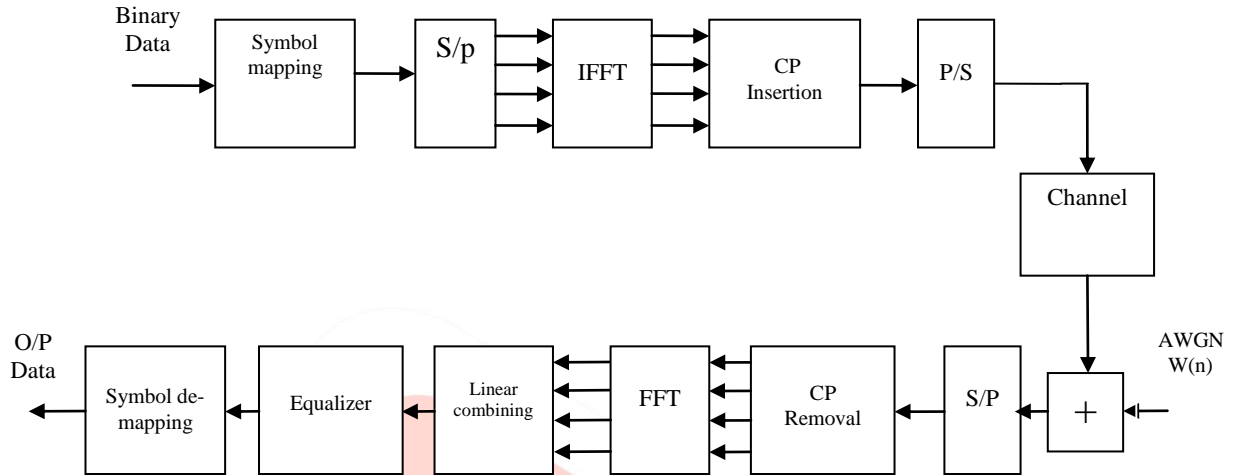

Figure 1 OFDM System Model

Where, Y_j is received signal at receiver antenna j . X_i and N_i are symbol vector and noise vector for M_T transmitting antennas. $h_{j,i}$ is channel response between transmit antenna i and receive antenna j . It can be expressed as

$$h_{j,i}(t) = \sum_{l=0}^{L-1} \alpha_{j,i}(l) \delta(t - \tau_l) \quad (4)$$

Where, α is complex path gains which can be modeled by Gaussian variables. L is the number of multipath between transmitter antenna i and receiver antenna j .

Equation (3) can also be expressed in matrix form as,

$$Y = HX + N \quad (5)$$

At the receiver, several replicas of the same signal may add up constructively or destructively which leads to multipath fading channels. These Multi-path fading channels are characterized by delay spread in time domain.

The channel models used in this paper are Rayleigh

Selective frequency channels. It means that we considered multi path channels without any single dominant path. The behavior of H is continuously varying due to a combination of inadequate antenna spacing and/or inadequate scattering which leads to spatial fading correlation. In the presence of an Line of Sight (LOS) component between transmitter and receiver, the MIMO channel may be modeled as the sum of a fixed component and a fading component.

$$H = \sqrt{\frac{K}{1+K}} \hat{H} + \sqrt{\frac{K}{1+K}} \hat{H}_f \quad (6)$$

Where, $\sqrt{\frac{K}{1+K}} \hat{H}$ is LOS component and

$\sqrt{\frac{K}{1+K}} \hat{H}_f$ is fading component of channel.

Here, k is Rician k -factor of the channel and it is nothing but the ratio of the power in the LOS component of the channel to the power in fading component. k is always greater than or equal to 0. When $k=0$, it means we have pure Rayleigh fading channel. In general, real-world MIMO channels will exhibit some combination of Rician fading and spatial fading correlation.

III. Equalization

ISI still exists due to multipath propagation channels, although CP is included. ISI caused by multipath within time dispersive channels will result into an irreducible error floor at the receiver. It severely affects the system performance when modulation symbol time is of the same order as that of channel delay spread. To mitigate this ISI equalization is incorporated on receiver side. Equalizer can be categorized as time and frequency domain equalizer depending on the domain in which it is applied. They can also be categorized as linear and non-linear depending upon usage of their output. Equalizers used in this paper are linear equalizers such as Least Square (LS), Minimum mean square error (MMSE).

Least Square Equalizer

The Least Squares Error (LSE) estimation method can be used to estimate the system $h[m]$ by minimizing the squared error between estimation and detection.

In matrix form, it can be written as

$$y = XH \quad (7)$$

So the error 'e' can be defined as

Error=Expected o/p- Actual o/p

$$e = y'' - y \quad (8)$$

Where y'' is the expected output.

Now, the squared error (S) can be defined as

$$\begin{aligned} S &= |e|^2 \\ S &= (y'' - y)^2 \\ S &= (y'' - y) * (y'' - y)^t \end{aligned} \quad (9)$$

Where, superscript 't' stands for complex transpose of a matrix.

$$S = (y'' - Xh) * (y'' - Xh)^t \quad (10)$$

This equation can be minimized by taking its derivative w.r.t 'h' and equating it equal to zero. The final equation is given by:

$$h'' = (X^t X)^{-1} X^t y \quad (11)$$

which can be written as

$$\begin{aligned} h'' &= X^{-1} y \\ hls &= X^{-1} y \end{aligned}$$

This equation can be implemented on SISO as well as MIMO systems.

Minimum Mean Square Error (MMSE) Equalizer

The MMSE estimator minimizes the mean-square error.

If 'X' is transmitted over a channel 'h' such that

$$y = X h \quad (12)$$

Error is given as

$$e = y'' - y \quad (13)$$

Where, y'' is expected output.

$$\begin{aligned} \text{Mean Square Error} &= \text{mean}\{(y'' - y)^2\} \\ &= E \{(y'' - y)^2\} \end{aligned} \quad (14)$$

Where, 'E' is operator for expected value

Concept of expected value and correlation can be used to derive the equations for finding the channel response.

R_{gg} - auto covariance matrix of 'g'

R_{YY} - auto covariance matrix of 'Y'

R_{gY} - cross covariance matrix of 'g' and 'Y'

The estimated channel H_{mmse} can be found out by the equation

$$H_{mmse} = F * (R_{gY} * R_{YY}^{-1} * Y) \quad (15)$$

Where, F is a noise matrix

$$R_{gy} = R_{gg} * F' * X'$$

$$R_{YY} = X * F * R_{gg} * F' * X' + (\text{variance of noise}$$

* Identity Matrix)

The equation can be used for both SISO as well as MIMO systems.

IV. Simulation Results

In this section, the simulation results are shown in terms of mean square error with respect to variation in SNR for 2x2 MIMO systems. Results are plotted using BPSK, QAM and 8-QAM and compared for MMSE and LS equalization algorithms.

Figure 2, 3 and 4 shows two subplots corresponding to MMSE and LS equalization techniques. From the figures it is clear that for various methods like BPSK, QAM and 8-QAM, the LS estimator gives better results than MMSE estimator. For various values of SNR, values of mean square error are tabulated in table no 1 below.

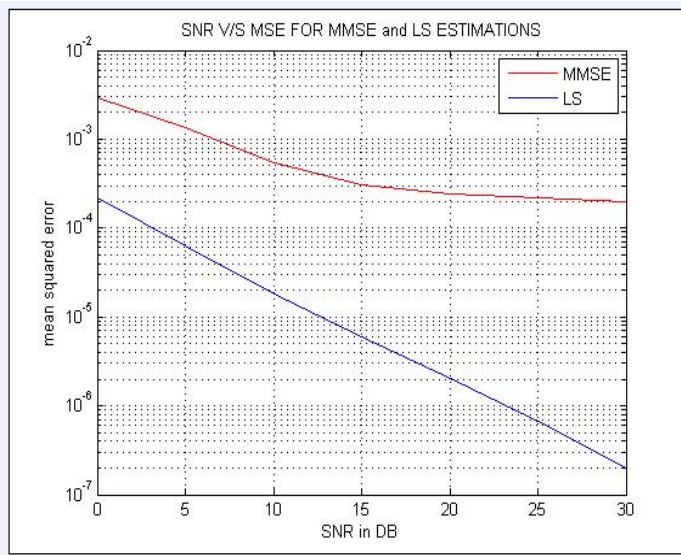

Figure 2 SNR VS MSE for BPSK

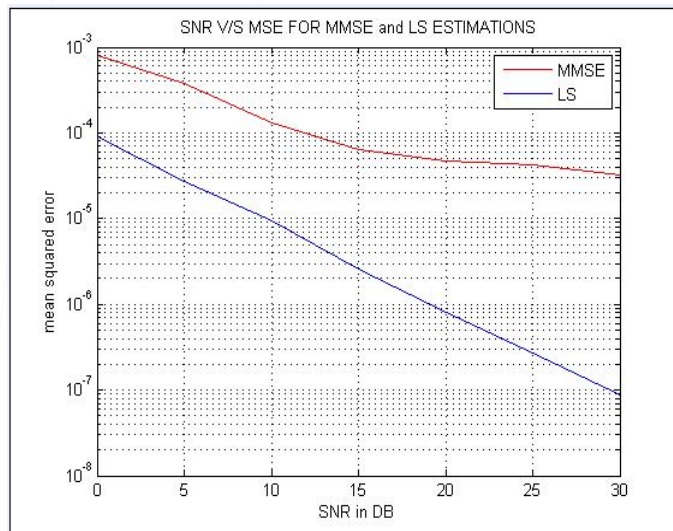

Figure 3 SNR vs MSE for QAM

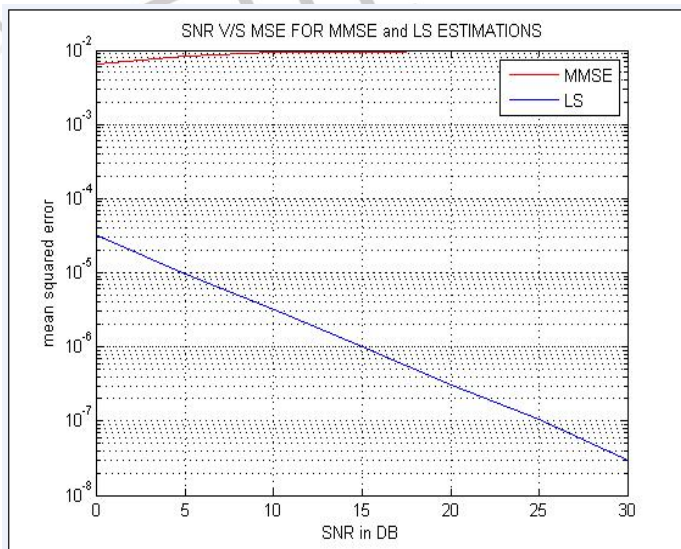

Figure 4 SNR vs MSE for 8-QAM

Table 1 Comparison of Mean Square Error for Various Modulation Techniques Considering LS and MMSE Algorithms

SNR (DB)	BPSK		QAM		8 QAM	
	LS	MMSE	LS	MMSE	LS	MMSE
00	$10^{-3.9}$	$10^{-2.8}$	10^{-4}	10^{-3}	$10^{-4.8}$	$10^{-2.1}$
10	$10^{-4.9}$	$10^{-3.6}$	10^{-5}	10^{-4}	$10^{-5.8}$	10^{-2}
20	$10^{-5.9}$	$10^{-3.8}$	10^{-4}	$10^{-4.5}$	$10^{-6.8}$	10^{-2}
30	$10^{-6.9}$	$10^{-3.9}$	10^{-7}	$10^{-4.9}$	$10^{-7.8}$	10^{-2}

V. CONCLUSION

In this paper, ISI due to multipath fading is effectively mitigated using LS and MMSE algorithms. These techniques are based on pilot aided block type training symbols. Mean square error analysis is done using these equalizers in Rayleigh selective frequency fading channel. LS equalizer has shown better results than MMSE equalizer.

In future, these algorithms can be implemented using different tap vectors to improve the results. Variation in modulation technique like QAM, 8 QAM and 16 QAM can also be implemented for improved results.

REFERENCES

- [1] Bhasker Gupta and Davinder S. Saini, "BER Performance Improvement in MIMO Systems Using Various Equalization Techniques", IEEE 2nd International Conference on Parallel, Distributed and Grid Computing, 2012.
- [2] K. Elangovan, "Comparative study on the Channel Estimation for OFDM system using LMS, NLMS and RLS Algorithms", in Proceedings of the International Conference on Pattern Recognition, Informatics and Medical Engineering, March 21-23, 2012.
- [3] T. C. Hewavithana, and D. M. Brookes, "Blind Adaptive Channel Equalization for OFDM Using the Cyclic Prefix Data", 2004.
- [4] Sajjad Ahmed Ghauri, Sheraz Alam, M. Farhan Sohail, Asad Ali, Faizan Saleem "Implementation of OFDM and Channel Estimation using LS and MMSE Estimators", International Journal of Computer and Electronics Research, Vol.2, No. 1, February 2013.
- [5] Navdeep Bansal, Sukhjeet Singh, Pardeep Kumar Jindal, "Channel Estimation Algorithms in OFDM, A Review", International Journal of Application or Innovation in Engineering & Management (IJAIEM), Vol. 2, Issue 6, June 2013.
- [6] Liu Kewen, Xing Ke, "Research of MMSE and LS channel estimation in OFDM systems", IEEE 2nd International Conference on Information Science and Engineering, Dec. 2010
- [7] Deepa T., Rajaguru S., Kumar R., "Performance analysis of SIMO and MIMO system with equalization", IEEE International Conference on Communication and Signal Processing, April. 2013.
- [8] Mydhili S. K., Rajeshwari A., "Equalization techniques in MIMO systems - An analysis", IEEE International Conference on Communication and Signal Processing, April. 2014.
- [9] Zhecheng An, Jun Wang, Su Huang, "MMSE-based equalization and ICI mitigation scheme for OFDM system over doubly selective channels", [IEEE International Symposium on Broadband Multimedia Systems and Broadcasting \(BMSB\)](#), June 2014.
- [10] Farhang A., Marchetti N., Doyle L.E. "Low complexity LS and MMSE based CFO compensation techniques for the uplink of OFDMA systems", IEEE International Conference on Communications, June 2013.