

Power Quality Improvement of Brushless DC motor Using Buck Converter

¹Dipak L. Parmar, ²Chirag K. Vibhakar, ³Firdaus F. Belim
¹P.G. Student Power System, ²Prof. & Hod, V.V.P. Engg. College, ³Assistant Professor
¹Electrical Engineering Department,
¹V.V.P Engg. College, Rajkot, India

Abstract- The Technique to improve the power quality of Brushless DC motor by power factor correction play an important role in the energy saving during Energy Conversion. In BLDC motor the ac-dc conversion of electric power is usually required; nevertheless, it causes poor power factor and many current harmonics in the input ac mains. In this Paper DC-DC Buck converter used as a single-stage power factor correction (PFC) converter for a brushless dc motor fed through a diode bridge rectifier (DBR) from a single-phase AC mains. The DC-DC converter shows conformity to international power quality standards with improved performance of BLDC Motor drive, such as reduction of AC main current harmonics, near unity power factor and reduction of speed and torque ripples. To operate the BLDC Motor a Three-phase voltage source inverter is used as an electronic commutator.

Index Terms - Brushless DC motor, Buck Converter, Voltage Source Inverter, PFC

I. INTRODUCTION

Brushless Direct Current (BLDC) Motors are one of the Motor Types Rapidly Gaining Popularity. BLDC Motors are used in Industries Such as Appliance, Automotive, Aerospace, Consumer, Medical, Industrial Automation equipment and instrumentation [4]. Brushes are not used in BLDC Motor for Commutation. BLDC Motors are electronically commutated motors.

There are Many Advantages of BLDC Motor Compared to Brushed DC Motor and Induction Motor [4].

- Better Speed versus Torque Characteristics
- High Dynamic Response
- High Efficiency
- Long Operating Life
- Noiseless Operation
- High Speed Ranges
- High Reliability
- Reduced Maintenance

They can Compete on Cost alone Due to Three Major Factor[5]:

- Advances in Magnet Technology
- Improvement in Motor Control Electronics
- Capital investment By BLDC Manufacturers

As a result, brushless DC motors are being used in a wide range of cost sensitive Applications.

II. CONSTRUCTION OF BLDC MOTOR

BLDC Motors are sometimes referred to as “Inside-Out Permanent Motors” Because Their Speed-Torque Curves are very similar to Those of PM Motors. However, BLDC Motors have their Magnets on the Rotating Part of the Motor instead of on Stationary part and Winding on Stationary part. Operation of a BLDC Motor is similar except that the Winding Phases are Switched On and Off Electronically by Means of Control Device. The Controlling is done by Hall Effect Sensors. The Rotor Assembly may be internal or external to the Stator in a DC Brushless Motor. The Combination of an Inner Permanent Magnet rotor and Outer Winding offers the Advantages of Lower Rotor inertia and more efficient Heat Dissipation than DC Brush type Construction[4].

Stator: The Stator of BLDC Motor Consists of Stacked Steel lamination With Winding Placed in the Slots. Stator slots Winding is arranged in a Delta Pattern (Δ) or Star Pattern (Y). High torque and low RPM given by Star Pattern and Delta Pattern gives Low Torque and Low RPM[5].

Rotor: The Rotor is made of Permanent Magnet and can vary from Two to Eight Pole pair with Alternate N (North) and S (South) poles. There should be Proper Magnetic Material to Make the Rotor[5].

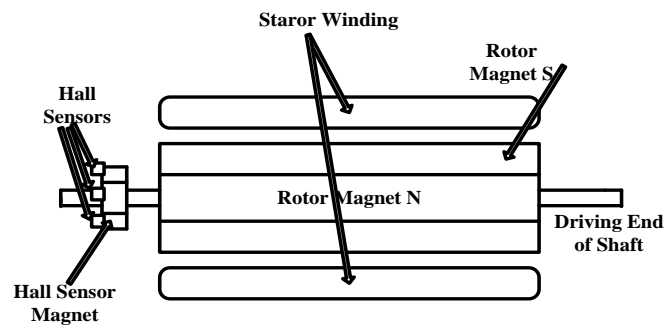

1.1 BLDC Motor[4]

Hall Sensors: Hall Sensor is a Device which is used to determine the Position of the Rotor of BLDC Motor. Mostly BLDC Motor Have Three Hall Sensors. Whenever the Rotor Magnetic poles pass near the Hall sensors then They Give high or Low Signals indicating N or S Pole pass Near the Hall Sensor. By using the Hall signal Combination the exact Sequence of Commutation can be Determined[5].

III. OPERATION OF BLDC MOTOR WITH INVERTER

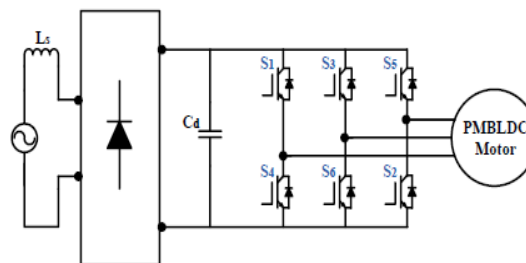

1.2 Single phase DBR fed VSI based BLDC Motor

BLDC Motor is basically electronic commutated motor so three phase inverter is requires at front end as shown in Figure 1.2 The commutation of semiconductor devices is depends on the rotor position sensed by Hall Sensors.

- **Pulse width Modulation**

The three phase, six step inverter has several advantages and limitations. The inverter control is simple and the switching loss is low because there are only six switching per cycle of fundamental frequency. Unfortunately, the lower order harmonics of the six step voltage will cause large distortion of current wave unless filtered by bulky and uneconomical low-pass filters. Besides, the voltage control by the line side rectifier has the usual disadvantages. PWM principle involves an inverter contains electronics switches, to control the output voltage as well as optimize the harmonics by performing the multiple switching within the inverter with a constant dc input voltage[6].

• **PWM Current Controller**

Pulse Width Modulation Current controllers are widely used. The switching frequency is usually kept constant in this controller. They are based in the principle of comparing a triangular carrier wave of desire switching frequency and are compared with error of the controlled signal. The error signal comes from the sum of the reference signal generated in the controller and the negative of the actual motor current[6].

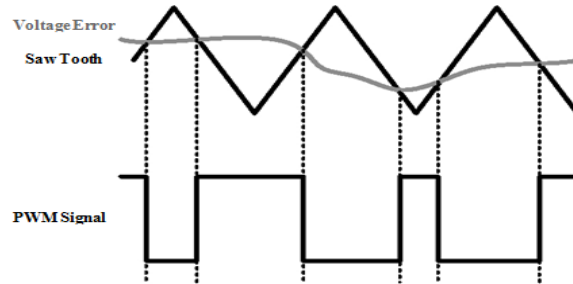

1.3 PWM Current Controller[6]

The comparison will result in a voltage control signal that goes to the gates of the voltage source inverter to generate the desire output. According to the error its control will respond. If the error command is greater than the triangle waveform, the inverter leg is held switched to the positive polarity (upper switch on)

The inverter leg is forced to switch at the frequency of the triangle wave and produces an output voltage proportional to the current error command. The nature of the controlled output current of a reproduction of the reference current with high frequency PWM ripple superimposed.

IV. PROBLEM IDENTIFICATION

A PMBLDCM has the developed torque proportional to its phase current and its back-emf is proportional to the speed. Therefore, a constant current in its stator windings with variable voltage across its terminals maintains constant torque in a PMBLDCM under variable speed operation. A speed control scheme is proposed which uses a reference voltage at DC link proportional to the desired speed of the PMBLDC motor. However, the control of VSI is only for electronic commutation based on the rotor position signals of the PMBLDC motor.

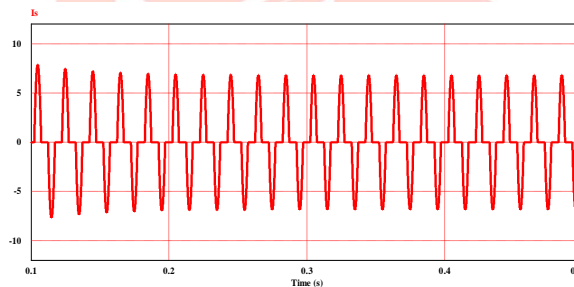

1.4 Current waveform at AC mains without PFC

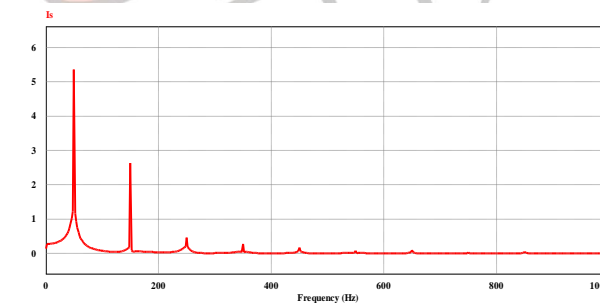

1.5 Harmonic Spectra for the PMBLDCM drive without PFC

The AC mains current waveform, as shown in Fig 1.4, is far from sinusoidal, because of the fact that the DBR does not draw any current from the AC network when the AC voltage is less than the DC link voltage, as the diodes are reverse biased during that period; however, it draws a peaky current when the AC voltage is higher than the DC link voltage. This results in pulsed input current waveform featuring a peak value higher than the peak of the fundamental input current, thereby, 62.53% total harmonic distortion (THD) in the input current and power factor (PF) of 0.84 at AC mains. The PMBLDC motor have to be operated from utility supply, therefore they should conform to the international Power Quality standards such as IEC 555-2, and IEC 61000-3-2. Total Harmonic Distortion is measured in PSIM using FFT analysis.

Table 1.1 Problem Simulation Result Data:

Supply Voltage(Vs)	230V
Supply Current(Is)	3.74A
Fundamental frequency	50Hz

(%)THD of I_s	62.53%
Power Factor	0.84

V. DC –DC CONVERTER

There are various dc-dc converter are used in power electronic device.

- **BUCK CONVERTER**
- BOOST CONVERTER
- BUCK-BOOST CONVERTER

• **Buck Converter:**

The buck or step-down converter which is shown in Figure 1.6 regulates the average DC output voltage at a level lower than the input voltage. This is accomplished through controlled switching where the DC input voltage is turned on and off periodically, resulting in a lower average output voltage.

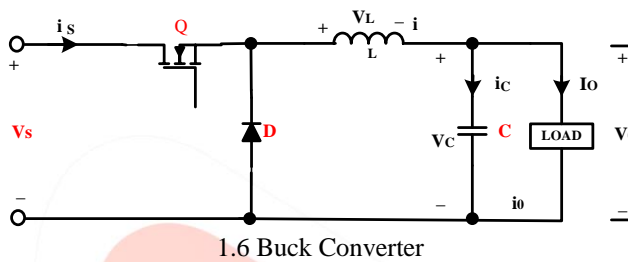

1.6 Buck Converter

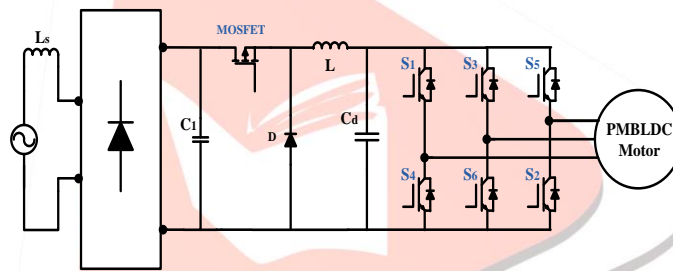

1.7 Buck Converter fed VSI based BLDC Motor

Figure 1.7 shows the Buck converter fed BLDC motor drive. It uses input and output filters to improve its performance in terms of THD of AC mains and ripples at DC output voltage. In this topology a conventional Diode Bridge Rectifier fed from single phase AC mains. Its output is given to a DC-DC converter and VSI is used to feed the BLDC motor.

VI. PERFORMANCE EVALUATION OF BLDC DRIVE

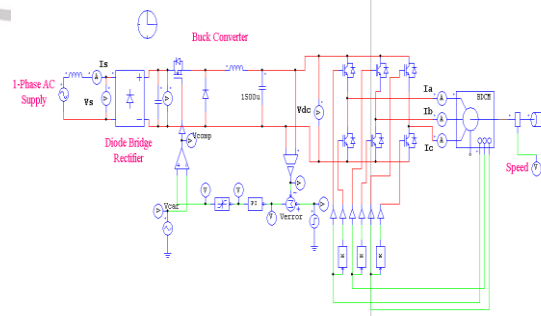

1.8 Simulation of Buck Converter fed VSI based BLDC Motor

- **Phase Current**

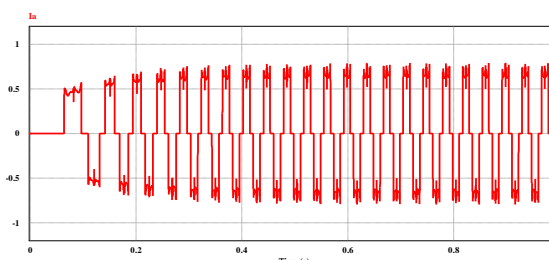

(a) Phase current **I_a**

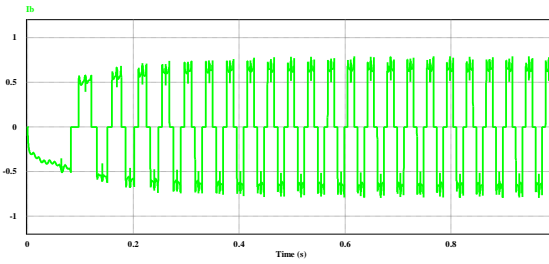

(b) Phase current **I_b**

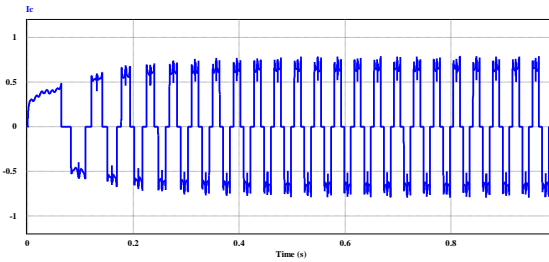

(c) Phase current **I_c**

• **FFT Analysis of Supply Current**

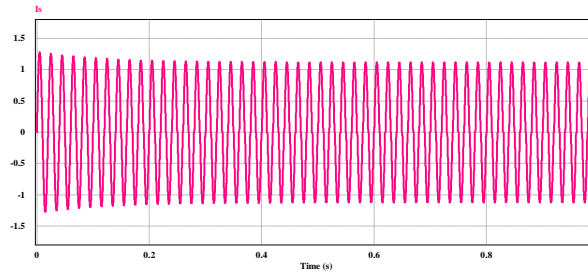

(a) Supply Current

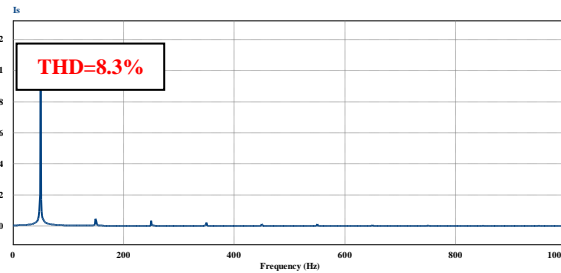

(b)THD of Supply Current

• **Supply Current and Supply Voltage**

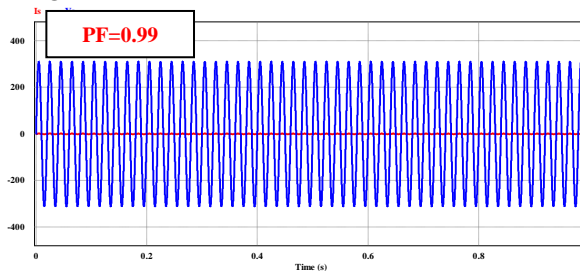

(a)Supply voltage & Current

• **Power Quality Parameter**

Supply Voltage(V _s)	230V
Supply Current(I _s)	0.8A
Fundamental frequency	50Hz

(%)THD of Is	8.3%
Power Factor	0.99

VII. CONCLUSION

The DC-DC Converters like buck Converter for brushless DC motor is analyzed in this Paper. The DC-DC Converter topologies for power quality improvement in Brushless DC Motor drives are design and their performance is simulated in PSIM. The speed of Brushless DC motor has been found proportional to the DC link voltage, thereby a smooth speed control is observed while controlling the DC link voltage. The result of simulation shows that total harmonic distortion in AC supply current is reduced and power factor is improved near unity with the help of Buck Converter as per International power quality standards.

REFERENCES

- [1]. Sanjeev Singh, Bhim Singh “A Voltage Controlled PFC Cuk converter based PMBLDCM Drive for Air-Conditioner” IEEE TRANSACTION ON INDUSTRY APPLICATION, VOL.48,NO.2,MARCH/APRIL 2012.
- [2]. J.Karthikeyan, Dr.R.Dhana Sekaran “DC-DC converter CSI fed BLDC motor for Defense Application” International Conference on Recent Advancements in Electrical, Electronics and Control Engineering, 2011.
- [3]. B. Singh, S. Singh “Single-phase power factor controller topologies for permanent magnet brushless DC motor drives” IET Power Electronics, Vol. 3, Iss. 2, pp. 147-175, 2009.
- [4]. Brushless DC (BLDC) Motor Fundamentals, **Author:** Padmaraja Yadmale, Microchip Technology Inc.
- [5]. Brushless DC Motor, **Author:** K.B. Shah
- [6]. Handbook, Industrial Electronics series, edited by TIMOTHY L.SKVARENINA, Purdue University West Lafayette, Indiana.

