

Web based remote monitoring, control and data acquisition load cell based cement packaging plant

¹Kukadiya Hina, ²Patel Ashish, ³Jayesh Parmar

¹PG Scholar Student, ²Asistant professor, ³Director of Shaktikrupa Automation

¹Instrumentation and Control, DDU, Nadiad, India.

Abstract— The modern IT society is based on internet access and many organizations and persons take advantages of the increased accessibility and flexibility that the internet provides for products. In this paper the data of cement packaging plant is getting from any location by accessing the Website. Also the automation of cement packaging plant is done by Programmable logic controller. The main aim of the paper is to design and fabricate an accurate packaging system using Programmable logic controller software and accurate weighing of cement bag. Programmable logic controller technology have been increasing rapidly and proving its role in automation beneficially. In addition to that, this system is able to decrease product time and increase the product rate as compared with traditional manual system.

IndexTerms— WEBSITE, Programmable logic controller (PLC), Human machine interface (HMI), Laboratory Virtual Instrument Engineering Work bench

I. INTRODUCTION

In this project the cement packaging is done by automation .Due to automation in cement packaging the operation will be safe and accurate as per our requirement. We get the online data acquisition of cement packaging by access website from anywhere. The data acquisition makes the secure by giving them password. The weight of cement bag is accurately controlled Programmable logic controller software (WECON Editor) & Human machine interface provides the visual representation of a control system and provides real time data acquisition. Virtual screen also provide for Graphical Representation.

II. WORKING PRINCIPLE AND BLOCK DIAGRAM

First, the bag need be applied manually to the filling spout and the filling process is started by a push button. Your material will firstly go to the hopper and then be filled into the bags via screw feeding parts. The filling flow is controlled by the linear actuator by changing its position (up or down) across shaft. When the bag is filled fully, the bag clamping device will automatically open and the bag will be conveyed to the sewing system for sealing. Manually bag placing > Automatic filling > Automatic weighing

The load cell is used to measure the weight of the object. A load cell is a nothing but transducer which is used to create an electrical signal as per weight on it. Weight controller is a load cell controller which is used to measure the accurate weight of the object. 3-phase AC motor is used for operate the screw shaft that's why the cement can be transmitted from hopper to bag. Contactor works as switch but here it is mainly use for safety purpose. Human machine interface is the interaction between the user and the machine at a given task.

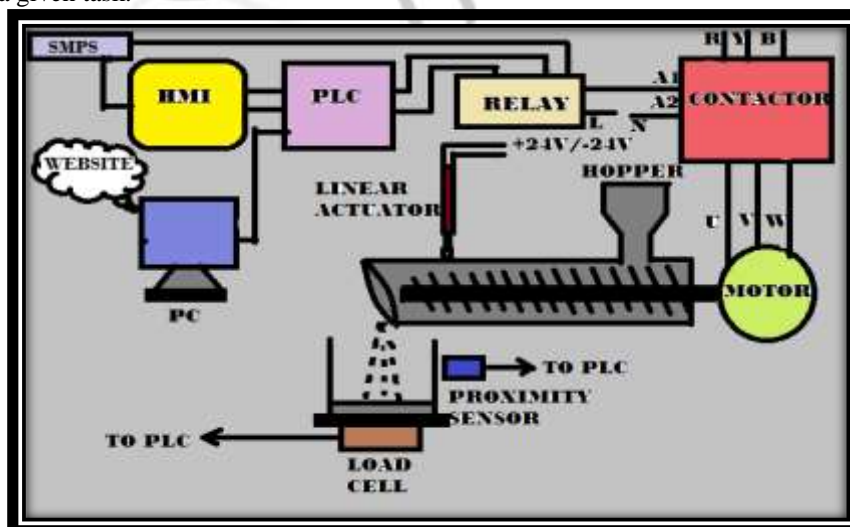

“Figure 1: Block Diagram”

III. WEB BASED DATA ACQUISITION

Software use for making website is visual basic studio 2010 version. Technology is dotnet technology. Language is C#. From labview HyperTerminal we get the data of cement packaging machine. By hosting this data to internet we get the cement packaging machine from anywhere if the world. But here local data acquisition making for getting data of cement packaging machine.

For getting the data of cement packaging machine user first have to register her/his detail into site. Then they have to must login.(By user Id & Password)

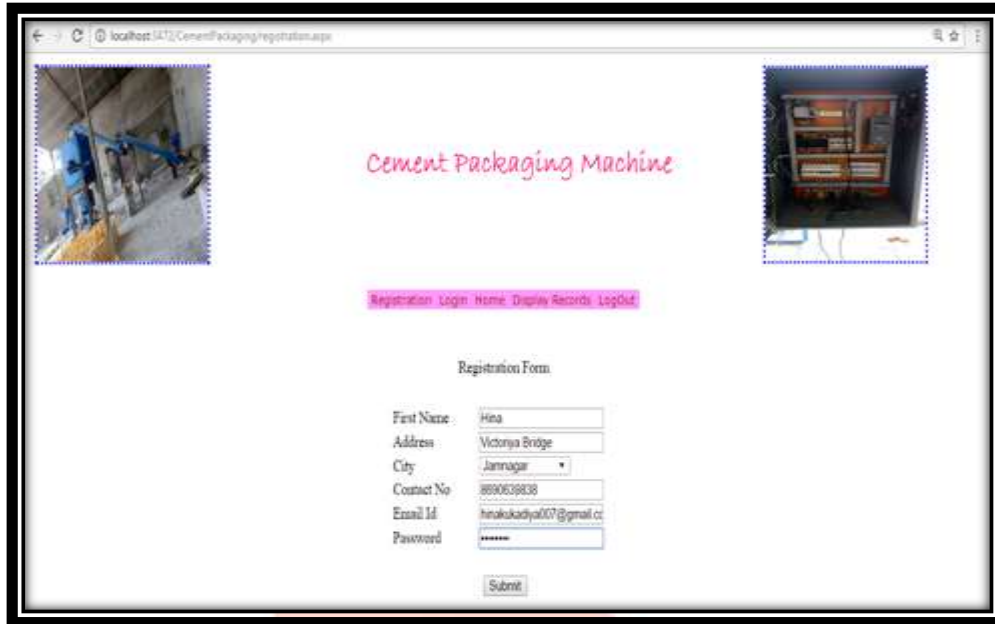

“Figure 2: Registration Form Window”

As they are logged in with correct user Id and Password they get the data of cement packaging machine. We also record the history of all data getting from site.



“Figure 3: Login Id window”



“Figure 4: Cement Packaging Bag Details Window”



“Figure 5: Record of Cement Packaging Machine”

IV. CONTROLLING AND HUMAN INTERFACE WITH MACHINE

Wecon plc is use for controlling the machine. Which consists of 8/6 - I/Os. Load or weight value is in kg which is send in RS-10 transmitter which give output in 0-10 v range. This signal given to plc’s ADC card which convert analog signal value in digital one. Finally actual load value is calculated in plc and compare with set value. If the actual value of cement bag is equal to the set value then motor is stop and linear actuator stroke is come upward side. Proximity sensor sense the availability of the bag as per that it gives signal to plc to start or stop the motor.

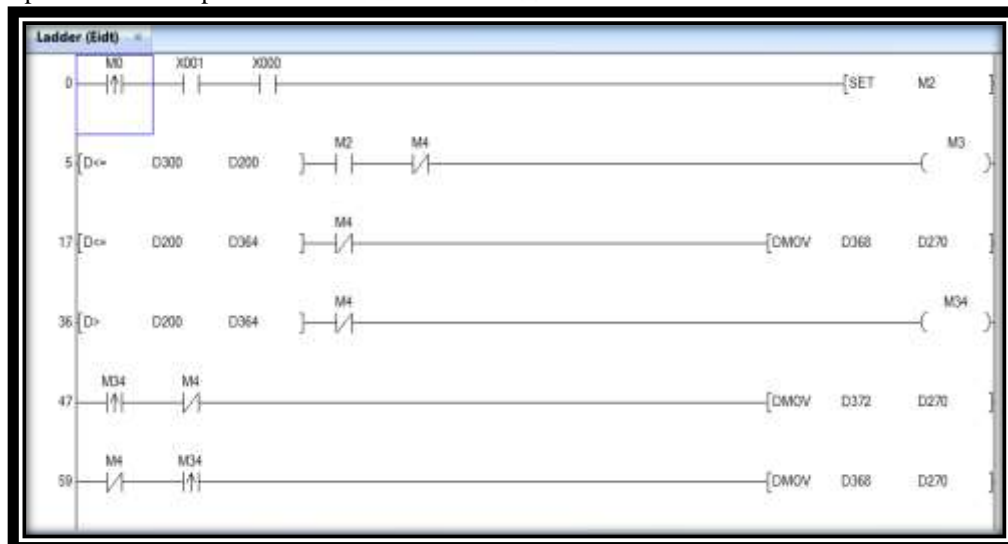

“Figure 6: Programming screen of PLC”

In main operating screen there are many value shown. Like the current load (Weight) value of cement bag, Total number of bags has been filled, How much batches done, also which no. is bag is filling also shown. Start and stop button for to command the machine run/stop. If machine is running that indication also show by green led. Other parameter like holding down, holding up, indicating by led shown below.



“Figure 7: Human Machine Interface Operating Screen”

Abbreviations and Acronyms

PLC- Programmable logic controller, HMI – Human Machine Interface, Labview- Laboratory Virtual Instrument Engineering Work bench, PC- Personal Computer, I/O- Input Output, ADC- Analog to Digital Converter

Units

Bag Weight in kg, Stroke of liner actuator in mm

Labview software is use for virtual representation of machine operation also for acquisition of machine data from labview hyper terminal. Simulation of load versus Time show in graph. As the bag is fill up by cement its load is indicating in the form of graph versus time. Means at what time the bag will be fill up. As an example 40kg cement packaging takes what time suppose it takes 30 sec which is indicating in virtual screen.

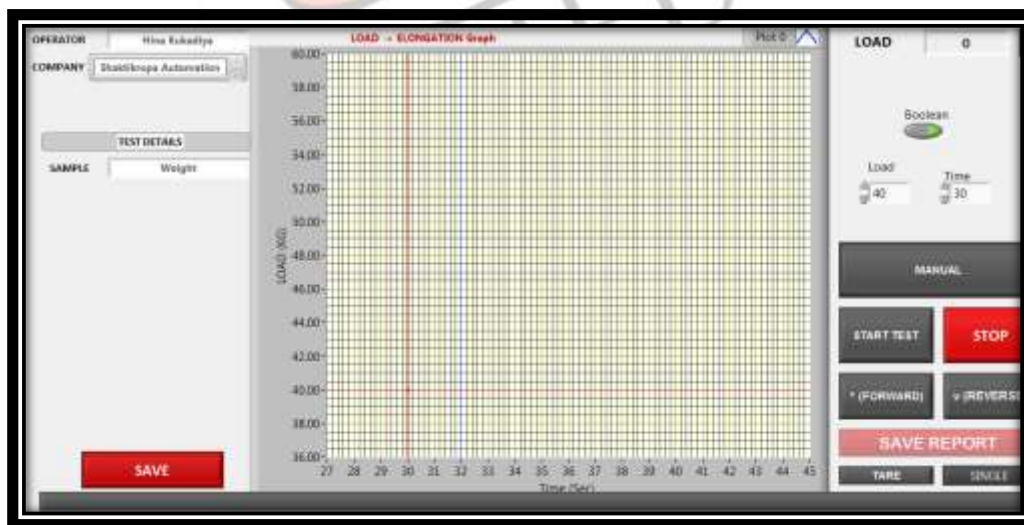

“Figure 8: Labview Screen”

V. BIOGRAPHIES



Hina S. Kukadiya has received her Bachelor of Engineering with Instrumentation & Control Engineering from Government Engineering College, Rajkot, Gujarat Technological University, Ahmedabad, Gujarat, India. Her areas of interests include Automation Systems, Industrial Process Control, Biomedical Instrumentation, Nano Technology.

E-Mail: hinakukadiya007@gmail.com



Prof. Ashish G. Patel received his Bachelor of Engineering with Instrumentation & Control Engineering from College Dharmsinh Desai University, Nadiad in 1999 and Master of Engineering with Instrumentation and Control Engineering from Dharmsinh Desai University, Nadiad in 2004. He has 4.5 year industrial experience and more than 11 year teaching experience. His area of interest in the various fields of instrumentation like Analytical Instrumentation (Electron Microscopy), Biomedical Instrumentation, Distributed control System, Robotics & Control systems, Automation field etc.

E Mail: ashishddit@gmail.com, ashishpatel.ic@ddu.ac.in



Jayesh Parmar received his Bachelor of Engineering with Instrumentation & Control Engineering from LD College of Engineering, Ahemdabad in 2011 and Master of Engineering with Instrumentation and Control Engineering from Dharmsinh Desai University, Nadiad in 2013. He has 2.5 year industrial experience. His area of interest in the various fields of instrumentation like automation based machinery, Plc and Hmi based system, programming in labview, Make control panels of electrical and automation based.

VI. ACKNOWLEDGMENT

I heartly thankful to Mr. Ashish G. Patel and Mr. Jayesh Parmar for give me guideline and support in my research work.

REFERENCES

- [1] D. Kanimozhi, B .Nantheni Devi & T. Manochandar **PLC Controlled Automatic Food Packaging Machine** from International Journal of Engineering Trends and Technology (IJETT) – Volume 30 Number 1 - December 2015
- [2] Prashant kumar¹, H M Mallaradhya² **Automatic Tablet Filler Using PLC** from International Journal for Research in Applied Science & Engineering Technology (IJRASET) Volume 3 Issue VIII, August 2015
- [3] Pardeep Kumar **Technological Development And Change In Cement Industry In India** from International Journal of Recent Scientific Research Vol. 6, Issue, 4, pp.3575-3583, April, 2015
- [4] M. R. Saraf, V. V. Ruiwale, V. V. Kulkarni and S. M. Kulkarni **Design and Development of Cost Effective Automatic Machine for Powder Packaging** from International Journal of Current Engineering and Technology Accepted 02 March 2016, Available online 15 March 2016, Special Issue-4 (March 2016)
- [5] Md. Ashaduzzaman, Farzana Mahbub **Understanding the Role of Packaging Elements on Buying Detergent Powder in Dhaka City: A study on Bangladesh** from Asian Journal of Business Research ISSN Volume 6 Issue 1 2016