

# Design and Fabrication of Cross Country Pipeline Cleaning Robot

<sup>1</sup>Abhijeet A. Carvalho, <sup>2</sup>Joel J Coalco, <sup>3</sup>Charleswin L. Dsouza, <sup>4</sup>Sanket S. Kini, <sup>5</sup>Parag V. Nikam  
<sup>1</sup>Bachelor of Engineering Student, <sup>2</sup> Bachelor of Engineering Student, <sup>3</sup> Bachelor of Engineering Student,  
<sup>4</sup> Bachelor of Engineering Student, <sup>5</sup>Assistant Professor  
<sup>1</sup>Department of Mechanical Engineering,  
<sup>1</sup>St.John College of Engineering and Management, Palghar(E), Palghar, India

**Abstract**— Cross country pipelines are basically pipelines outside the battery limit of storage plant. These are generally long distance pipeline covering various Roads, Rail, Rivers crossing sometimes also across the Sea. These pipelines are designed, fabricated and inspected as per Code API 5L. These pipelines are lined, with materials such as Rubber, PTFE, FRP etc., in order to protect the pipe material from any type of reactions and corrosion. Various types of fluids such as crude and refined petroleum fuels such as oil, natural gas and biofuels and other fluids such as sewage, slurry, and raw water are also transported through these pipelines. In order to make use of same pipeline for transporting different fluids, it is necessary to clean the pipe before next fluid is to be transported. Therefore there is a strong demand for a cleaning robot. These are Cleaning pig assembly is commercially available and used in Industry. The concept of this project is to build a low cost cleaning robot, which will perform multitasking along with the cleaning. This project is basically design to clean the pipe internally so different fluid can easily flow through it. The dimensions of the robot are adjustable depending upon the internal diameter of the pipe. The front three wheels are driven and the rear three wheels are driver. The Cleaners consists of Brush, Sponge, Scrubber and microfiber cloth are placed on main shaft which with the help of centrifugal rotation cleans the pipe internally powered by the motor. The layer depositions can be cleaned by cleaner material placed on cleaner plate, this cleaning material can be easily changed.

**Keywords** - API-American Petroleum Institute, PTFE-Poly Tetra Fluoro Ethylene, and FRP-Fiber reinforced plastic.

## I. INTRODUCTION

Cross Country Pipelines exist for the transport of crude and refined petroleum, fuels – such as oil, natural gas and biofuels – and other fluids including sewage, slurry, water, and beer. Cross Country Pipelines are useful for transporting water for drinking or irrigation over long distances when it needs to move over hills, or where canals or channels are poor choices due to considerations of evaporation, pollution, or environmental impact. Pneumatic tubes using compressed air can be used to transport solid capsules. Oil pipelines are made from steel or plastic tubes which are usually buried. The oil is moved through the pipelines by pump stations along the pipeline. Natural gas (and similar gaseous fuels) are lightly pressurized into liquids known as Natural Gas Liquids (NGLs). Natural gas pipelines are constructed of carbon steel. Hydrogen pipeline transport is the transportation of hydrogen through a pipe. District heating or tele-heating systems use a network of insulated pipes which transport heated water, pressurized hot water or sometimes steam to the customer.



Figure 01: Experimental Setup of pipe cleaning robot

The amount of manpower needed to move this oil is not that much. Cross Country Pipelines offer the most efficient mode of transporting this oil across a land mass. Even though these pipes are extremely cost effective there are some circumstances where this is not true and it is more logical to use another method. An example of this is how it is cheaper and more logical to use a ship to move the oil across the Atlantic Ocean than a pipeline

## II. PROBLEM FORMULATION AND METHODOLOGY

### 1. Problem Formulation

Transportation of fluids over wide distance is a necessity of the modern world for industrial purpose. This is accomplished by pipeline constructed nationwide called "Cross country pipelines". But for the change of fluid to be transported arises the problem, that different fluid required their own separate lines, which is an uneconomical and impractical process to undertake.

### 2. Methodology

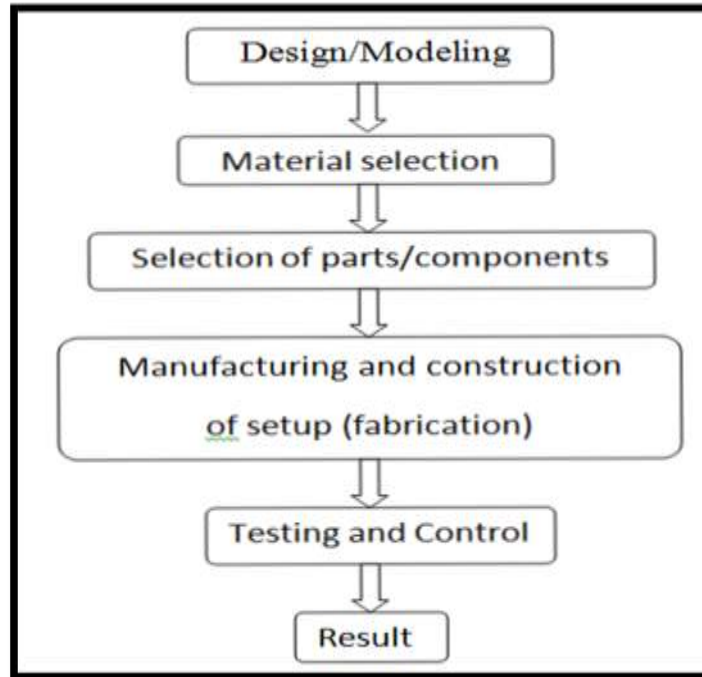

Figure 02: Fabrication Flow-chart

## III. MATERIALS AND METHODS

### 1. Modeling of Robot

The robot is designed and modeled in Solid Works software by designing each part of the robot and assembling them. First the shaft was modeled, then bearings were mounted on both sides of the shaft in the bearing housing. There are two bearing housings; each consists of three extended arms which supports the wheels. The cleaning bases were then attached to the shaft using nut bolts. Based on the dimension of the main shaft motor and wheels motors the supports of the motors were designed.

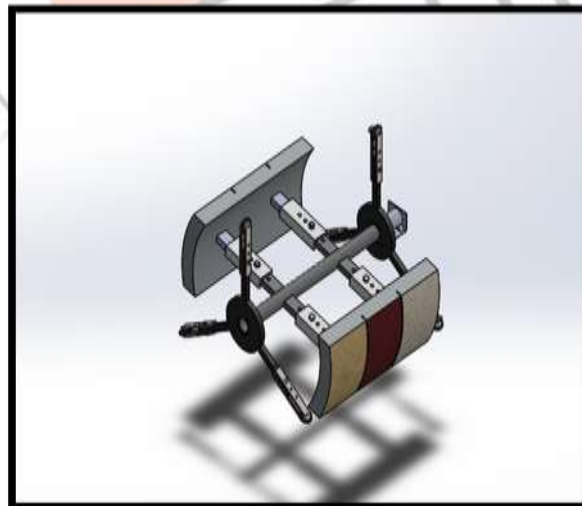

Figure 03: Modeling of Robot

### 2. Parts.

#### 1) Pipe-

The fabrication of the pipe a Mild Steel sheet of dimensions 1595 x 1500 mm is cut and then the sheet is rolled into a pipe of 22" diameter and length 1500mm. The rolled sheet is then welded along its length by argon welding process. Thus the pipe for demonstration of robot is ready.



Figure 04: Fabrication of the pipe

### 2) Cleaner Material Base

The cleaner material base is made by rolling small sheets of Mild Steel of 360mm x 250mm and thickness 2mm each, and welding the 1 inch square pipes to the rolled sheet. The size of the cleaning materials is easily adjustable according to the diameter of the pipe. It is variable from 18" to 22". The size is adjusted by loosening the nut bolts and moving the cleaners up or down in the slot provided on the main shaft.



Figure 05: Cleaner Material Base

### 3) Shaft

The shaft is designed to be hollow to reduce the weight of the entire assembly. The inner diameter of the shaft is 55mm and the outer diameter is 62mm. The material used for the shaft is Mild Steel as it is tough, ductile, it has good tensile strength. The shaft is made by working on a cylindrical rod on a lathe machine and welding the 1.5 inch square pipes to it. The square pipe has slots for the adjustment of the cleaners.



Figure 06: Shaft

**4) Bearing Housing**

It is made by welding three 1"x1" square pipes to the circular ring of inner diameter 42mm and outer diameter 60mm and thickness 25.4mm in which the bearings will be fixed. The material used for square pipes and circular ring is Mild Steel. The square pipes are of thickness 1.5mm.



Figure 07: Bearing Housing

**5) Frame**

First the shaft was manufactured, then two bearings were mounted on both sides of the shaft in the bearing housing. The each bearing housings consists of three extended arms which supports the wheels. The rear three wheels are directly mounted on their respective motor shafts and the front three are mounted on fixed shaft. The front three wheels are free to move were as the rear three are driven by motors. The cleaning bases were then attached to the shaft using nut bolts. Based on the dimension of the main shaft motor and wheels motors the supports of the motors were welded, at the required position.



Figure 08: Frame assembly

**IV. OBSERVATIONS AND RESULTS**

The testing was carried out by adding a layer of water of 10 mm for the first test, 15mm for the second test and 20mm for the third test at the bottom of lined pipe of O.D. 512mm and 1500mm long and applying a small layer about its circumference which is the condition while cleaning or maintenance period of the pipe. The results obtained are as tabulated below

Sr No	WATER		Efficiency
	Layer before cleaning	Layer after cleaning	
1	10mm	1mm	90 %
2	15mm	1mm	93.33%
3	20mm	2.5mm	87.5%

Table 01: Observation no 01

Another test was carried out by adding a layer of oil of 10 mm for the first test, 15mm for the second test and 20mm for the third test at the bottom of lined pipe of O.D. 512mm and 1500mm long and applying a small layer about its circumference which is the condition while cleaning or maintenance period of the pipe. The results obtained are as tabulated below.

Sr. no.	OIL		Efficiency
	Layer before cleaning	Layer after cleaning	

1	10mm	3mm	70%
2	15mm	3.5mm	76.66%
3	20mm	5mm	75%

Table 02: Observation no 02

EFFICIENCY (%)

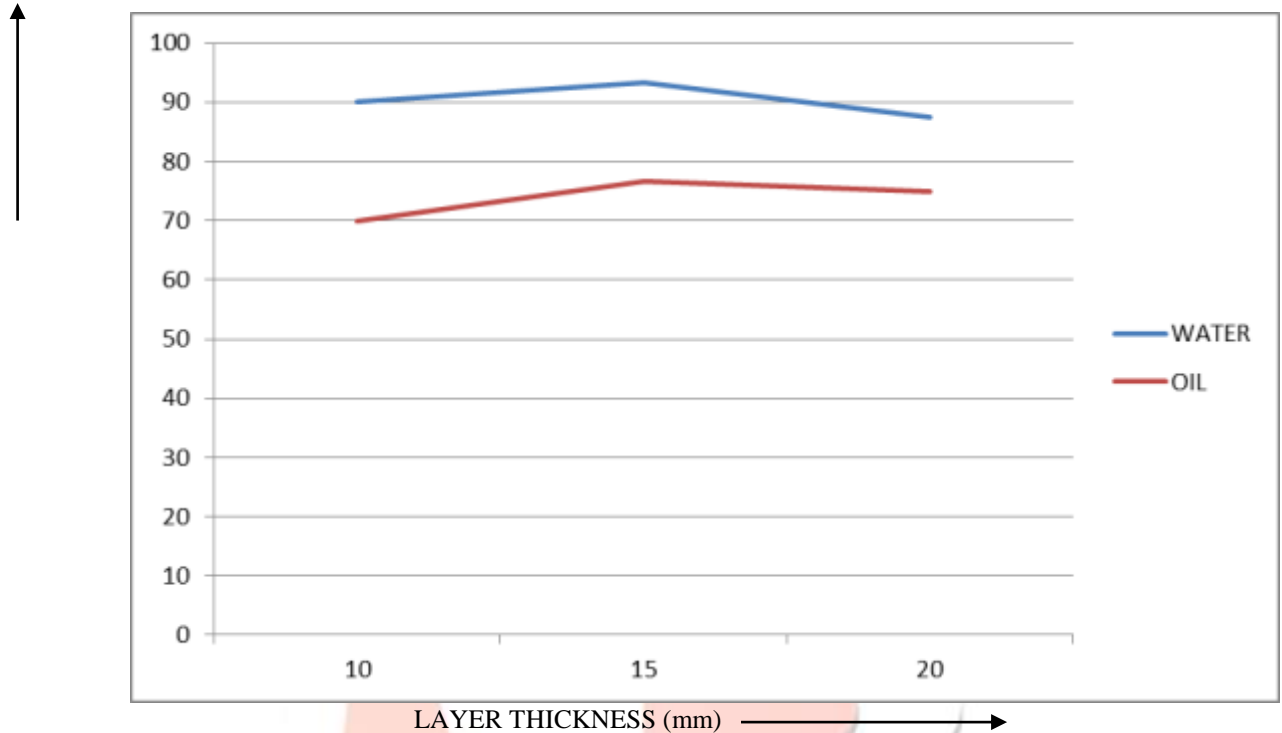

Graph 01: Results

## V. CONCLUSION

Cross country pipelines are basically used to avoid theft, leakage and contamination. As mostly preferred for the fluid which is transported across the country where chances of above affairs as well as cost of implementations are on higher side, pipe cleaning robot gives flexibility in terms of reusing or reutilization of pre commissioned pipeline (underground or above ground level). Also the cost for cleaning is comparatively less considering the fact the robot serves. Also this robot is preferred for pipelines which are internally lined, which eliminates the human efforts in terms of cleaning as well as inspection internally.

## VI. ACKNOWLEDGMENT

This work was supported by Department of Mechanical Engineering of St. John College of Engineering and Management, Vevoor, Palghar(E), Maharashtra. We also like to thank Mr. Austin Carvalho, Owner of Carvalho Engineering Works, Vasai (E) for allowing us to work on our project in their premises and providing us the required facilities.

## VII. REFERENCES

- 1) Ankit Nayak, S.K. Pradhan. "Design of a new in-pipe inspection robot" 12<sup>th</sup> Global Congress on Manufacturing and Management, GCMM 2014, PP.2081-2091.
- 2) Ana sakura zainal abiding "Development of track wheel for in pipe robot application" IEEE International Symposium on Robotics and Intelligent Sensors IRIS 2015, PP.506-511.
- 3) Sharol mohammadan "Development of track wheel for in pipe robot application" IEEE International Symposium on Robotics and Intelligent Sensors IRIS 2015, PP.500-505.
- 4) Nur shahida roslin "A Review: Hybrid locomotion of in pipe inspection robot". International Symposium on Robotics and Intelligent Sensors IRIS 2012, pp.1456-1462.
- 5) khairul salleh mohammed sahari. "Development of low cost small sized in pipe robot". IEEE International Symposium on Robotics and Intelligent Sensors IRIS 2012, PP.1469-1475.
- 6) Mohd zafri baharuddin. "Robot for boiler head inspection" IEEE International Symposium on Robotics and Intelligent Sensors IRIS 2012, PP.1483-1489
- 7) Soma shekhar s. hire math, "Development of a autonomous sewage cleaning robot" International conference on Design and Manufacturing, IConDM 2013, PP. 1464-1473.