

# Biometric Based Electronic Voting Machine

<sup>1</sup>Rajkumar Mistri, <sup>2</sup>Anamika, <sup>3</sup>Sushmita Kumari

<sup>1</sup>Assistant Professor, <sup>2,3</sup>B.Tech Scholar,

<sup>1,2,3</sup>Dept. of ECE, RTC Institute of Technology, Ranchi

**Abstract**— The objective of voting is to allow voters to exercise their right to express their choices regarding specific issues, pieces of legislation, citizen initiatives, and/or to choose their government and political representatives. But, now-a-days it has become very usual for some forces to indulge in rigging which may eventually lead to a result contrary to the actual verdict given by the people. In order to provide inexpensive solutions to the above, this project will be implemented with biometric system i.e. finger print scanning. This is used to ensure the security to avoid fake, repeated voting etc. It also enhances the accuracy and speed of the process. The system uses thumb impression for voter identification as we know that the thumb impression of every human being has a unique pattern. Thus it would have an edge over the present day voting systems. The purpose of such system is to ensure that the voting rights are accessed only by a legitimate user and no one else. In this, creation of a database consisting of the thumb impressions of all the eligible voters in a constituency is done as a pre-poll procedure. During elections, the thumb impression of a voter is entered as input to the system. This is then compared with the available records in the database. If the particular pattern matches with anyone in the available record, access to cast a vote is granted. But in case the pattern doesn't match with the records of the database or in case of repetition, access to cast a vote is denied or the vote gets rejected. The result is instantaneous and counting is done. The overall cost for conducting elections gets reduced and so does the maintenance cost of the systems. The recording and counting of votes will be faster, more accurate and with less man power.

**Index Terms**—: Fingerprint scanning, Database, Thumb impression, Arduino, Microcontroller, TFT LCD, Buzzer, Fingerprint scanner, Matrix, Membrane Keypad

## I. INTRODUCTION

In every country Election is a basic process of democracy which allows people to show their opinions by selecting their candidate. India is spending huge money to improve our whole voting system to provide a better government to citizens. In India, voting system should be honest, translucent and fully secure for the better democracy. The current system is used to less transparency because there could be chances of cheating at the voting time. Authentication of Voters, Security of the voting process, protecting voted data these are the main challenges of current Election voting. That's why it is necessary to generate a secure election voting system. In this paper, we have proposed an election voting system which is based on the fingerprint of voter which is saved as unique identification number in a database. At present, the voter is required to show his voter ID card whenever he goes to the booth to cast vote which is often a time consuming method because the person needs to check the voter ID card with the list he has, make sure it as an authorized card and then enable the person to poll his vote. But in the finger print based voting machine the individuals need not to carry his ID which contains his entire details. The voter places his Finger on the fingerprint module. This information is passed to the controlling unit for the verification and the controller reads DATA from the reader and compares this data with the already existing data. If the data matches with the already stored information, the person is allowed to poll his vote. If not, a message is displayed on LCD and therefore the person isn't allowed to poll his vote. The polling mechanism is carried out manually using the. LCD is employed to display the related messages.

## II. OBJECTIVE

The main objective of this project is to design a reliable and secure voting system. This system would allow only the legitimate users to cast their vote by verifying their fingerprint as an identity proof. If the fingerprint matches with the details stored in database then the user is allowed to cast vote otherwise restricted if fingerprint does not match or vote is being repeated. This system avoids rigging of votes and saves time and human effort.

## III. EXISTING SYSTEM

The existing Electronic Voting Machine (EVM) were devised and designed by Election Commission of India in collaboration with Bharat Electronics Limited (BEL), Bangalore and Electronics Corporation of India Limited (ECIL), Hyderabad. An EVM consists of two units, i) Control Unit and ii) Balloting Unit

The two units are joined by a five-meter cable. The Control Unit is with the Presiding Officer or a Polling Officer and the Balloting Unit is placed inside the voting compartment. This voting system has following process or phases:

1. Verification: In the verification process, voter verifies by showing his/her voter ID card, this step is for public and verified by the governing officer. At the end of verification process, governing officer allow voter to cast his / her vote.
2. Voting: The voting process takes place in a protected booth where voter cannot be seen by any person. The voter cast vote on EVM machine.

3. Vote counting: At the end of voting, the governing officer collects all EVM machine and submit to the counting center. After that all the members of the election commission nominated by election commission of India, count the votes and the results are then announced.

There are several issues in the existing system, they are as follows:

1. Illegal voting (Rigging): Electoral fraud, election manipulation, or vote rigging is illegal interference with the process of an election, whether by increasing the vote share of the favored candidate, depressing the vote share of the rival candidates, or both. One candidate casts the votes of all or few members in the electoral list illegally. This is done externally at the time of voting.
2. Results: Counting of votes after the election is over is a manual process that takes too much time and human effort.

#### IV. PROPOSED SYSTEM

Our proposed system consist Arduino Mega, LCD display unit, Data Storage unit, Finger Print Module, Keypad Matrix & Buzzer. Initially LCD Display unit showing five options to start the process. These are 1 : Enrollment, 2 : Voting, 3 : Deleting All voting Records, 4 : Deleting All enrollment Records & 5 : Results. So in our proposed model firstly we have to enroll the voters or we can link the database to its adhaar database and then we can start the voting by choosing option 2 for it. Our proposed system block diagram is in fig.1.

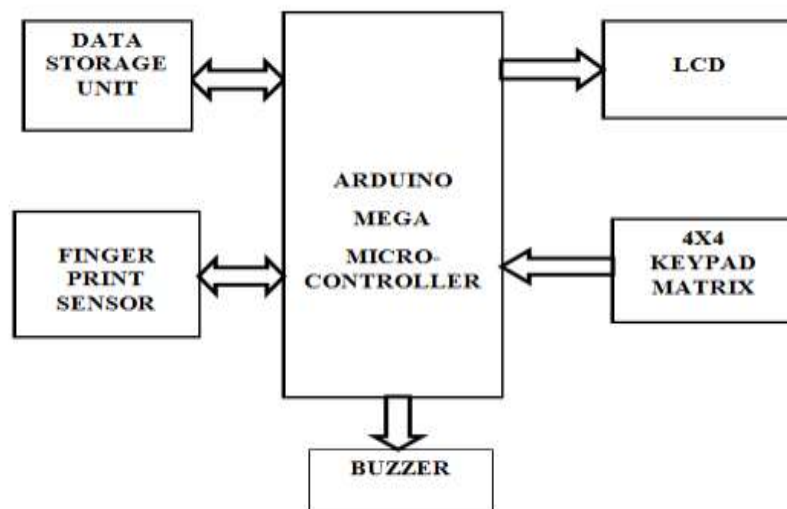

Fig.1 Proposed system block diagram

#### V. MODULE / COMPONENT DESCRIPTION

##### Fingerprint sensor

Fingerprint processing includes two parts: fingerprint enrollment and fingerprint verification. The GT-511C3 fingerprint scanner is a small embedded module that consists of an optical sensor mounted on a small circuit board. The optical sensor scans a fingerprint and the microcontroller and software provides the modules functionality which automatically processes the scanned fingerprint. When enrolling, user needs to press the finger three times. The system will process the three time finger images, generate a template of the finger based on processing results and store the template. During verification, user press the finger through optical sensor and system will generate a template of the finger and compare it with templates of the finger library. The verification can be 1:1 or 1:N. For 1:1 verification, system will compare the live finger with specific template designated in the Module; for 1: N matching, or searching, system will search the whole finger library for the matching finger. In both circumstances, system will return the verification result, success or failure. Fig.2 show the fingerprint module[6].



Fig.2 Fingerprint module

##### LCD

A liquid-crystal display (LCD) is a flat-panel display or other electronically modulated optical device that uses the light-modulating properties of liquid crystals. Liquid crystals do not emit light directly, instead using a backlight or reflector to produce images in color or monochrome[1].

A Thin-film-transistor liquid-crystal display (TFT LCD) is a variant of a liquid-crystal display (LCD) that uses thin-film-transistor (TFT) technology to improve image qualities such as addressability and contrast. A TFT LCD is an active matrix LCD. Arduino 2.4" TFT LCD Touch shield is an Arduino UNO/ Mega compatible multicolored TFT display with touch-screen and SD card socket[3]. It is available in an Arduino shield compatible pin out for attachment. The TFT driver is based on S6D112 with 8bit data and 4bit control interface[4].



Fig.3 LCD display unit

### Arduino Mega

The Arduino Mega 2560 is a microcontroller board based on the ATmega2560. It has 54 digital input/output pins (of which 14 can be used as PWM outputs), 16 analog inputs, 4 UARTs (hardware serial ports), a 16 MHz crystal oscillator, a USB connection, a power jack, an ICSP header, and a reset button[5]. It contains everything needed to support the microcontroller; simply connect it to a computer with a USB cable or power it with a AC-to-DC adapter or battery to get started. More details of arduino mega is described in table.1. & Fig.4. Show the arduino mega microcontroller unit.

Table.1 details of arduino mega microcontroller

PARAMETER	VALUE
Microcontroller AT mega	2560
Operating Voltage	5V
Input Voltage (recommended)	7-12V
Input Voltage (limits)	6-20V
Digital I/O Pins	54 (of which 14 provide PWM output)
Analog Input Pins	16
DC Current per I/O Pin	40 mA
DC Current for 3.3V Pin	50 mA
Flash Memory	256 KB (of which 8 KB used by boot loader)
SRAM	8 KB
EEPROM	4 KB
Clock Speed	16MHZ



Fig.4 arduino mega (atmega 2560) microcontroller unit

### Keypad matrix

A matrix keypad circuit is a design used in most computer keyboards in which the key switches are connected by a grid of wires, similar to a diode matrix. Here we have used a 16-button keypad that provides a useful human interface component for the microcontroller project. Matrix keypad uses a combination of four rows and four columns to provide button states to the host device, typically a microcontroller. Underneath each key is a pushbutton, with one end connected to one row, and the other end connected to one column[7]. In order for the microcontroller to determine which button is pressed, it first needs to pull each of

the four columns (pins 1-4) either low or high one at a time, and then poll the states of the four rows (pins 5-8). Depending on the states of the columns, the microcontroller can tell which button is pressed. 4x4 membrane keypad is shown in fig.5.



Fig.5 4x4 Matrix membrane keypad

### Buzzer

A buzzer is an audio signaling device, which may be mechanical, electromechanical, or piezoelectric. A buzzer is a small yet efficient component to add sound features to our system[2]. It is very small and compact 2-pin structure. This is a simple buzzer which when powered will make a continuous Beeeeeeppp.... sound. Buzzer is used for audible alerts when vote has been casted or any finger is detected wrong.



Fig.6 buzzer

All the module & components finally assemble together & microcontroller code for this was developed finally & then finally we have reach to our goal of this project. Real hardware of our proposed system is shown in fig.7

In coding part we have used following header file

(a) #include <Adafruit\_GFX.h> (b) #include <UTFTGLUE.h> (c)#include "FPS\_GT511C3.h" (d) #include "SoftwareSerial.h"  
(e) #include <EEPROM.h> (f)#include <Keypad.h> and (g) #include <SD.h>

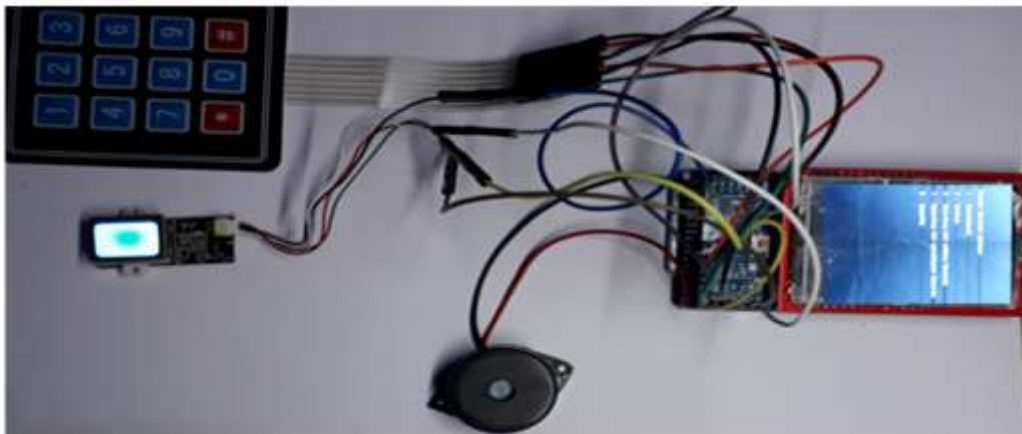

Fig.7 final hardware of our proposed system

### VI. CONCLUSION /FUTURE SCOPE

This project can be used for voting since it overcame all the drawbacks of ordinary voting machine and also provided additional security. Its main advantage is that since fingerprint of every person is unique and hence this system completely reduces the chances of invalid votes. This concludes that Biometric based Electronic Voting Machine will be useful:

(a) In avoiding rigging (b) In reducing time consumption (c)To keep the voter's information more secured (d) Iris or retina scanning can be included to make the security of the system much higher. (e) Face detection technology can be added for further security and to also help in the verification of person with disabilities. (f) GSM module can be used for casting votes through mobile so that voters far away from their constituency on the day of election can also cast their votes. (g) Audio output can be introduced to make it user friendly for unlettered voters.

### VII. ACKNOWLEDGMENT

We are highly obliged to our college "RTC Institute of Technology, Ranchi" that provided a healthy environment to move us to accomplish our goals. We would like to express our sincere gratitude to Prof. Rajkumar Mistri our guide and head of department

of Electronics & Communication Engineering for his guidance and support, which contributed to the successful completion of this project.

**REFERENCES**

- [1] [http://www.bioelectronix.com/what\\_is\\_biometrics.html](http://www.bioelectronix.com/what_is_biometrics.html)
- [2] <https://components101.com/buzzer-pinout-working-datasheet>
- [3] [https://en.wikipedia.org/wiki/Liquid-crystal\\_display](https://en.wikipedia.org/wiki/Liquid-crystal_display)
- [4] [https://en.wikipedia.org/wiki/Thin-film-transistor\\_liquid-crystal\\_display](https://en.wikipedia.org/wiki/Thin-film-transistor_liquid-crystal_display)
- [5] [https://www.tutorialspoint.com/arduino/arduino\\_board\\_description.htm](https://www.tutorialspoint.com/arduino/arduino_board_description.htm)
- [6] <https://www.androidauthority.com/how-fingerprint-scanners-work-670934/>
- [7] <http://wilsonhurd.com/images/pdfs/MembraneSwitchesDesignGuidelines.pdf>

