

Analysis of SEPIC Converter

¹Trivedi Bhavin, ²Bhavesh Patel, ³Jay Desai, ⁴Kamlesh Sonwane

¹⁻³Assistant Professor, ⁴Lab Assistant

Department of Electrical Engineering, GDEC College, Navsari-396406

Abstract - In modern era different portable electronic equipment is beneficial from a power converter which is having high efficiency with a wide input and output voltage ranges with a compact size. But conventional power converter can't able to maintain a wide operation range with high Efficiency, specially when up-and-down voltage is required. This characteristics can be obtained in a single ended primary inductor converter (SEPIC). The single-ended primary-inductor converter (SEPIC) is a type of DC/DC converter which allows voltage at its output to be greater than, less than, or equal to than at its input voltage. The output of the SEPIC is controlled by the duty cycle of the control transistor/IGBT/MOSFET. This Paper goes into detail of simulation of open loop & closed loop control for the SEPIC converter in MATLAB & results is analysed.

Key Words - SEPIC Converter, PID Controller, DC-DC Converter, MATLAB

INRODUCTION

The single-ended primary-inductor converter (SEPIC) is type of DC-DC converter allowing voltage at its output to be greater than, less than, or equal to that at its input. The output voltage of the SEPIC converter is controlled by controlling the duty cycle of transistor or IGBT OR MOSFET. A SEPIC is a boost converter followed by a buck-boost converter, it is similar to buck-boost converter, but has advantages of having the output has the same voltage polarity as the input, a coupling capacitor transfer energy from the input to the output. During turn on time diode is reverse biased due negative polarity of coupling capacitor and L2 is charged and L1 is charged through source and coupling capacitor is discharged. During turn off of switch L1 charged coupling capacitor and L2 transfers its energy to output and diode is forward biased in this case.

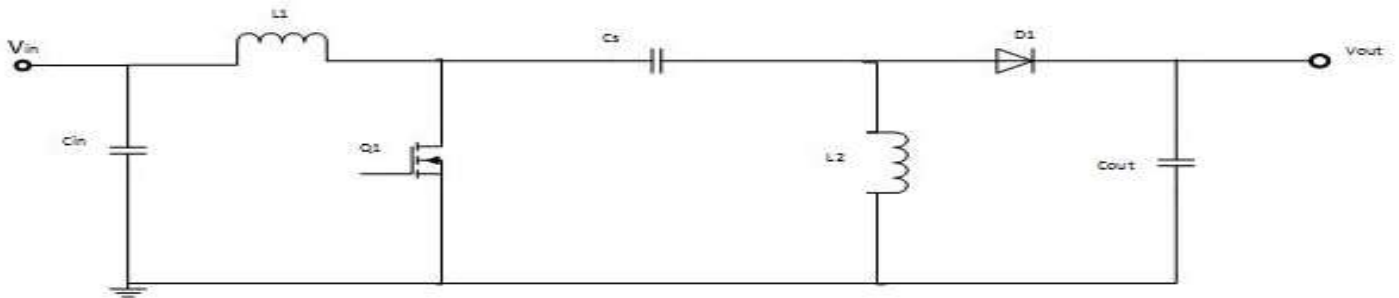

Figure 1.1 SEPIC Technology

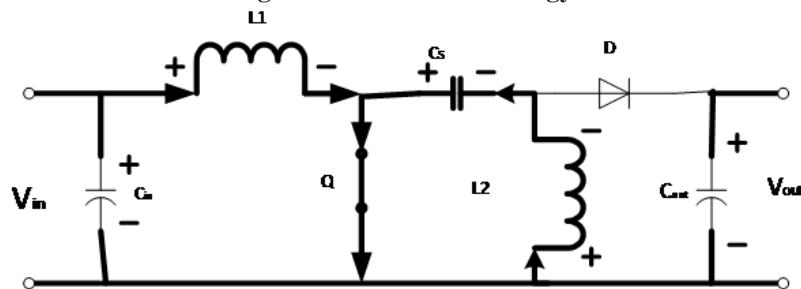

Figure 1.2 During On Time

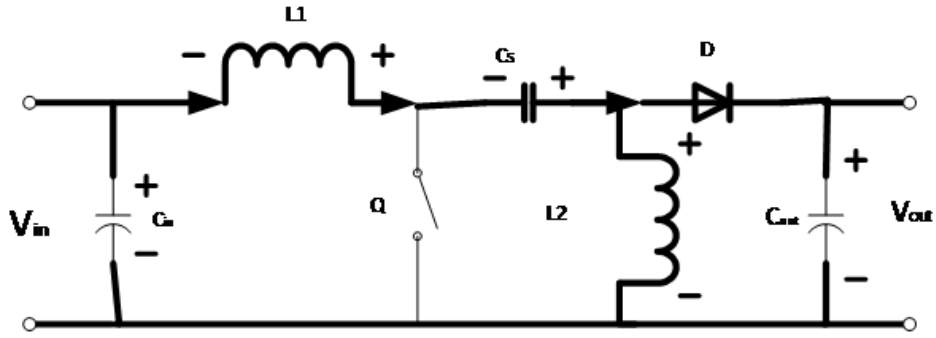

Figure 1.3 During off Time

1.2 Block Diagram

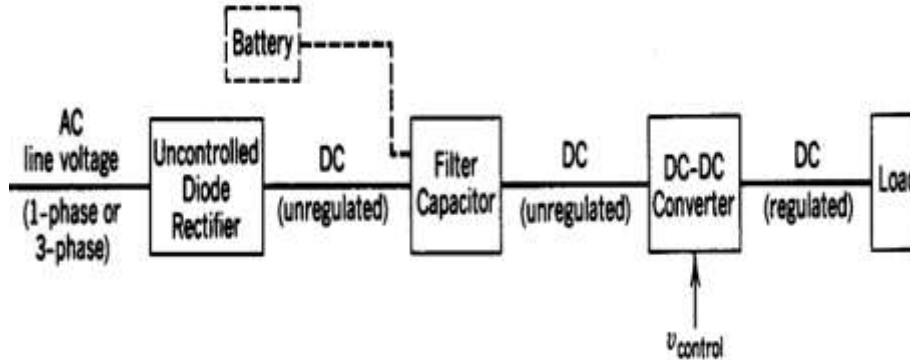

Figure 1.4 Block Diagram

As shown in block diagram we can regulate output dc voltage by changing duty cycle. Normally we have a.c. input voltage then we converting that a.c. to unregulated dc by uncontrolled rectifier then that unregulated dc is given to dc-dc converter which is SEPIC converter in our case which regulated dc output voltage. Filter capacitor is used to reduce ripple current.

Calculation

Duty cycle consideration

For a SEPIC converter operating in a continuous conduction mode , the duty cycle is given by.

$$D = \frac{V_{OUT} + V_D}{V_{IN} + V_{OUT} + V_D}$$

Inductor Selection

- The ripple current flowing in equal value inductors L1 and L2 is given by:

$$\Delta I_L = I_{IN} \times 40\% = I_{OUT} \times \frac{V_{OUT}}{V_{IN(min)}} \times 40\%$$

The value of L1 & L2 is calculated by:

$$L1 = L2 = L = \frac{V_{IN(min)}}{\Delta I_L \times f_{sw}} \times D_{max}$$

Power MOSFET Selection

- The peak voltage of switch is equal to Vin + Vout. The peak current is given by:

$$I_{Q1(peak)} = I_{L1(peak)} + I_{L2(peak)}$$

The RMS current through the switch is given by:

$$I_{Q1(rms)} = I_{OUT} \sqrt{\frac{(V_{OUT} + V_{IN(min)} + V_D) \times (V_{OUT} + V_D)}{V_{IN(min)}^2}}$$

Output Diode Selection

- The minimum peak reverse voltage the diode must withstand is:

$$V_{RD1} = V_{IN (max)} + V_{OUT (max)}$$

SEPIC Coupling Capacitor Selection

- The selection of SEPIC capacitor, Cs, depends on the RMS current, which is given by:

$$I_{Cs (rms)} = I_{OUT} \times \sqrt{\frac{V_{OUT} + V_D}{V_{IN (min)}}}$$

The peak-to-peak ripples voltage on Cs:

$$\Delta V_{Cs} = \frac{I_{OUT} \times D_{max}}{Cs \times f_{sw}}$$

Output Capacitor Selection

- The RMS current in the output capacitor is:

$$I_{Cout (rms)} = I_{OUT} \times \sqrt{\frac{V_{OUT} + V_D}{V_{IN (min)}}}$$

Open loop

(For Minimum Value)

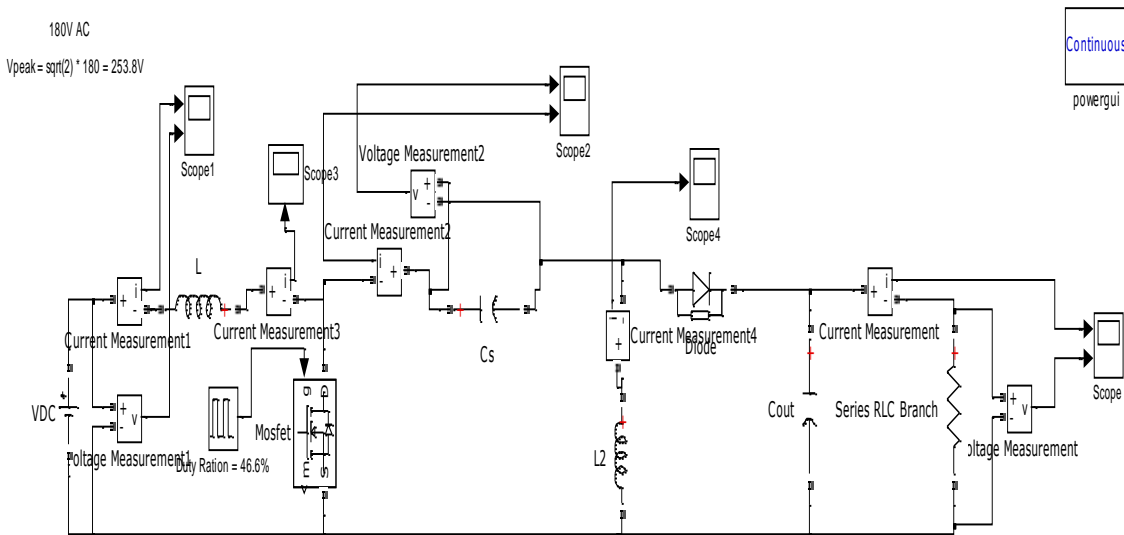

Input voltage	Duty ratio (%)	Output voltage
253.8 V	46.6	220 V

Output Waveform of Current & Voltage

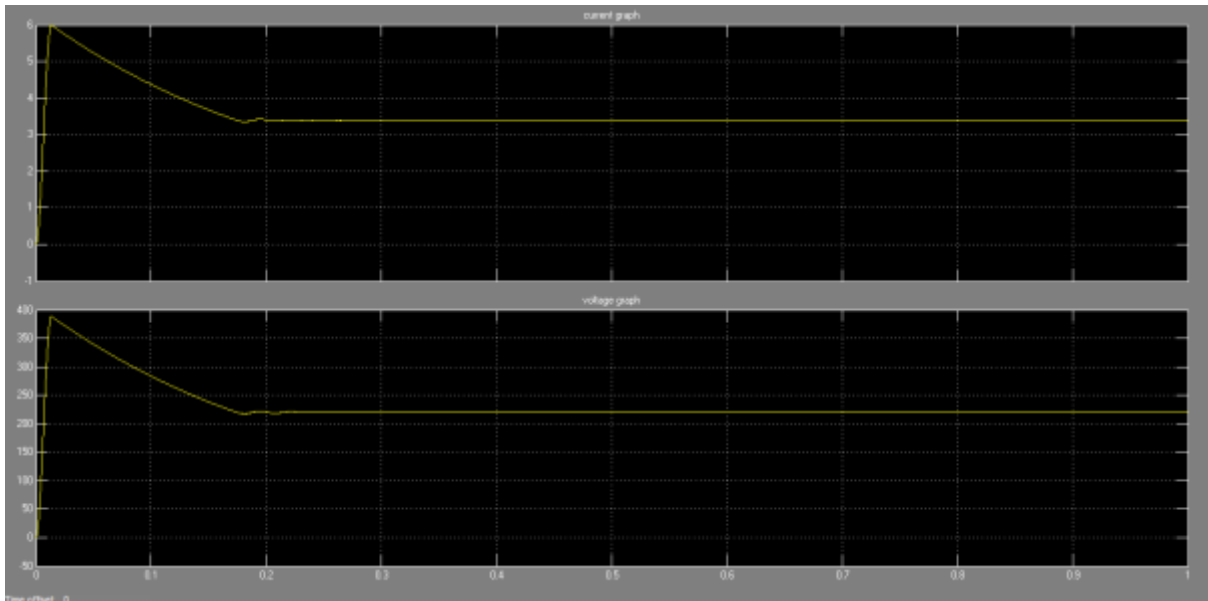

Waveform of inductor (L1) and capacitor (Cs)

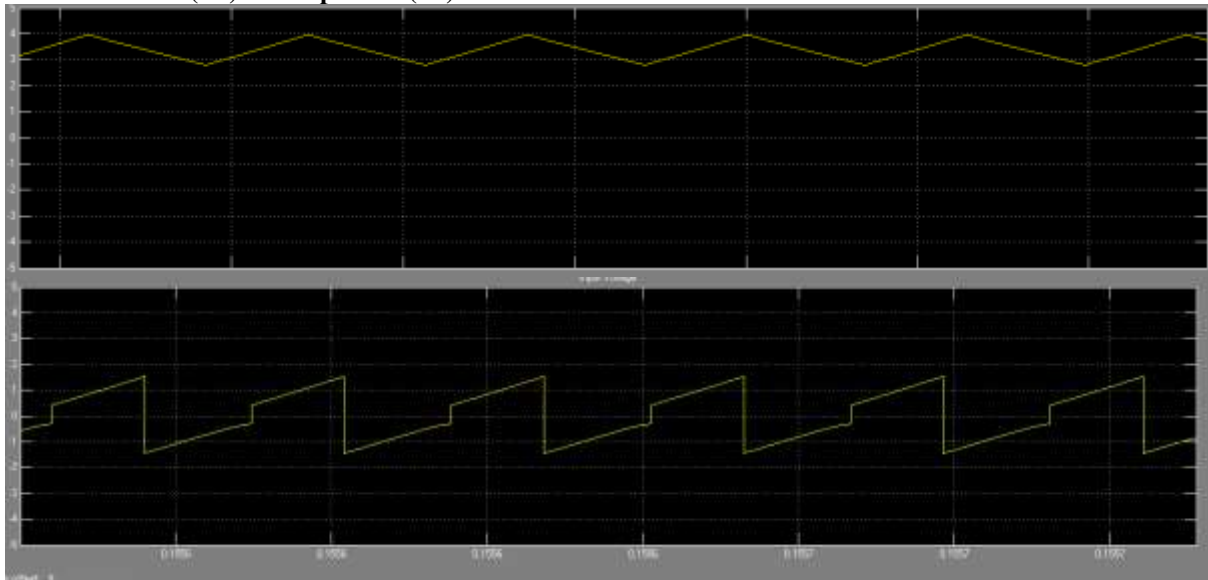
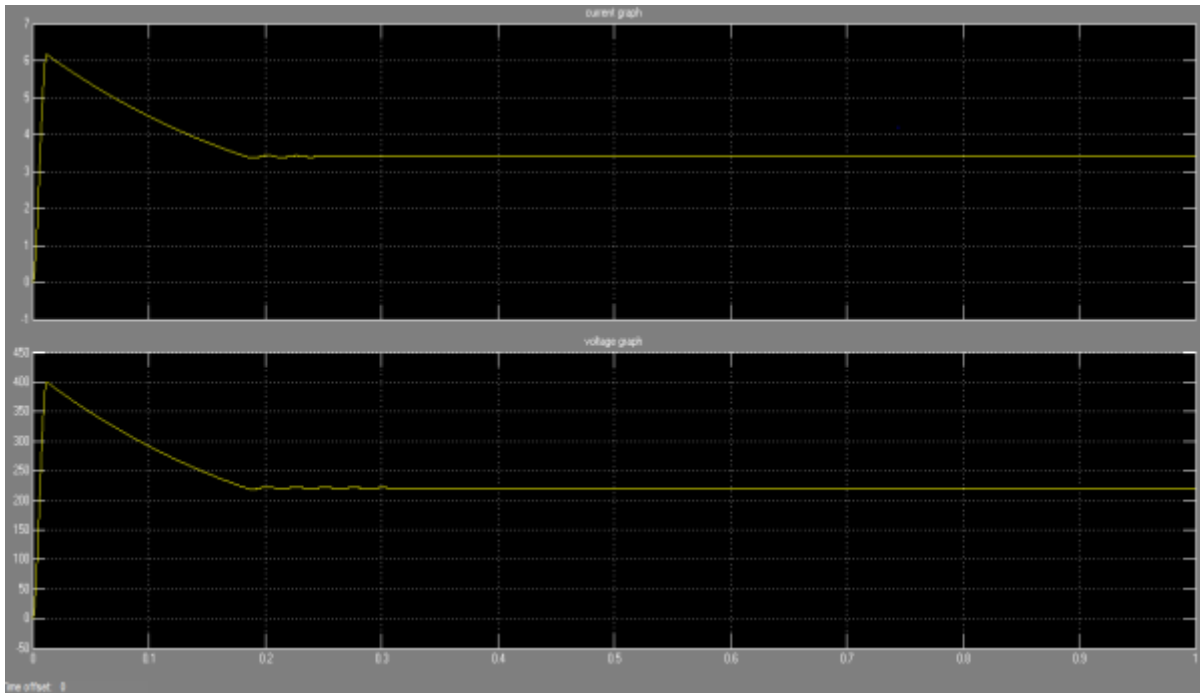

Table 4.2 SEPIC Converter (For Maximum Value)

Input voltage	Duty ratio (%)	Output voltage
325 V	40.6	220 V

Output waveform of Voltage & Current



Closed Loop

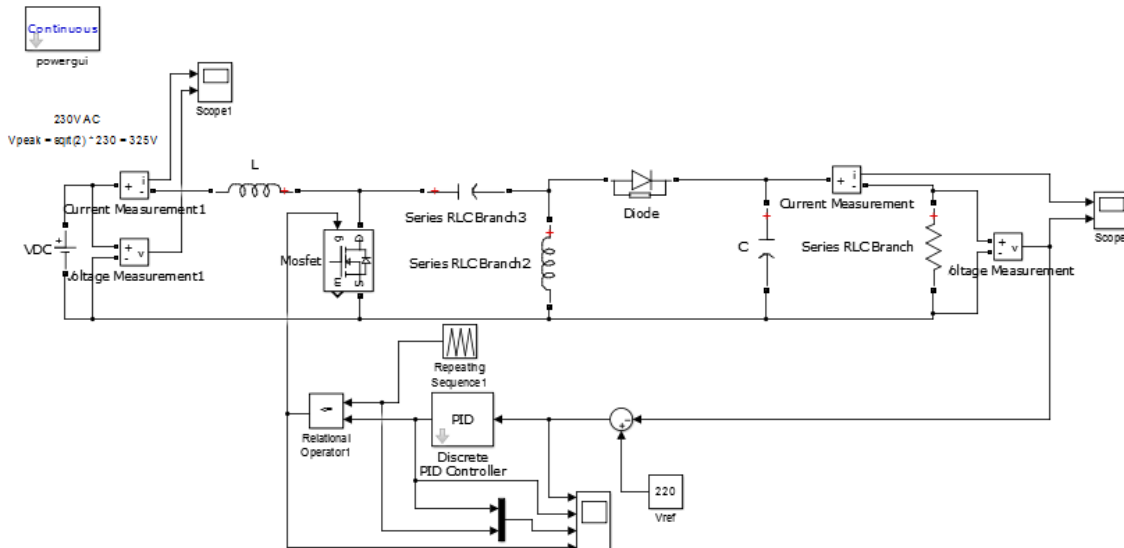

Figure 4.3 Closed Loop Control

Input voltage	Output voltage
325 V	220 V
100 V	220 V

In closed loop control we get more accurate result then open loop control. You can change your reference input and by proper tuning of PID controller you get accurate result as per your reference value, switching frequency is taken 39 KHz. Resistance is taken as load which has value of 61.11 ohm value of L1, L2,coupling capacitor, filter capacitor is calculate by using equation as shown.

Conclusion

The single-ended primary-inductor converter (SEPIC) has the ability to operate from an input voltage that is greater or less than the regulated output voltage. Aside from being able to function as both a buck and boost, the SEPIC design also has minimal active components, a simple controller, and clamped switching waveforms which provide low noise operation. Simulation results of closed loop control show that we can control dc output voltage as per our requirement and it changes by controlling duty cycle. In future, hardware of SEPIC converter will be implemented for speed control of dc motor.

REFERENCE

- [1] Yi-Ping Hsieh, Lung-Sheng Yang, TsorngJuu Liang, and Jiann-Fuh Chen, "A Novel High Step-Up DC-DC Converter for a Micro grid System," IEEE Trans. on Power Electron., vol. 26, no. 4, pp.1127-1136, April 2011.
- [2] Wei Gu , Dongbing Zhang, "Designing a SEPIC Converter", National Semiconductor Application Note 1484 , april 30 2008.
- [3] Power Electronics & its essentials by L.Ummanand.

- [4] Venkatanarayanan, S. and M. Saravanan, 2014. Proportional-integral Control for SEPIC Converter, Research Jnl. of Applied Sciences, Engineering and Technology, 8(5): 623-629.
- [5] Anbukumar Kavitha and Govindarajan Uma, 2010 Control of Chaos in SEPIC DC-DC Converter, Int. Journal of Control, Automation and Systems, 8(6): 1320-1329
- [6] Falin, Jeff. "Designing DC/DC converters based on SEPIC topology" 2008, Texas Instruments. December 2013

