

# Reduction Of Primary Re-Circulation Loss Zones For Expanded Flows

<sup>1</sup>Katturoju Ashokachary, <sup>2</sup>K.Narendra reddy, <sup>3</sup>Rajarao.V

<sup>1</sup>Assistant professor, <sup>2</sup>Assistant professor, <sup>3</sup>Assistant professor

<sup>1</sup>Department of Mechanical Engineering, Vidya Jyothi Institute of Technology, Hyderabad, India.

**Abstract**— Reduction in recirculation zone size in suddenly expanded geometries is one of the major issues to deal with. After the flow encounters the sudden expansion geometry like flow over rear side of any automobile, acquires many complex features like separation, re-circulation, attachment and reverse flow. These flow phenomena effect the performance of the automobile on the mileage basis. In the present study, flow over such geometries with blowing and suction scenario is studied for different  $L_{max}/L_{min}$  models, namely 3, 4 and 5. For  $L_{max}/L_{min} = 5$ , it is found that the re-circulation and loss zones are more. Further, the configuration of  $L_{max}/L_{min} = 5$  is subjected to different operating conditions like blowing and suction. For further improvement, blowing is done at different heads of pressure, like 200 mm and 300 mm of water. With suction, flow scenario is completely changed and attachment point is observed at the base of the model itself. Results thus identify the improved flow structure that can be useful to different applications like power generation in wind or gas turbines.

## I. INTRODUCTION

Flow past obstacles like steps is an interesting problem with wide range of applications. Flow over steps plays a dominant role in many practical situations. Most of the sequences involving flow past over various structures regard for the analysis of characteristics such as flow pattern, pressure distribution at various points etc. In order to meet the requirements of the working environment with accuracy and efficiency, most of these obstacles are comprised of cubical or cylindrical geometries. Moreover, since fossil fuels are getting depleted, it is necessary to increase the efficiency of existing power generation devices like gas turbines and internal combustion engines. Since internal combustion engines depend more on fossil fuels, gas turbines seem to be viable option and are more used in decentralized power generation. In order to get qualitative or quantitative information on them, we need to use flow visualization technique and understand the flow losses. Even, in a wind turbine, which is treated as a better alternative energy source, wind flow should be without any vortex or re-circulation region and impinge on the blades for more torque of the rotor. With the depleting fuel sources and increasing pollution levels, we must build up new concepts to increase the power generation abilities with less flow losses and thus improved performance from the system or component. Such flow over objects are not only applicable in power generation, but in other areas too.

Because of the growing importance, the researchers are showing much interest in those areas involving flow over such objects. Out of the geometries involving cubical structures, flow past steps has been proved as an interesting problem with wide range of practical applications. Though there is large amount of data both experimental and theoretical available in the literature, they are applicable mostly for high-speed flows. Only limited information is available for the case of low subsonic flow past steps. Even the available information was confined to only steps with faired entrance. The subsonic flow past the steps is an important area which needs further investigation. Main reason to study flow over stepped pattern is that it is being used most frequently than any of the other models. Though every application may not be an exact replica of the pattern, there may be slight modifications, which have their own specific considerations. For example, the most real time application is the body shape of any automobile (cars). A closer view at its shape gives an idea that it has been derived from the stepped pattern. The body shape of a car combines both forward facing ward facing steps. However, for drag reduction and practical utility point of view, various combinations of step patterns have to be studied thoroughly. Change in flow velocity due to change in the geometry of a pipe system sets up eddies in the flow, which do not follow a straight path to the center. It follows a spiraling and whirling path, called vortex. Outside of the vortex, flow moves slowly and near the center, it is more rapid. If the cross-section of a pipe with fluid flowing through it is abruptly enlarged at certain place, fluid emerging from the smaller pipe is unable to follow the sudden deviation of the boundary. Then the streamlines take a typical diverging pattern. This creates pockets of turbulent eddies in the corners, resulting in the dissipation of mechanical energy into intermolecular energy and the fluid flows against an adverse pressure gradient. The upstream pressure  $p_1$  is lower than the downstream pressure  $p_2$  since the upstream velocity,  $v_1$  is higher than the downstream velocity,  $v_2$  as a consequence of continuity. The fluid particles near the wall due to their low kinetic energy cannot overcome them adverse pressure hill in the direction of flow and hence follow reverse path under the favorable pressure gradient. This creates a zone of re-circulating flow with turbulent eddies near the wall of larger tube at the abrupt change of cross-section, resulting in a loss of total mechanical energy. After the flow encountering the sudden expansion, it separates from the wall and gets attached to the wall far away from the vertical wall. After the flow attaches to the wall, it moves towards the face of the model because of the presence of low pressure at the vertical wall. This re-circulated flow rejoins with the free stream flow and moves downstream. As the flow moves over a wall, loss in pressure takes place due to friction and after sudden expansion, velocity decreases and pressure increases. Due to their

low kinetic energy fluid particles near the wall cannot overcome the adverse pressure hill in the direction of flow and hence follow up the reverse path under the favorable pressure gradient as shown in Fig. 1.

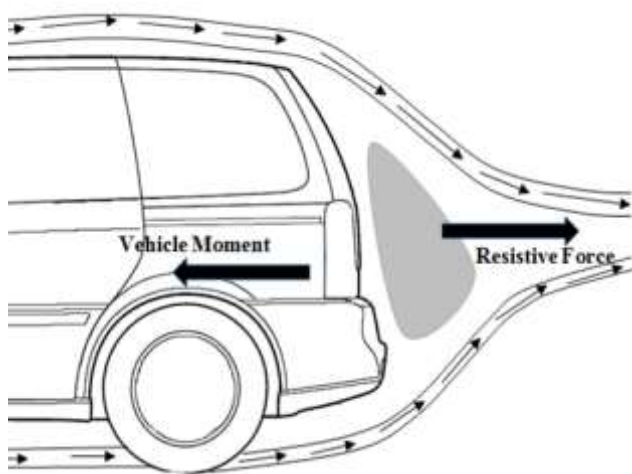
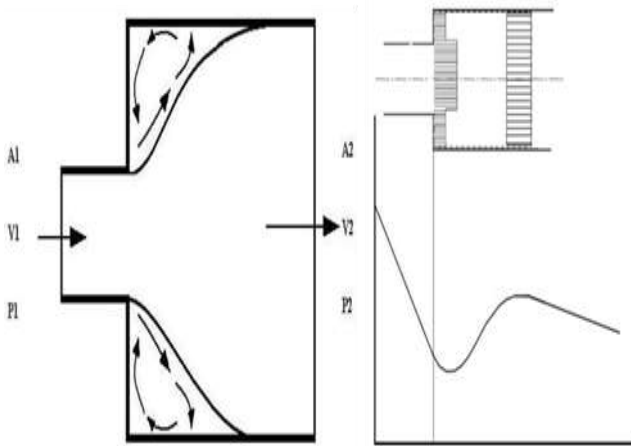

Figure 1 Representation of pressure variation across the sudden expansion geometry.

Figure 2. Flow over rear side of car

## II PROBLEMS WITH EXPANSION GEOMETRIES

In this section, previous works related to the studies on expansion geometries are presented. Earlier, Pak et al. [1] conducted flow visualization studies across the sudden expansion in a circular pipe. Patterns of reattachment regimes in both laminar and turbulent regions for different Reynolds numbers were analyzed. After a decade, Dales et al. [2] studied asymmetry in the turbulent flow of a visco-elastic liquid through an axi-symmetric sudden expansion. Conclusion drawn is that the asymmetry is purely a physical feature of such flow and not the product of upstream or downstream flow conditions derived from the flow facility or the result of geometrical imperfections in the axi-symmetric sudden expansion. Layek et al. [3] studied two-dimensional laminar flow of an incompressible Newtonian fluid in a symmetric sudden expanded channel with moderate expansion ratio. When the Reynolds number is relatively low, flow and the re-circulating regions at the two channel walls are symmetric. With the increase of Reynolds number, flow remains two-dimensional, but asymmetry of the flow occurs and additional recirculation zones appear along the channel walls. Dağtekin and Ünsal [4] conducted numerical analysis of axi-symmetric and planar sudden expansion flows for laminar regime. In this study, Navier - Stokes equations were solved numerically for axi-symmetric and planar sudden expansion flows. In the same year, Kaushik et al. [5] performed CFD simulation to investigate core annular flow through sudden contraction and expansion. Detailed study was performed to generate the profiles of velocity, pressure and volume fraction over a wide range of oil and water velocities for an abrupt expansion and contraction. Asymmetric nature of velocity across the radial plane is observed in both the cases. Tsai et al. [6] were involved in both computational and experimental investigations into the flow of a Newtonian fluid through a sudden expansion micro channel consisting of a rectangular block. It was found that both Reynolds number and aspect ratio have significant impact on the sequence of vortex growth, downstream of the expansion channel. Recently, laminar flow of inelastic non-Newtonian fluids, obeying the power-law model, through a planar sudden expansion with a 1:3 expansion ratio is investigated numerically using a finite volume method by Dhinakaran et al. [7]. Shear-thinning, Newtonian and shear-thickening fluids are analyzed, with emphasis on the flow pattern and bifurcation phenomenon occurring at high Reynolds number laminar flows. The effect of generalized Reynolds number, based on power-law index and the inflow channel height on the main vortex characteristics and Couette correction are examined in detail. Again, Bae and Kim. [8]

numerically investigated about the turbulent flow in axi-symmetric sudden expansion geometry with a chamfered edge. It was only a computational study, carried out for different chamfer lengths, angles and expansion ratios. In this context, flow over such geometries with blowing and suction scenario finds its importance and is studied for different  $L_{max}/L_{min}$  models namely 3, 4 and 5. Initially, it is found that for  $L_{max}/L_{min} = 5$ , the re-circulation and loss zones are more. Further, the  $L_{max}/L_{min} = 5$  configuration is subjected to different operating conditions like blowing and suction. For further improvement of the flow, the blowing is subjected to different heads of pressure like 200 mm and 300 mm of water and suction.

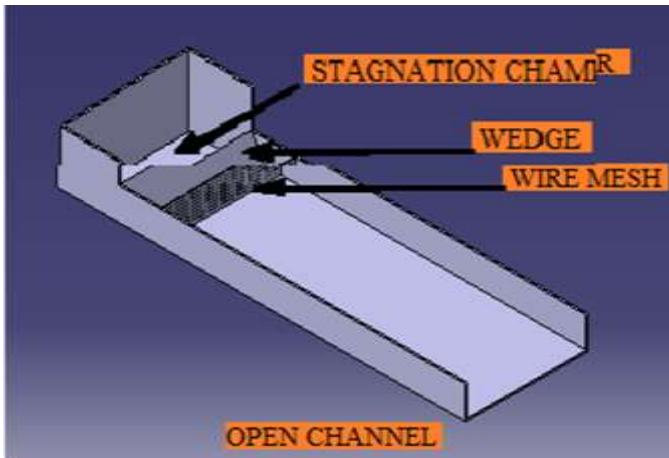

(a) Design and fabrication of open channel.

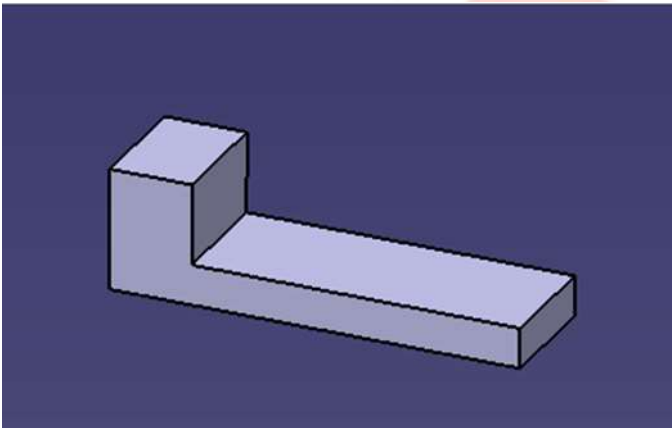

(b) Basic model of  $L_{max}/L_{min} = 5$

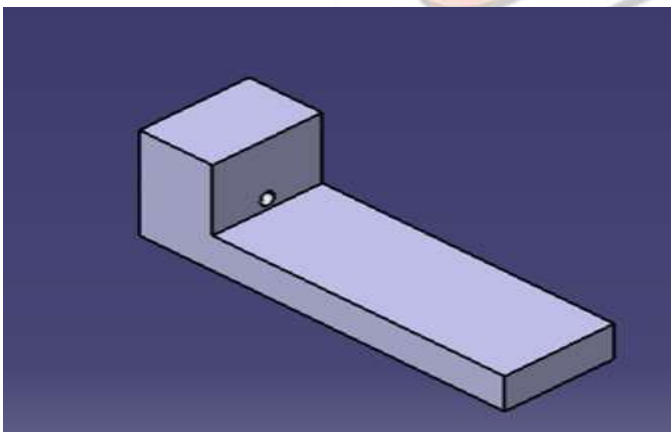

(c) Model of  $L_{max}/L_{min} = 5$  with suction hole

### III DESIGN OF OPEN CHANNEL AND MODELS

#### EXPERIMENTAL SETUP

Flow visualization is proved as one of the best techniques for describing and evaluating the flow features of all realistic problems like gas or wind turbines, in both subsonic and supersonic speeds. Previously, researchers developed many techniques such as smoke flow visualization, tufts and chemical coating, shadowgraph and schlieren techniques to study the low motion over the objects. When compared to these, open channel is the cheapest technique used to visualize this scenario. The experimental system considered in the present work mainly consists of four parts, viz., water chamber, wedge, wire mesh



and test section as shown in Fig. 3. Water chamber is used to store water from any external source. Function of wedge is to allow the flow uniformly into the channel. In other words, it acts as a spillway to the water chamber. By using the wedge, we can also reduce the effect of turbulence in water. Function of the wire mesh is to condition the flow to fairly uniform and laminar, before it goes to the test section. The area of the channel next to the wire mesh is treated as the test section, where the objects are tested. The test section is calibrated with the scale and angles, for the direct measurement of different parameters.

#### IV RESULTS AND DISCUSSION

The present work aims at understanding flow separation, recirculation, attachment and reverse flow phenomenon. These flow features are highly complex to deal with. An attempt has been made to understand them in case of sudden expanded geometries. Usually, the models are designed to understand the effect of length and height on the complex flow phenomenon. Flow scenario is explained in both the cases and comparison is made without blowing and suction. Based on these studies, depending on the application, guide vanes and rotor blade heights are designed in case of wind or gas turbines. With improved flow structure, these studies pave the way for clean and sustainable working environment.

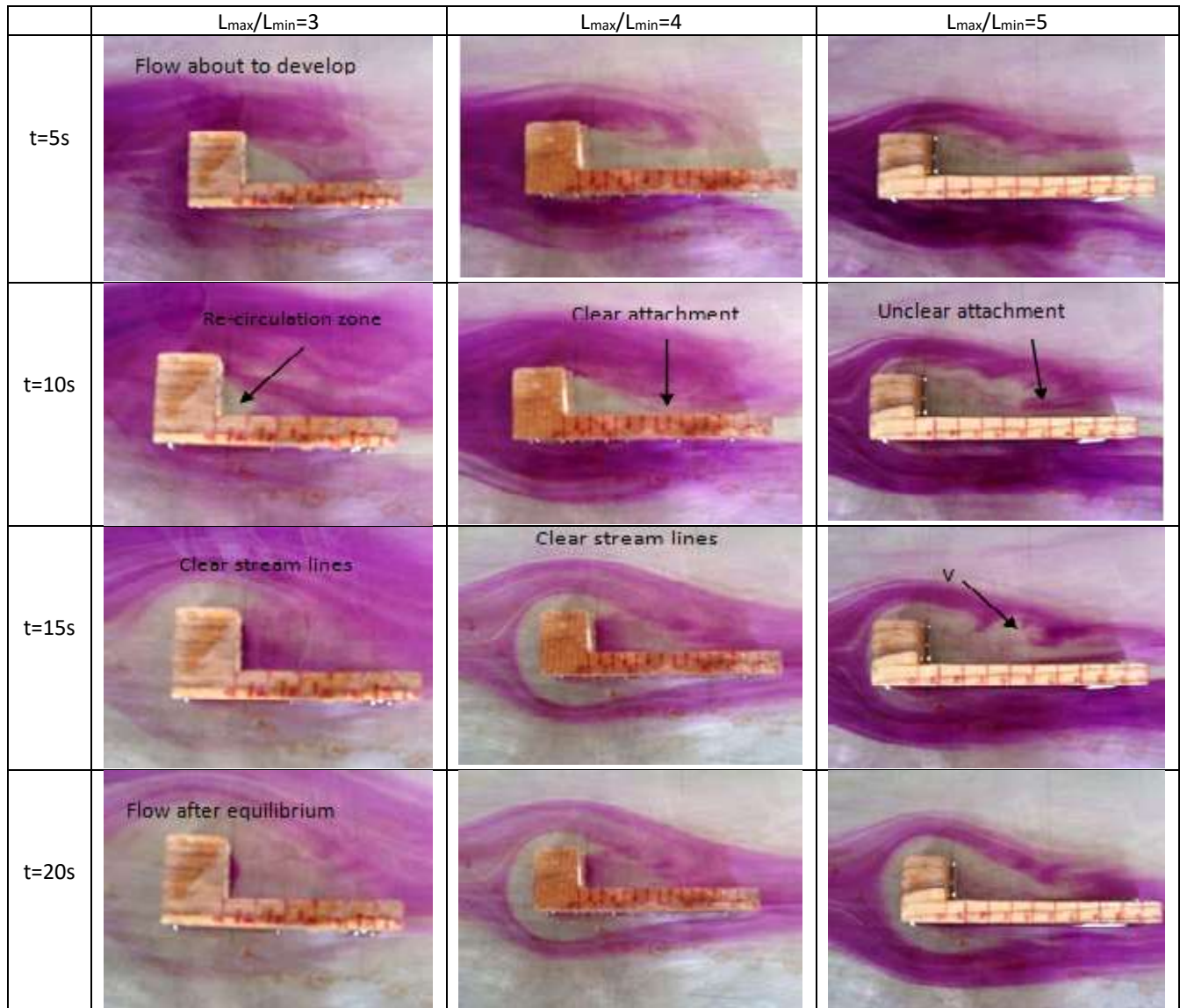

Figure .4 Flow Structure Over The Models Of  $L_{max} /L_{min} = 3, 4$  And  $5$  Without Blowing And Suction.

#### FLOW DEVELOPMENT OVER THE MODELS WITHOUT BLOWING AND SUCTION

Fig. 4 represents the flow behavior over the models of  $L_{max} /L_{min} = 3, 4$  and  $5$ , without blowing and suction. In this, all the complex flow features like separation, attachment point, vortex size and recirculation regions at  $t = 15s$  can be identified. For  $L_{max} /L_{min} = 3$ , flow attaches to the wall at  $2.25$  (attachment point / step height). For  $L_{max} /L_{min} =4$ , flow attaches to the wall at  $2.5$  and for  $L_{max} /L_{min} = 5$ , the flow attaches to the wall at  $3$  from the vertical wall as shown in the figure. As the time

passes, the attachment point shifts towards the base of the model leading to the formation of vertical streamline flow (vortex) and re-circulating zone.  $L_{max} / L_{min} = 3$  is showing small re-circulation zone than  $L_{max} / L_{min} = 5$ . For  $L_{max} / L_{min} = 4$ , the streamlines are not so clear. For  $L_{max} / L_{min} = 5$ , the flow creates large vortex with high intensive recirculation which results in rotational flow. This rotational flow at the rear side of an automobile gives the dragging nature which causes the reduction in the mileage of vehicle. The following sections are used to analyze the methods to reduce the vortex and re-circulation region in order to improve the flow scenario. To meet this, different operating conditions are considered.







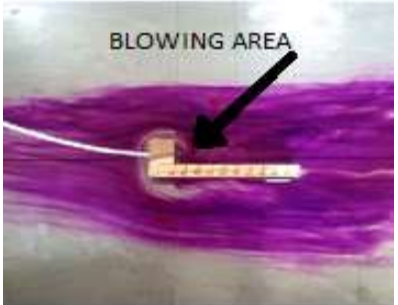

	WITHOUT BLOWING AND SUCTION	BLOWING AT 300 mm OF WATER WITH SINGLE INJECTION	WITH SUCTION
t=5s			
t=10s			
t=15s			
t=20s			

Figure 5. Flow Structure Over The Model Of  $L_{max} / L_{min} = 5$  With And Without Blowing And Suction.

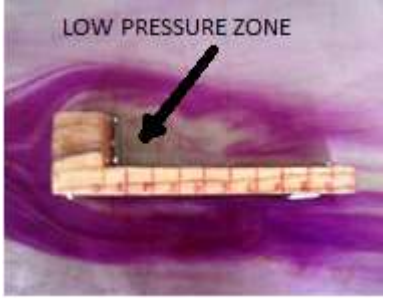
**FLOW DEVELOPMENT OVER THE MODEL  $L_{MAX}/L_{MIN} = 5$  WITHOUT AND WITH BLOWING AND SUCTION**

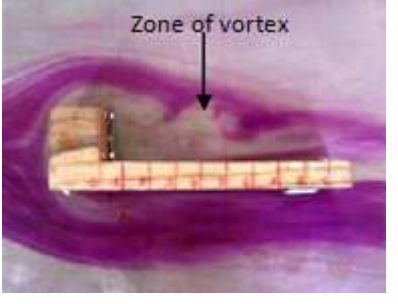
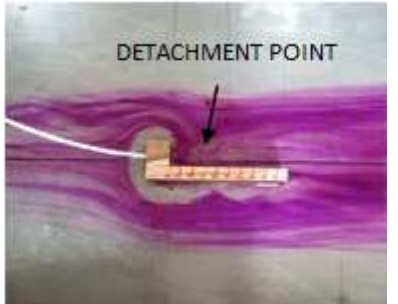
Figure 5 represents the flow structure over the model of  $L_{max} / L_{min} = 5$  with and without blowing and suction. When there is no blowing and suction, flow attaches to the wall at a distance of 3 from the wall and this value is reduced to 0.25 for blowing. As the time passes flow gets attached to the vertical wall itself, which means no separation from the geometry. Later, flow attached to the wall moves downward along the wall and then moves upward causing the detachment point at a distance of 1. After detachment point, flow reattaches to the wall and forms secondary recirculation zone. Similarly with suction, flow is attached to the wall at a distance of 1 from the vertical wall. As the time progresses, flow moves towards the base of the model and moves along the geometry. This leads to the elimination of recirculation zone and vortex, which are very much desirable in sudden expansion geometries. Blowing makes the vortex and primary re-circulation zones vanish, but form the secondary re-circulation zone. In case of suction, these vortex and re-circulations are completely eliminated and flow moves as per change in the geometry. This is because of creating strong low pressure zone by the suction which enables to suck all the

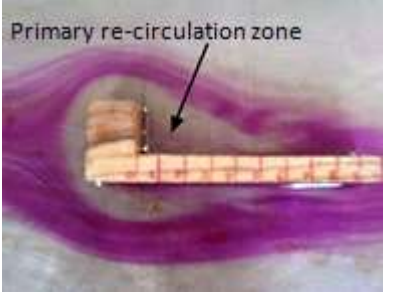
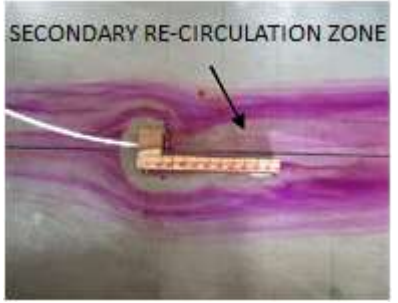

fluid particles (which are at the separation point) towards the corner. This makes the fluid particles follow the geometry of expansion without recirculation. At  $t = 15s$ , the streamlines for without blowing and suction are not clear and they are in rotational mode because of presence of the vortex and re-circulation region. In case of blowing, the streamlines are in well-defined path and are very clear. For suction, these streamlines are not clear as observed in the figure. This suggests the variation of flow scenario with various conditions of blowing and suction for the same  $L_{max} / L_{min}$ . Study also reveals that such flow loss regions can be easily negotiated.





	BLOWING AT 200 mm OF WATER WITH SINGLE INJECTION	BLOWING AT 300 mm OF WATER WITH SINGLE INJECTION.
t=5s		
t=10s		
t=15s		
t=20s		

Figure 6. Flow Structure Over  $L_{max}/L_{min} = 5$  For Blowing At Heads Of 200 And 300mm Of Water

**Flow Development Over The Model  $L_{max} / L_{min} = 5$  With Blowing At Different Pressures**

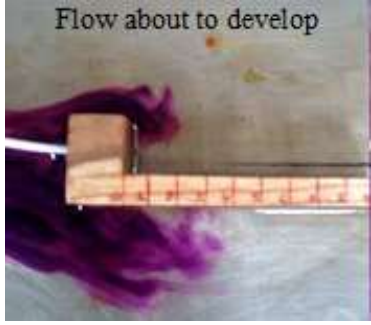
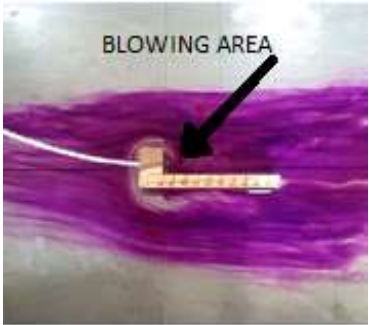
Figure6 represents flow structure over the model of  $L_{max}/L_{min} = 5$  for blowing at different pressure heads. With blowing at 200mm of water, attachment point occurs at 0.25 in the beginning of the flow. Because of pressurization in the corner, the flow is pushed to the downstream direction without re-circulation that leads to elimination of vortex and re-circulation. With increase in blowing pressure different flow structures are observed. Blowing at 300 mm of water, flow experiences different structure than the earlier one. Initially, the flow attaches at 0.25 from the vertical wall. With increase in pressure at the corner of model which results in the elimination of primary recirculation zone and formation of secondary recirculation zone. By comparing these, it is identified that vortex and re-circulation zones are eliminated in case of blowing at 200 mm

of water, when  $t = 15s$ . But, in the case of blowing at 300 mm of water, flow attaches to the vertical wall itself and moves downstream by attaching the wall up to 1 from the vertical wall. After that flow experiences complex phenomena, where flow is detached from the wall and forms secondary re-circulation zone.

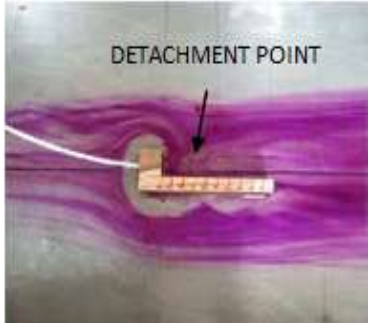
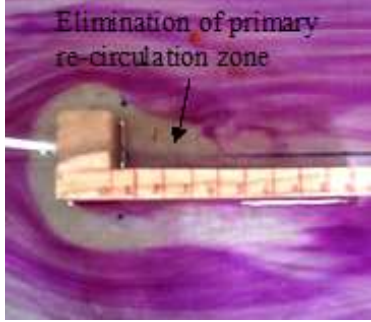
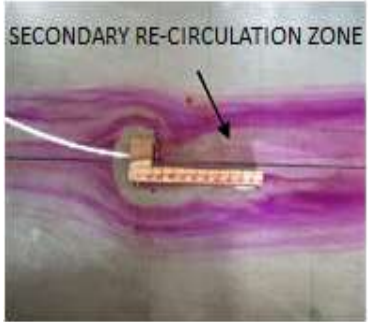
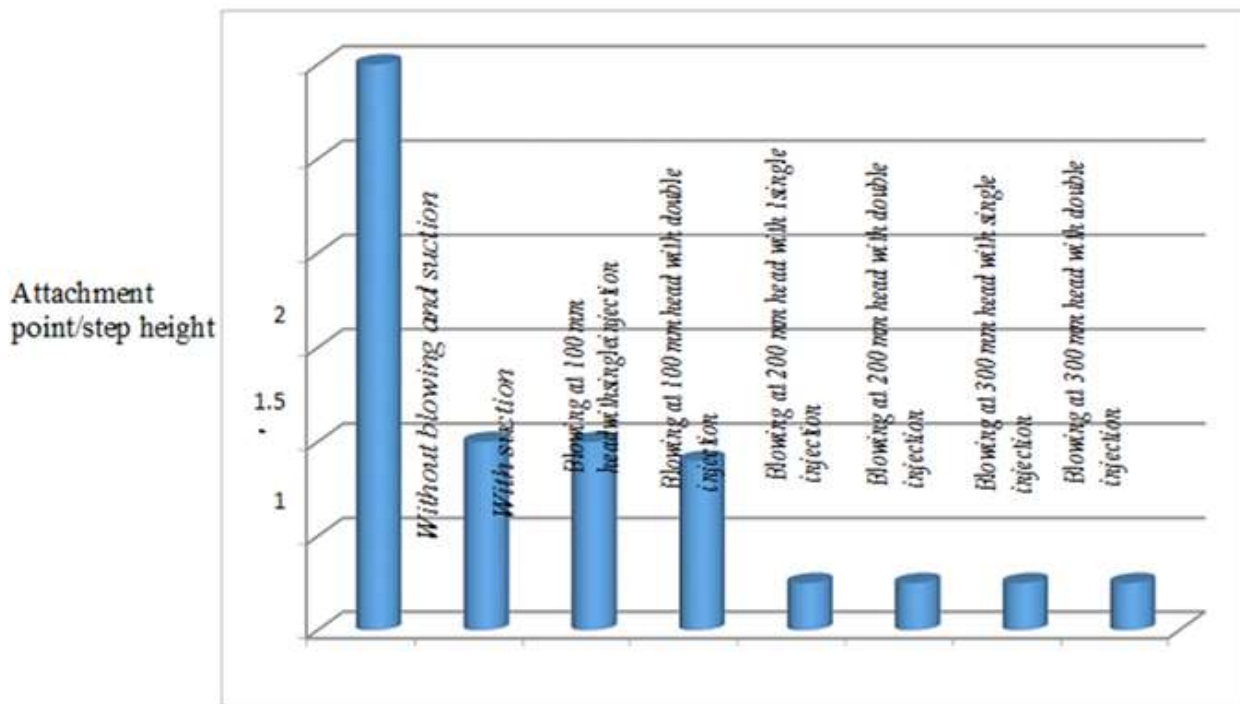

Figure7. Variation Of Attachment Point/Step Height On  $L_{max}/L_{min} = 5$ , For Different Operating Conditions.

#### Comparison of attachment point/step height for $L_{max}/L_{min} = 5$ with different operating conditions

Fig. 7 represents variation of attachment point/step height for  $L_{max}/L_{min} = 5$  at various operating conditions. The attachment point/step height occurs at 3 for without blowing and suction from the vertical wall and this value is reduced to 0.25 for blowing at 200 and 300 mm of water with single and double injections as shown in Figure. But using 300 mm of water we can eliminate the primary recirculation zone completely but creates secondary recirculation zone. The reduction in recirculation zone size is possible up to 12 times with blowing at 200 mm, 300 mm of water with single and double injections. For suction, initially flow occurs at a distance of 1 from the vertical wall and slowly moves in the reverse direction finally attaches to the vertical wall itself. This eliminates the aspect of re-circulation and vortex formation in the sudden expansion geometries.

#### CONCLUSIONS

Flow structure over sudden expansion geometry is experimentally studied for different configurations involving varied  $L_{max}/L_{min}$  values. The vortex size and re-circulation zones increase as the  $L_{max}/L_{min}$  value is increased. These flow loss regions are reduced by using blowing and suction. With blowing at 300 mm of water, the vortex and primary re-circulation zones are eliminated, but secondary re-circulation zone is formed. Using suction, elimination of vortex and re-circulation zones is absolutely possible. With blowing at 200 mm of water, flow can be pushed to downstream without re-circulation. Such improvement of flow will be helpful directly or indirectly as per the application of use. This indirectly helps the power generation unit like gas or wind turbine to improve its performance.

#### REFERENCES

- [1] Y. Bae, Y. Kim, "Prediction of local pressure drop for turbulent flow in axi-symmetric sudden expansions with chamfered edge", *Chemical Engineering Research and Design*, vol. 92(2), 2014, pp. 229 - 239.
- [2] C. Dales, M.P. Escudier, R.J. Poole, "Asymmetry in the turbulent flow of a viscoelastic liquid through an axisymmetric sudden expansion", *J. Non-Newtonian Fluid Mech*, vol. 125, 2005, pp.61 - 70.
- [3] I. Dağtekin I, M. Ünsal, "Numerical analysis of axi-symmetric and planar sudden expansion flows for laminar regime", *International Journal for Numerical Methods in Fluids*, vol. 65(9), 2011, pp. 1133-1144.
- [4] S. Dhinakaran, M.S.N. Oliveira, F.T. Pinho, M.S. Alves, "Steady flow of power-law fluids in a 1:3 planar sudden expansion", *Journal of Non-Newtonian Fluid Mechanics*, vol. 198, 2013, pp. 48 - 58.
- [5] V.V.R. Kaushik, G. Sumana, D.A.S. Gargi, K.D. Prasanta, "CFD simulation of core annular flow through sudden contraction and expansion", *Journal of petroleum science & engineering*, vol. 86-87, 2012, pp. 153-164.
- [6] G.C. Layek, C. Midya, S. Mukhopadhyay, "Effects of Suction and Blowing on Flow Separation in a Symmetric Sudden Expanded Channel, Modelling and Control", vol. 13(4), 2008, pp. 451 - 465.

- [7] B. Pak, Y. Cho, S. Choi, “Separation and reattachment of non-newtonian fluid flows in a sudden expansion pipe” , Journal of Non-Newtonian Fluid Mechanics, vol. 37(2), 1990, pp. 175 - 199.
- [8] C.H. Tsai, C.P. Yeh, C.H. Lin, R.J. Yang, L.M. Fu, “Formation of recirculation zones in a sudden expansion microchannel with a rectangular block structure over a wide Reynolds number range” , Micro fluidics and Nan fluidics, vol. 12, 2012, 213 - 26.

