

Dynamic Voltage Restorer for Power Quality Improvement in Distributed Power System by ANFIS Controller

1Dr.S.Satthiyaraj, 2Dr.Anandhi
1Faculty, 2Faculty
1University College of Engineering Panruti,
2Pondicherry University

Abstract - The Power Quality analysis should provide improved power quality with the application of power electronics for the benefit of electricity consumers. The research work includes in-depth analysis of the interaction among loads, power networks and different power quality improvement devices. It sequentially drives to better design of mitigation materials like Dynamic Voltage Restorer (DVR) to relieve different power quality related problems. The main objective of this study is to produce a model of DVR. DVR is one of the custom power devices that are used as a practical solution for the protection of sensitive loads upon voltage disturbances in power distribution system. The execution of the DVR depends on the achievement of the control technique, which involved in switching of the inverters. The validity of the proposed method and achievement of the desired compensation are confirmed by the results of the simulation in MATLAB/ Simulink. The Adaptive Neuro-Fuzzy Interference (ANFIS) based DVR has been achieved and it have been verified that its transient response is better than the PI and Fuzzy Logic Controller response.

keywords - ANFIS, DVR, Power Quality, Active and reactive power

I. INTRODUCTION

Electric power system is a group of electrical equipments intended to supply, transmit and distribute the electric power. Electrical power system can be extensively divided into the alternators that supply the power, the transmission unit that conveys the power from the power station to the load centres and the distribution network that nourishes the ability to close by household and commercial. Small power producer are additionally used in business structures, industry, medical centres and homes.

II. REVIEW OF LITERATURE

WHingorani N.G. et al. (2006), presents the concept of custom power device is now becoming familiar. The reliability of this power in terms of small interruptions and less variations will stem from an integrated solution to present problems of which a prominent feature will be the application of power electronics controllers to distribution systems.

Deepak Somayajula, et al. (2015), examined the idea of utilizing the DVR as a power quality improvement device. In the creators propose the use of the DVR with rechargeable vitality stockpiling at the dc-terminal to meet the dynamic power necessities of the network amid voltage fluctuations. Because of the high cost of rechargeable energy stockpiling, different sorts of control systems have additionally been created in writing to limit the dynamic power infusion from the DVR. There are different strategies to control the arrangement inverter to give dynamic voltage reclamation, and the vast majority of them depend on infusing a voltage in quadrature with cutting edge stage, so reactive power is used in voltage rebuilding. With this coordination, the DVR will have the capacity to autonomously remunerate voltage droops and swells without depending on the matrix to adjust for issues on the lattice.

Bhim Singh, et al.(2013), prevail lately, the utilization of energy converters for example diode rectifiers, thermistor converters has expanded in modern and private gear utilizing adjustable speed drives (ASDs) and power supplies. These drives draw supply from AC mains and capable in terminal voltage drop because of expanded burdens. The distribution static compensator (DSTATCOM) is utilized as a shunt-associated compensator, which can relieve problems related power quality issues.

III. DYNAMIC VOLTAGE RESTORER (DVR)

DVR injects a voltage component in series with the supply voltage as shown in figure, thus compensating voltage sags and swells on the load side.

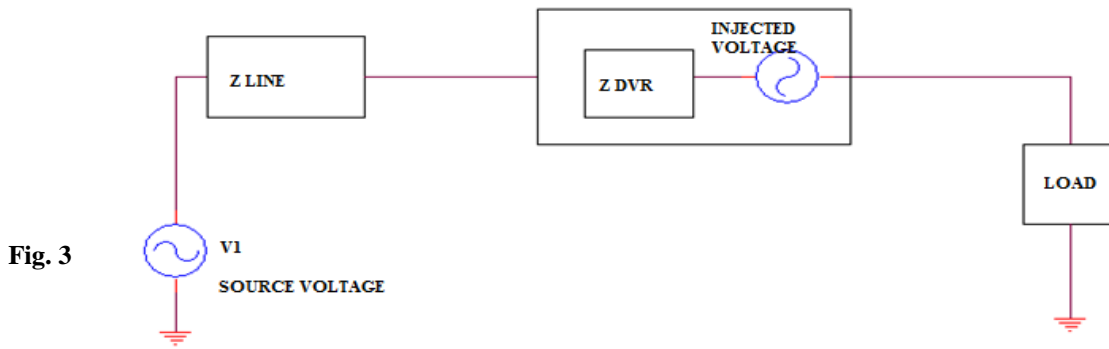

Fig. 3

Implementation of DVR in load centres

The Control response is on the order of 3millisec, ensuring a secure voltage supply under transient network conditions. Injection of voltage in different phases with respect to the load current implies real power transfer capability. The real power is transferred via the dc link, and is supplied either by a diode bridge connected to the ac network, a shunt connected PWM converter or by an energy storage device.

IV. ANFIS CONTROLLER BASED DVR

In distribution systems, to maintain and regulate the voltage, custom power devices may be used and it improves the quality of power at the customer side. In this work DVR is used which is connected in series to the distribution system through coupling transformer. The DVR consists of voltage source converter and energy storage device. Hybrid multilevel inverter used with five level output voltage with selective harmonic elimination pulse width modulation (SHEPWM) technique to decrease the harmonics since power electronics devices are used. Whenever voltage sag or swell occurs in the distribution side to maintain the load voltage, the appropriate voltage is injected in series which is controlled by ANFIS controller. The ANFIS based DVR is an FIS implemented in the network of an adaptive fuzzy neural network. ANFIS - DVR uses both the neural network and fuzzy logic approaches.

V. SIMULINK MODEL

A The simulation carried out by using MATLAB simulation software.

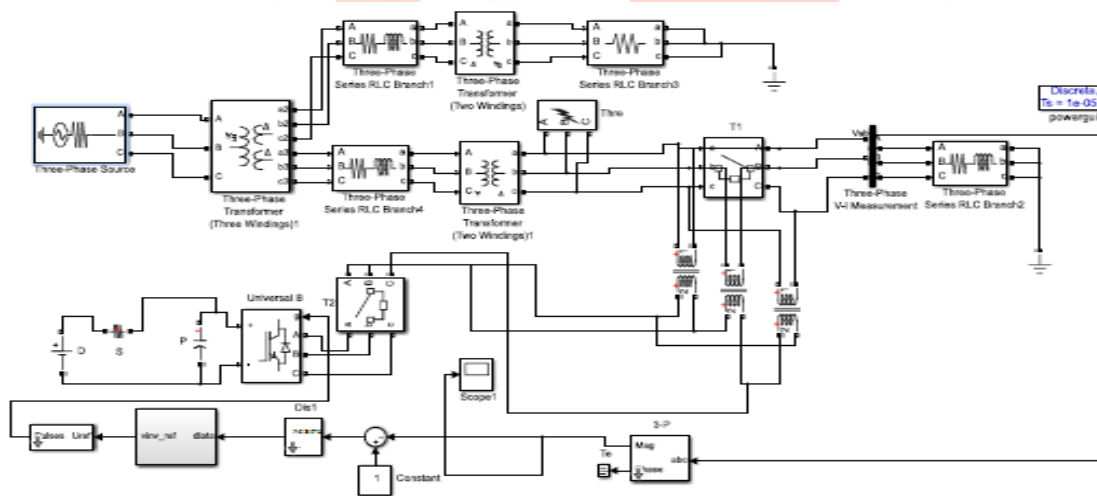
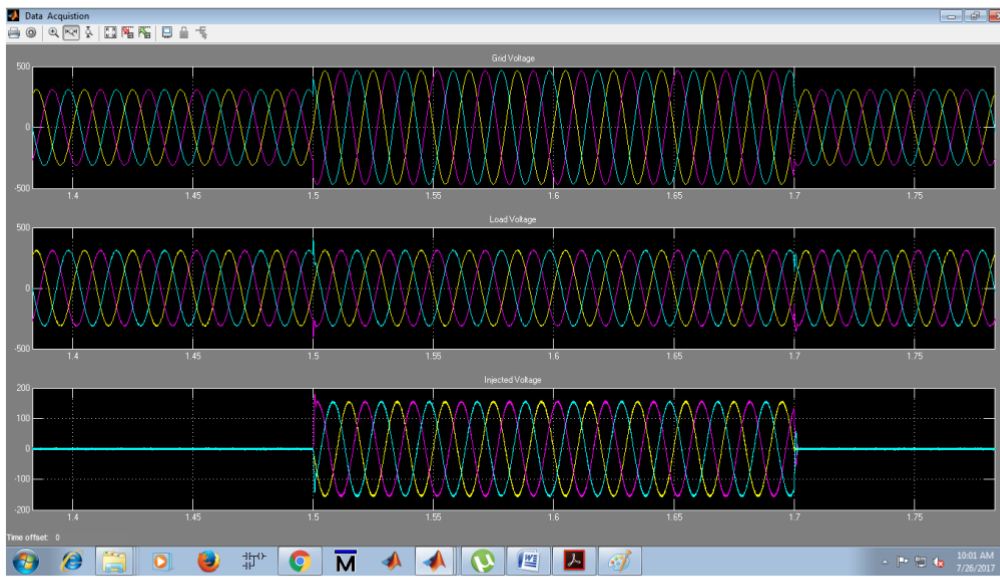

Fig. 2 Simulation model of DVR

VI. SIMULATION RESULTS

Fig. 3



Simulation of DVR response to a balanced voltage

From the simulation result of ANFIS based DVR controller, the various parameters like execution time, steady state error and total harmonic distortion was recorded and prepared as table and chart.

Table 1. Comparison of various parameters in DVR

Types of Controller used	Execution Time	Switching losses	Steady state error	Total Harmonic Distortion
PI	0.8417	0.66	1.5225	10%
FUZZY	0.701	0.6	1.4151	9.25 %
ANFIS	0.6002	0.56	0.9814	4.7 %

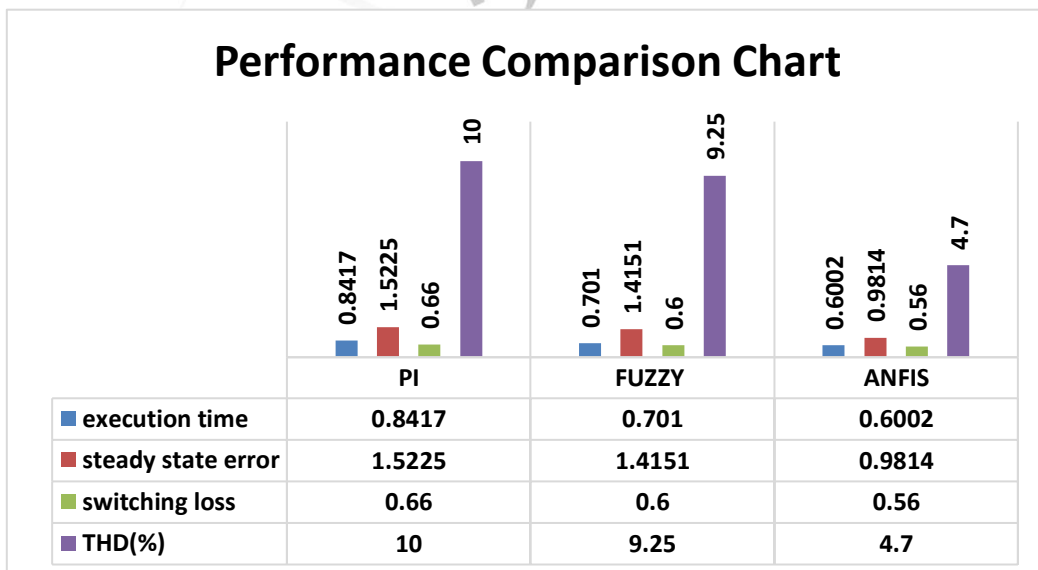

Fig. 4 Performance comparison of DVR with various controllers.

From the simulation result the ANFIS controller based DVR provides better performance in mitigating power quality problems than other controllers.

VII. CONCLUSION

The work done in this paper is to provide solutions to contribute the improvement of power quality by using ANFIS Controller based DVR in distributed power system. There are many types of controllers available for improving the power quality in power distribution systems. However, the nature and type of the load in the distribution system pollute the power system at the distributor end.

This paper mainly focused on different controller for DVR. The choice of a custom power device depends upon the type of load connected, supply configuration at PCC and its economics. During the comparison of various controllers, it has been found from the simulation result ANFIS controller based DVR has superior properties than PI controller and FUZZY controller.

REFERENCES

- [1]. Adly, M., Strunz, K. "Irradiance Adaptive PV Module Integrated Converter for High Efficiency and Power Quality in Standalone and DC Micro Grid Applications", IEEE Transactions on Industrial Electronics, Vol. 65, No.1, pp. 436-446, 2017.
- [2]. Akagi, H. "Classification, terminology, and application of the modular multilevel cascade converter (MMCC)", IEEE Transactions on Power Electronics, Vol. 26, No.11, pp. 3119–3130, 2011.
- [3]. Alfonso, P.T, Pedro, R.S., and Vicente, F.B. "A Two Degrees of Freedom Resonant Control Scheme for Voltage Sag Compensation in Dynamic Voltage Restorer", IEEE Transactions on Power Electronics, Vol. 33, No.6, pp. 4852-4867, 2017.
- [4]. Ami Pandya. "Power Quality Improvement using DVR (Dynamic Voltage Restorer)", International Journal of Innovative Research in Advanced Engineering (IJRAE), Vol.1, No.1, pp.1-8, 2015.
- [5]. Anil, J. "Power Converters, Control and Energy Management for Distributed Generation", IEEE transactions on Power System, Vol. 62, No.7, pp. 567-589, 2015.
- [6]. Avinash, R., Ramu, M., Kumar, S. Ramana "Analysis of DVR Performance for Voltage Flicker Mitigations in Distribution System Using Fuzzy Logic as a Controller", International Journal of Scientific & Engineering Research, Vol. 5, No.4, pp.101-105, 2014.
- [7]. Bae, B., Lee, J., Jeong J. and Han, B. "Line-Interactive Single-Phase Dynamic Voltage Restorer with Novel Sag Detection Algorithm", IEEE Transactions on Power Delivery, Vol. 25, No.4, pp. 2702-2709, 2010.
- [8]. Bingsen Wang., Mahesh, I. "Operation and Control of a Dynamic Voltage Restorer Using Transformer Coupled H-bridge Converters", IEEE transactions on Power Electronics, Vol. 21, No.4, pp. 1053-1061, 2006.
- [9]. Changjiang Zhan, Ramachandaramurthy, V.K. Fitzer, C. "Dynamic Voltage Restorer Based on Voltage-Space-Vector PWM Control", IEEE Transactions on Industry Applications, Vol. 37, No.6, pp. 1855-1863, 2001.
- [10]. Changjiang Zhan., Arulampalam, A. and Jenkins, N. "Four-Wire Dynamic Voltage Restorer Based on a Three-Dimensional Voltage Space Vector PWM Algorithm", IEEE transactions on Power Electronics, Vol. 18, No.4, pp.1093-1102, 2003.