

# Design a 4 Channel Signal Conditioner for load cell and Develop a PCB

Arpita Gupta  
Student  
B.I.E.T. Jhansi

**Abstract** - This paper presents a systematic design of a 4-channel signal conditioning module and, also develops its PCB by using DIPTRACE. These circuit are used to perform the output signal from sensors of measurement strain s/s which is relevant for next stage of operation (procedure). Input signals as well as wave form passed by Signal Conditioner (SC) which consist DC voltage and DC current, AC voltage and DC current, frequency and electric charge. Outputs from signal conditioning module may be voltage, current, frequency, timer or counter, relay, resistance or potentiometer, and other specialized outputs.

**keywords** - LT SPICE Software, DIPTRACE Software, Signal Conditioner, Sensors, ADC

## INTRODUCTION

The persistence of data acquisition is to measure physical parameters from real life. Data acquisition system measures the physical parameters and shows the current value of the parameter with a computing device. Data acquisition system contains of various sensors, data acquisition hardware (DAQ unit) and a computing device as shown in the fig given below



Fig.1 Block diagram of computing device

Used to guide, monitor and sense physical parameter and forward the data through network to central computer. To amplification and convert the signal into compatible for DAQ system

Device that translate analog signal into digital by continuous transmission signal of amplify strength for take away data.

## PARTS OF DAQ SYSTEM

**SENSOR:** - Sensors are sophisticated device that are used to detect & react to electrical or optical signal. It is also known as transducer which converts a physical phenomenon into quantitative electrical signal.

**DAQ Devices:** - It acts as the interface between a computer and signal. It is the process of sampling signals that measure real world condition and converting the resulting samples into digital numeric value that can be manipulated by computer. It converts analog waveform into digital values for processing. The components of DAQ system include- Senso

Signal conditioning circuitry Analog to Digital converter

**COMPUTER:** - A computer have taken a major role in near every aspect of life in our modern world. They are electronic devices; all the information has to be digitally formatted. Nonlinearities in sensor output can be linearized by computer. Most sensor require some type of accommodation to their input into a linear voltage that can be measured by data acquisition computer.

## COMPONENTS OF THE BASIC DATA ACQUISITION SYSTEM(DAQ)

Transducers Signal conditioner Multiplexer

Analog to digital converter

Recorder devices and display devices

- **Transducer-** A transducer is used to convert the physical parameters coming from the field into electrical signals or it is used to measure directly the electrical quantities such as resistance, voltage, frequency, etc.
- **Signal Conditioner-** It is usually the output signals of the transducer will be of very low level (weak) signals which cannot be used for further processing. In order to make the signals strong enough to drive the other elements signal conditioners are used such as amplifiers, modifiers, filters etc.

- *Multiplexer*-The function of the multiplexer is to accept multiple analogues inputs (after signal conditioning) and provide a single output sequentially according to the requirements.
- *A/D Converter*-The analog-to-digital (A/D) converter is generally used to convert the analog data into digital form. The digital data is used for the purpose of easy processing, transmission, digital display and storage Processing involves various operations on data such as comparison, mathematical manipulations, data is collected, converted into useful form and utilized for various purposes like for control operation and display etc. The transmission of data in digital form is possible over short distances as well as long distances of and has advantages over transmission in analog form. The data can be stored permanently or temporarily and can be displayed on a CRT or digital panel.
- *Recorders and Display Devices*-In display devices the data is displayed in a suitable form in order to monitor the input signals. Examples of display devices are oscilloscopes, numerical displays, panel meters, etc.

A. **STRAIN MEASUREMENT**

Strain is a measure of material deformation in response to an applied force. It is a strain ( $\epsilon$ ) of stress divided by strain to given moduli's such as young's modulus & bulk modulus.

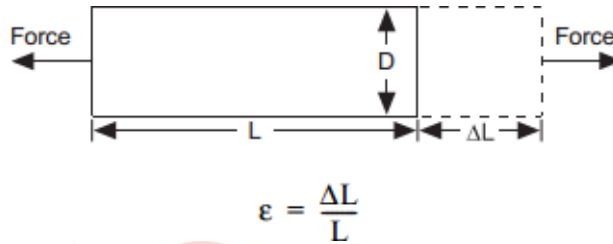

Fig.2 Strain measurements

Strain may be positive (tensile), negative (compressive) or dimensionless since it is the ratio of two lengths. But in practice, its units such as in./in. or mm/mm. S.I unit is newton per square meter which is equal to pascal.

$$1\text{Pa} = 1\text{N}$$

M2

Dimension of stress is same as that of pressure. When an external force is applied on an object, there is a bruise deformation in the shape of an object. this deformation in the shape of object is both tensile & compressive & measured by strain gauge.

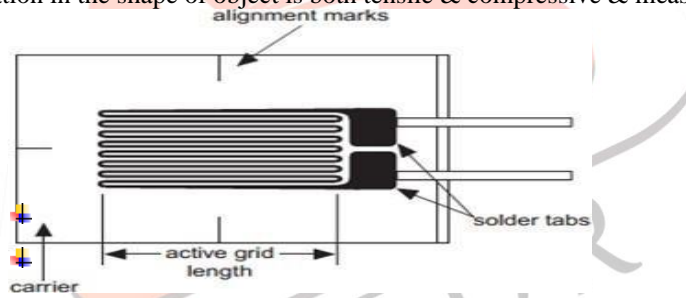

Fig.3 Strain gauge

It is type of sensor whose resistance varies when the force is to be applied. It converts force, pressure, tension etc. into electrical resistance than they are to be measured by measuring instrument. Gauge factor or strain factor is defined as the ratio of relative change in electrical resistance R to mechanical strain ( $\epsilon$ ). The gauge factor for strain gauge is typically 2. The string gauge is sensitive to that of small changes of an object by measuring the change of one object the amount of stress cab be calculated. The gauge is glued on to a device with help of an adhesive.

B. **WHEATSTONE BRIDGE**

It is the name given to a combination of four resistance connected to each other to give a null centre value. It is used to measure unknown resistance value using long resistive wires. It is nothing but have more then to series-parallel arrangement of resistance, connected between a voltage supply terminal & ground and produces or obtain zero voltage difference between two parallel branches when they are balanced It consists of 4 resistors built in such a way that is looks like a rhombus. As shown in figure

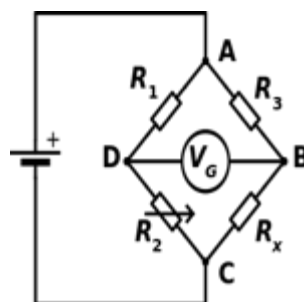

Fig.4 Wheatstone bridge

C. **SIGNAL CONDITIONER**

Signal conditioning circuits (SC) is used to convert the variation into an electric signal into a voltage level which is suitable for further processing. If the signal conditioning circuit is not designed properly then transducer may fail to deliver accurate & good results. The purpose of this signal conditioning device is to first amplify then convert the signal into a devisable form for DAQ system it can perform further number of different functions like Filtering, Interfacing with mP (ADC), Protection, Linearization, Current voltage exchange circuits, resistance change circuits error compensation etc.

#### D. BRIEF DETAILS OF THE LT SPICE.

LT spice stands for linear technology simulation program with integrated circuit emphasis. It is a high-performance SPICE simulator, which simulates the analog circuit. It is especially used in the field of integrated circuit and circuit board designing to analyze the behavior of circuit. It also simulates switch mode power supply and associated circuitry. It always runs on 32-bit based platforms. There are 2 ways to run LT Spice-

Schematic editor- used to enter circuit information.

Direct simulations- circuit is in form of net list (text input, no schematic).

#### DESIGNING AND DEVELOP A HARDWARE FOR AN AMPLIFIER FOR DESIRED GAIN OF 01 CHANNEL.

We know that, non-inverting operational amplifier circuit voltage gain of the circuit  $A_v$  is given by:

$$V_{out} / V_{in} = A_v = 1 + R_2 / R_1$$

So, as per desired requirement, gain ( $A_v$ ) is equals to 1000. But for sake of convenience for calculation of  $R_1$  and  $R_2$  we considered gain ( $A_v$ ) equals to 1001. So, let us consider  $R_1 = 1 \text{ K}\Omega$  then,

$$1001 = 1 + \frac{R_2}{R_1}$$

1

So,  $R_2 = 1000 \text{ K}\Omega$  Now, we have to design and develop hardware for an amplifier. For this we have to take  $R_1 = 1 \text{ K}\Omega$  and  $R_2 = 1000 \text{ K}\Omega$ , one op-amp IC-741 one dual power supply for  $V_{cc}$  and  $V_{in}$ . Let us consider  $V_{cc} = +12 \text{ V}$  and  $V_{in} = 0-5 \text{ mV}$  (varying it according to requirement) so, output comes to be in volts i.e.  $V_{out}$  is 0-5V. So, schematic for hardware and its output is given below

TABLE I: INPUT V/S OUTPUT VALUE

Input Signal (mV)	Output (V)	Output (mV)
0	0	0
2	1.945	1945
4	3.872	3872
6	5.979	5979
8	7.945	7945
10	9.875	9875
12	11.969	11969
<b>Gain</b>		<b>997.1429</b>

#### DESIGNING OF 04 CHANNEL SIGNAL CONDITIONING MODULE

##### A. Brief details

In this, we have to design 4 channel signal conditioning module, for this we have to design low pass filter, instrumentation amplifier and level shifter after designing all three, cascading them for getting desired result, first in LTspice (to check the schematic and desired output result as simulated result)

TABLE II: REQUIRED PARAMETERS

S. No.	Parameter	Values
1	Input Level	0 to 5 mV
2	Input Type	Analog Voltage
3	Filter Cut off frequency	0-100 Hz
4	Output Type	Analog Voltage
5	Output Signal Range	0 to 5 VDC
6	Supply Voltage	12 VDC
7	Number of Inputs	04

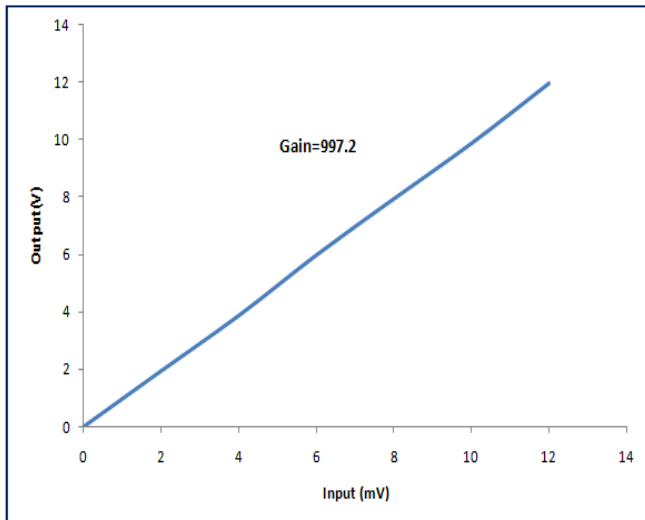

Fig.5 Input output graph of amplifier

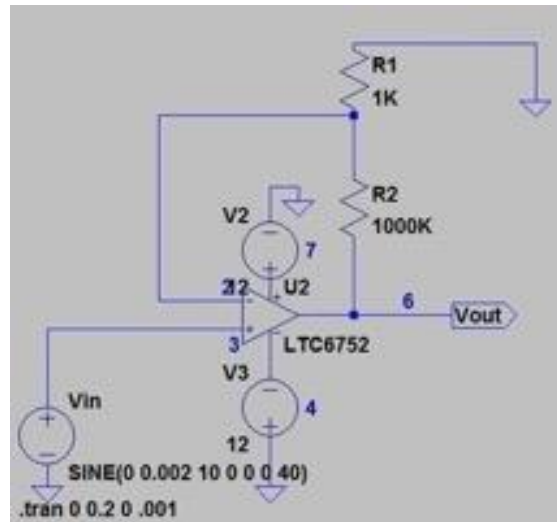

Fig.6 Non-inverting operational

**CIRCUIT DESIGNING**

A. Design a first order Low Pass Filter of cut-off frequency 100 Hz.

The relationship between RC and  $f_c$  for filter to get appropriate value of 'R' while considering the value of 'C' so,

$$2\pi f_c = RC$$

On considering  $C=0.001\mu F$ , we get,  $R=1.6M\Omega$  but for the sake of convenience we considered  $R=1M\Omega=1000K\Omega$ . For designing LPF, we have  $R=1000K\Omega$ ,  $C=0.001\mu F$ , dual power supply for  $V_{CC}$  and  $V_{in}$ , one op-amp IC 741.

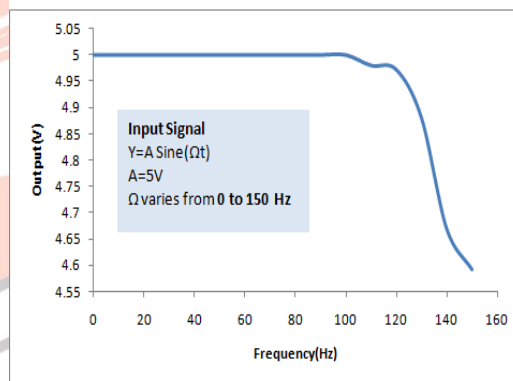
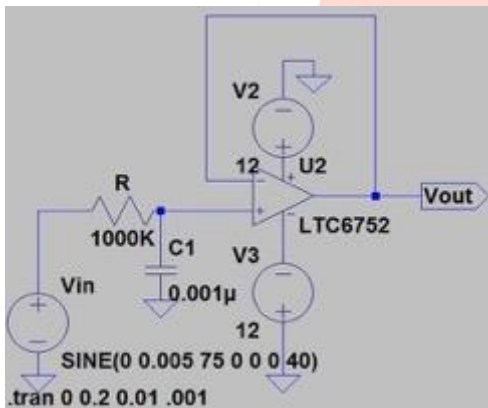

Fig.7 Schematic of Low Pass Filter & output graph (a) and (b)

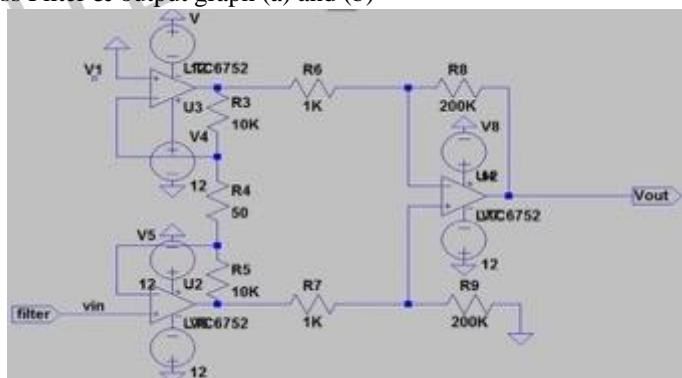
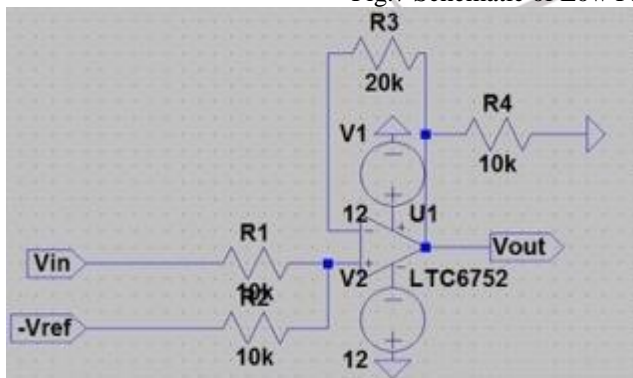

Fig.8 Schematic of instrumentation amplifier of Gain (AV) 1000 Fig.9 Schematic of level shifter

B. TO DESIGN A LEVEL SHIFTER.

The basic circuit diagram of level shifter for this signal conditioning module is given below

**RESULT :-THE OVERALL PCB SCHEMATIC OF 4 CHANNELS SIGNAL CONDITIONING MODULE**

For getting 1 channel SCM, we have to cascade filter, amplifier and level shifter to get desired output. Now, to get 4 channel SCM, we should design and develop PCB schematic to get desired PCB layout as shown in fig given below

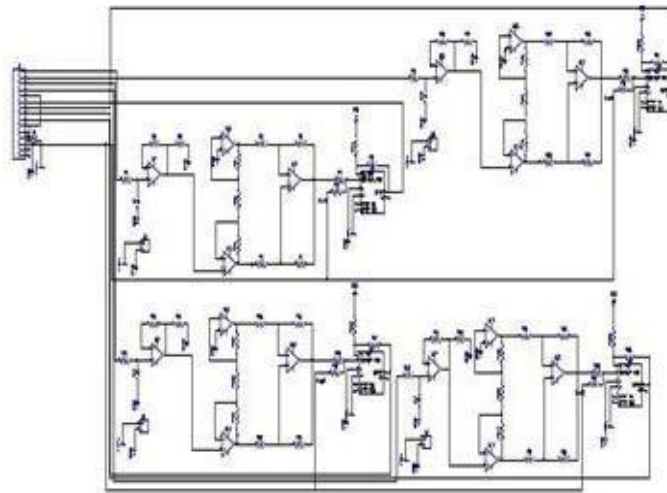
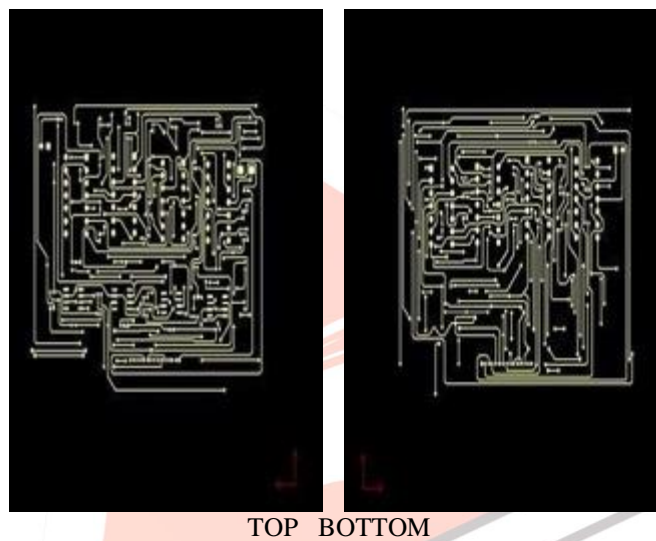

Fig.10 Layout of 4 channel SCM

### A. PCB LAYOUT



TOP BOTTOM

### CONCLUSION

At the last, but not the least, on the completion of project we conclude that the main objective project is to gain knowledge and learn the practical aspects of the field of electronics and its allied aspects. This project basically comprises of two parts. First part is the study and research of various topics like Data Acquisition System, Sensors and Transducers strain gauge etc. to the form the base of the second part of the project which is the development of PCB for 4 channels Signal Conditioning Module (SCM) using LTSPICE (Circuit Simulation software) and DIPTRACE (PCB design software).

### References

- [1]. Sawhney, A.K., Electrical and Electronics Measurement and Instrumentation, Dhanpat Rai & Co., Delhi: 2013
- [2]. National instruments Engineering, "Guide manual". [3]. Dip Trace, "User manual".
- [4]. Bakshi, U.V., Sensors and Transducers, Technical publication, Delhi.
- [5]. S. Johansson, Design of power supplies for Piezo LEGS and SiC experiment: KTH Student satellite MIST. 2016.
- [6]. T. Williams, EMC for product designers, 4th ed. Oxford, U.K.; Burlington, MA: Newnes, 2007.
- [7]. IEC 60050, -"International Electro technical Vocabulary - Details for IEV number 161-01- 07: 'electromagnetic compatibility' ". [Online].Available:<http://www.electropedia.org/iev/iev.nsf/display?openform&ievref=161-01-07>. [May 26, 2017].
- [8]. Texas, "PCB Design Guidelines for Reduced EMI Analog & Mixed-Signal".[Online].Available:[http://www.ti.com/analog/docs/litabsm\\_multiplefilelist.tsp?literatureNumber=szza009&docCategoryId=1&familyId=380](http://www.ti.com/analog/docs/litabsm_multiplefilelist.tsp?literatureNumber=szza009&docCategoryId=1&familyId=380). [Date: 26-may-2017].
- [9]. IEC60335,"Standard".[Online].Available:<https://webstore.iec.ch/publication/24738>. [May 26, 2017].
- [10]. "LT1129 -Micropower Low Dropout Regulators with Shutdown - LinearTechnology".[Online].Available:<http://www.linear.com/product/LT1129>. [May 26, 2017].



- [11]. LT8570, “Boost/SEPIC/Inverting DC/DC Converter with 65V Switch, Soft-Start and Synchronization - Linear Technology”. [Online]. Available: <http://www.linear.com/product/LT8570>. [May 26, 2017].
- [12]. Dip Trace, “Schematic and PCB Design Software”. [Online]. Available: <http://diptrace.com/>. [May 29, 2017].
- [13]. MIST group, “SiC Harnessing”. 2017.
- [14]. D. L. Jones, “PCB Design Tutorial Rev A”, Scribd. [Online]. Available: <https://es.scribd.com/document/10656556/PCB-Design-Tutorial-Rev-A>. [May 26, 2017].
- [15]. “Staying Well Grounded Analog Devices”. [Online]. Available: <http://www.analog.com/en/analog-dialogue/articles/staying-well-grounded.html>. [May 26, 2017].
- [16]. “PCB Printed Circuit Board File Creation Calculator in Advanced Circuits”. [Online]. Available: <http://www.4pcb.com/trace-width-calculator.html>. [May 26, 2017].
- [17]. Learn EMC, “Other Good EMC Design Guidelines”. [Online]. Available: <http://learnemc.com/other-good-emc-design-guidelines>. [May 26, 2017].
- [18]. C. Kueck, “Application Note 139”.
- [19]. Seeed Studio, “Fusion PCB Manufacturing & Prototype PCB Assembly”. [Online]. Available: [https://www.seeedstudio.com/fusion\\_pcb.html](https://www.seeedstudio.com/fusion_pcb.html). [May 26, 2017].
- [20]. I2C Info, “I2C Bus, Interface and Protocol”. [Online]. Available: <http://i2c.info/>. [May 26, 2017].
- [21]. STMicroelectronics, “STM32F3DISCOVERY - Discovery kit with STM32F303VCMCU”. [Online]. Available: <http://www.st.com/en/evaluation-tools/stm32f3discovery.html>. [May 26, 2017].
- [22]. STMicroelectronics, “STM32L0538DISCOVERY - Discovery kit with STM32L053C8MCU”. [Online]. Available: <http://www.st.com/en/evaluation-tools/stm32l0538discovery.html>. [May 26, 2017].
- [23]. Linear Technology, “LT3062 - 45V Vin, Micropower, Low Noise, 200mALDO”. [Online]. Available: <http://www.linear.com/product/LT3062>. [May 26, 2017].

