

Agri-Field Management System Using IoT

1Kishore G, 2Sethu A A

1Student, 2Student

1Kongu Arts and Science College (Autonomous), Erode,

2Kongu Arts and Science College (Autonomous), Erode

Abstract - The term IoT stands for the internet of things and can be defined as the interconnection between the individually identifiable embedded computing apparatus in the accessible internet infrastructure. The 'IoT' connects various devices and transportation with the help of the internet as well as electronic sensors. IoT sensors like DHT11 temperature and humidity sensors, and soil moisture sensors are very useful to monitor the temperature, humidity, and moisture of the crop and soil. The sensors are responsible for collecting the data from the crop and soil and they will send the data to Arduino UNO and Node MCU ESP8266. We can monitor all the levels from mobile applications, Websites 24X7 live. If the moisture level of the crop goes below the optimum level of the crop it will automatically start the irrigation and stops it once it reaches the specified level for the crop. It will improve plant's life and farmers can increase their production by lowering their production cost. IoT in agriculture uses robots, drones, remote sensors, and computer imaging combined with continuously progressing machine learning and analytical tools for monitoring crops, surveying, and mapping the fields, and providing data to farmers for rational farm management plans to save both time and money.

keywords - DHT11 Sensor, Soil Moisture Sensor, ESP8266 Module, Arduino Uno

I. INTRODUCTION

Most of the farmers in India use large portions of land for farming and it becomes very difficult for them to reach and track each corner of their large farms. Sometime there is a possibility of uneven water sprinkles. This result in the bad quality crops which further leads to financial losses. If the moisture level is high, it is favorable for the growth of Micro Organisms and it may lead to plant diseases. Hence it is necessary to monitor and maintain crops to increase their production.

II. OUR IDEA

- ✚ We have created Agri-Field Management System Using IOT for monitoring Temperature, Humidity and Soil Moisture level of crops in our farm through 24X7 Live Mobile Application and Website. We are using DHT11 temperature sensor and Soil Moisture Sensor connected to the Arduino UNO and ESP8266 for monitoring the crops in the soil.
- ✚ We have done a research based on Soil type and their Temperature, Moisture and Humidity level for various crops and found that our device is helping farmers to increase their yield and help them in saving their time and money.
- ✚ IoT is responsible for modernizing the agricultural field by using proficient methods and instruments to manage crops, soil, and animals. This in turn has led to decrease in the waste generation and a phenomenal increase in productivity.
- ✚ If the moisture level of the crop goes below the optimum level of the crop it will automatically start the irrigation and stops it once it reaches the specified level for the crop.

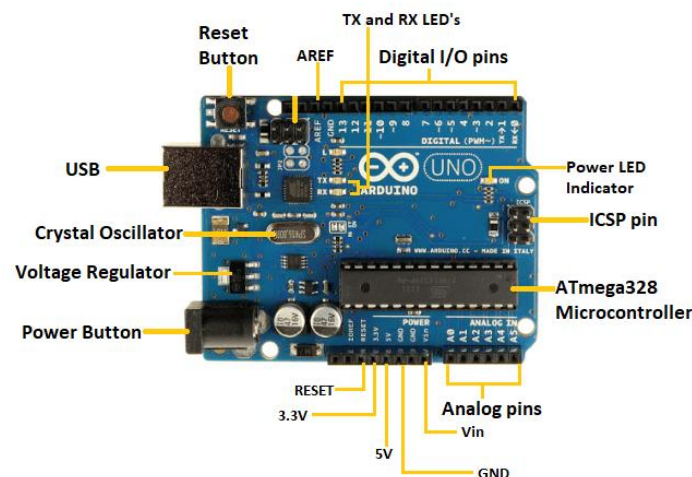

III. COMPONENTS USED

Arduino UNO Board

- The Arduino UNO is one of the most used microcontrollers in the industry. It is very easy to handle, convenient, and use. The coding of this microcontroller is very simple. The program of this microcontroller is considered as unstable due to the flash memory technology.
- The applications of this microcontroller involve a wide range of applications like security, home appliances, remote sensors, and industrial automation. This microcontroller has the ability to be joined on the internet and perform as a server too. There are Different types and versions of Arduino board and here we are using Arduino uno.

NodeMCU

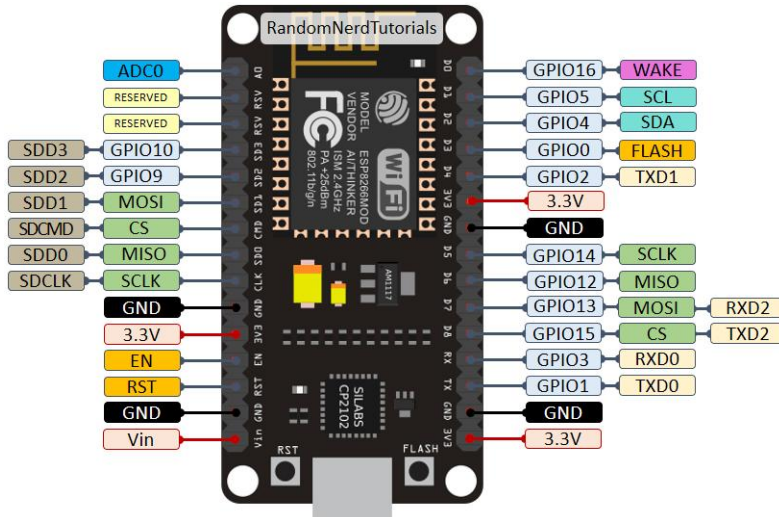

- ✚ NodeMCU is an open-source LUA based firmware developed for the ESP8266 wifi chip. By exploring functionality with the ESP8266 chip, NodeMCU firmware comes with the ESP8266 Development board/kit i.e. NodeMCU Development board.
- ✚ Since NodeMCU is an open-source platform, its hardware design is open for edit/modify/build.
- ✚ NodeMCU Dev Kit/board consists of ESP8266 wifi enabled chip. The ESP8266 is a low-cost Wi-Fi chip developed by Espressif Systems with TCP/IP protocol.
- ✚ The Wi-Fi module ESP8266 is a low-cost module, used to interface the microprocessors. It has a 96 KB of data RAM as well as a 64KB of instruction RAM.

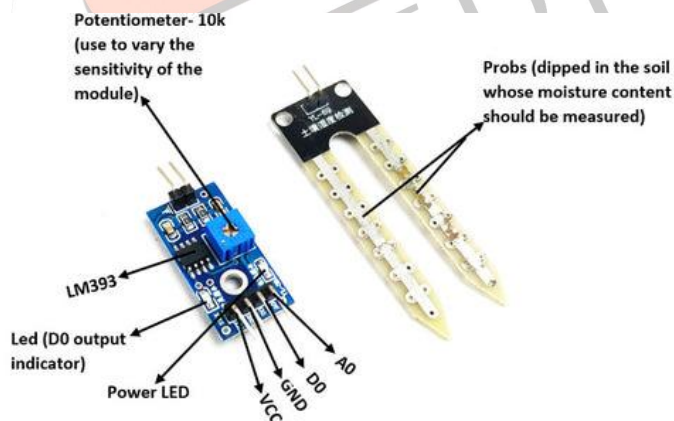

Soil Moisture Sensor

- ✚ Soil moisture sensor is one kind of sensor used to detect the soil moisture content. This sensor has two outputs like the analog output as well as the digital output.
- ✚ The digital o/p is permanent and the analog o/p threshold can be changed. The working principle of soil moisture sensor is open & short circuit concept. Here the LED gives an indication when the output is high or low.
- ✚ When the condition of the soil is dried up, the flow of current will not flow through it. So, it works like an open circuit. Therefore, the o/p will be maximized. When the soil condition is soaked, the flow of current pass from one terminal to the other. So it works like a closed circuit. Therefore, the o/p will be zero.
- ✚ Here sensor is coated with platinum, and anti-rust to make higher efficiency as well as long life. The sensing range is also high which will pay for the farmer at a minimum cost.

DHT11 Sensor

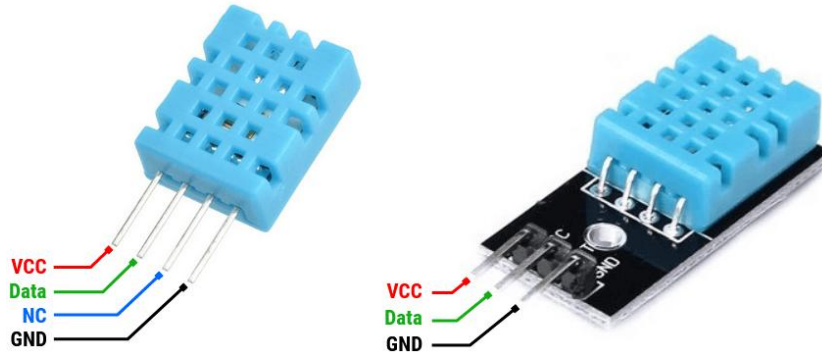

- ✚ The DHT11 is a commonly used Temperature and humidity sensor that comes with a dedicated NTC to measure temperature and an 8-bit microcontroller to output the values of temperature and humidity as serial data.
- ✚ The DHT11 is a basic, ultra low-cost digital temperature and humidity sensor. It uses a capacitive humidity sensor and a thermostat to measure the surrounding air and spits out a digital signal on the data pin (no analog input pins needed). It's fairly simple to use but requires careful timing to grab the data.

IV. CONSTRUCTION

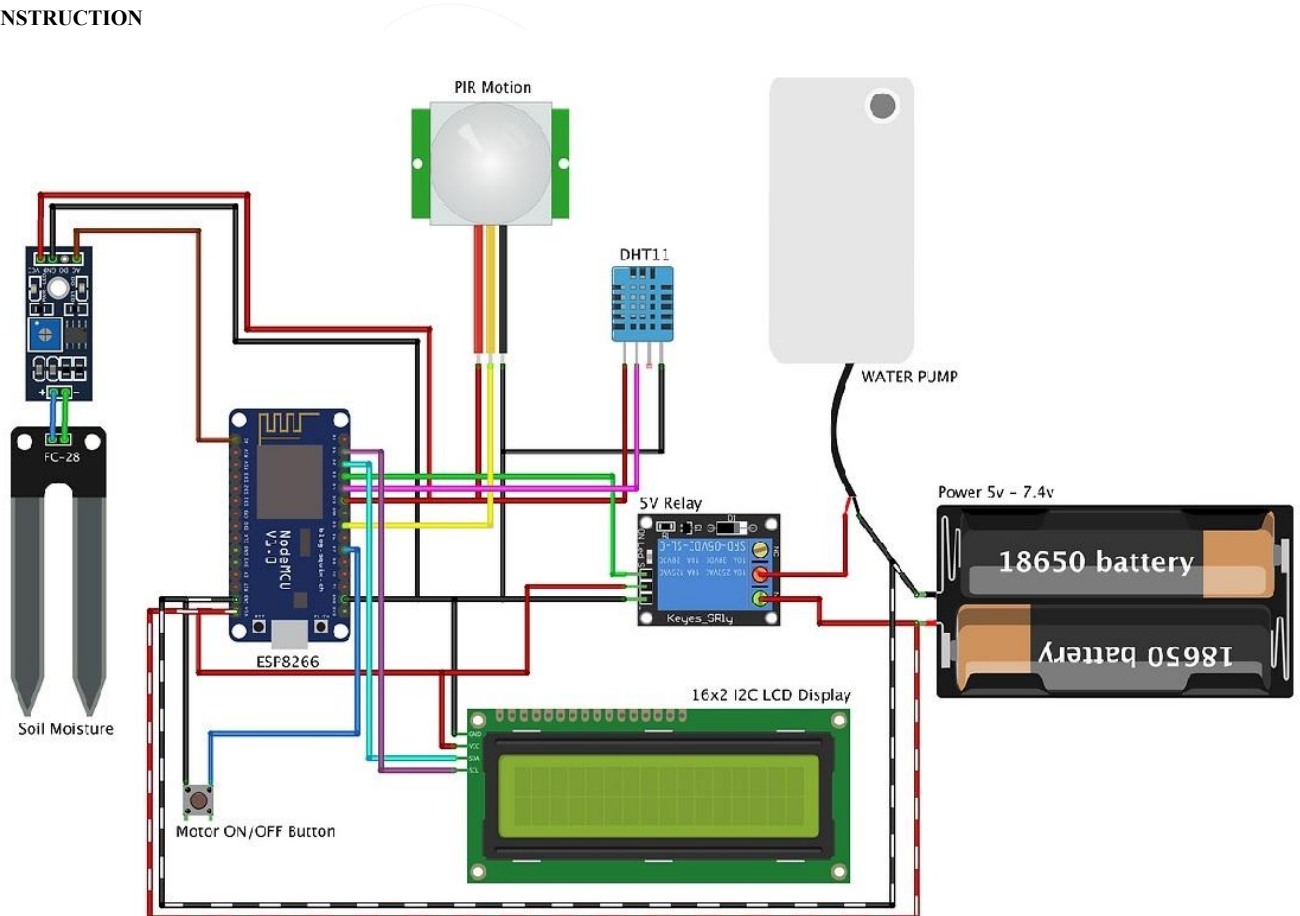

V. WORKING

Smart irrigation systems check the moisture levels in the water lanes that farmers make. They involve the use of Soil Moisture Sensor and Arduino boards. The main processing unit is the ESP8266 and the Arduino board is for each of the water lanes.

The Arduino boards are capable of connection to various sensors that are a part of the water lanes. These sensors collect vital information such as Temperature, Moisture, Humidity, and hydration levels of the soil.

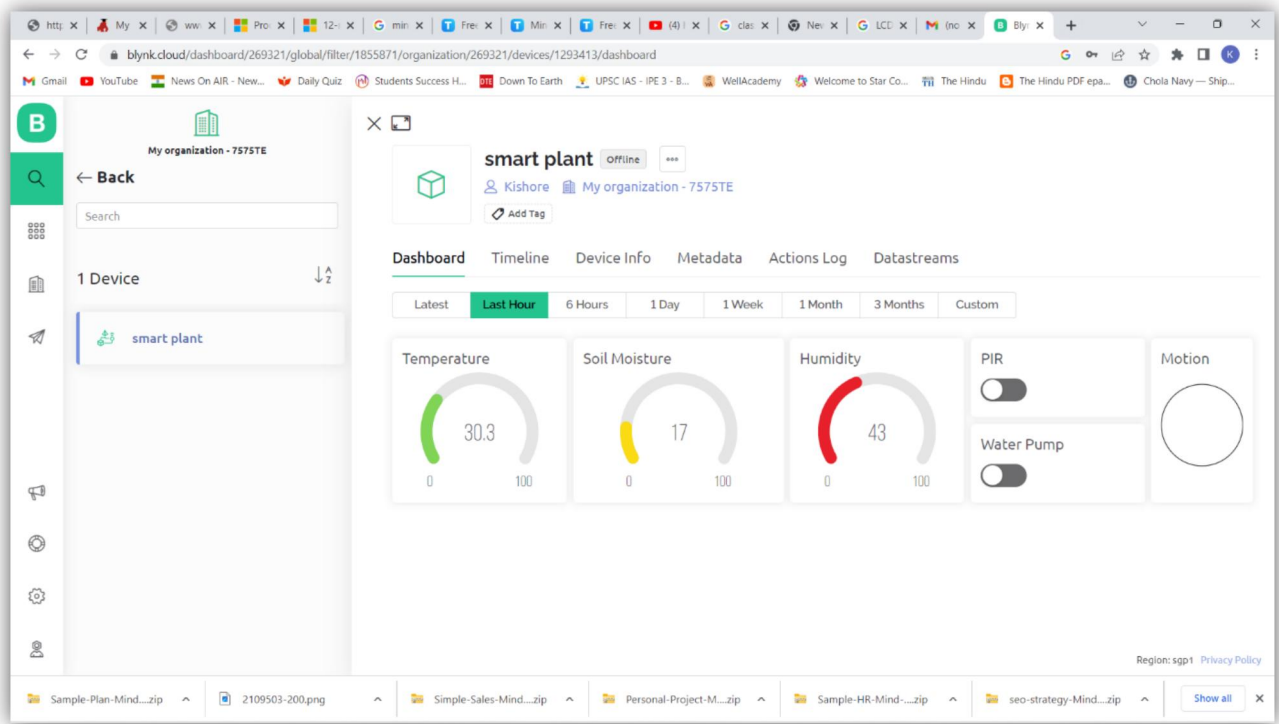

In case any water lane does not meet the moisture level that the farmer specifies, the Arduino boards send signals to the Arduino UNO that then alert the farmers to take the necessary steps.

It will automatically start the water pump and start irrigating the crops. If the moisture levels go beyond the limits it sends another signal to the Arduino UNO to stop the pumping. The farmers interact with application and send water to the lanes anytime according to their wish. The smart irrigation systems can be seen as gate-controlled systems that adhere the gates open only when the moisture content is less.

1. **Data collection**

- ✚ Farmers place sensors in the farm to gather information about the moisture levels in soil.
- ✚ For gathering Information about Temperature & Humidity of the soil, we are using DHT11 Sensor.
- ✚ For gathering Information about Moisture of the soil, we are using Soil Moisture Sensor.

2. **Diagnostics**

The data is then sent to clouds for processing. The data is interpreted to generate weighted outputs.

3. **Decision making**

- ✚ It is based on the processed data and the next step is taken with utmost care and precaution.
- ✚ It will decide the action based on data that we have provided to it by doing research on soil types and their Temperature, Humidity & Moisture.

4. **Action**

Once the decision has been made, it is time to take necessary action towards fulfilling the goals. It will start the irrigation or stop the irrigation or else send the notification of action to the farmer’s smart phone.

PROJECT OVERFLOW

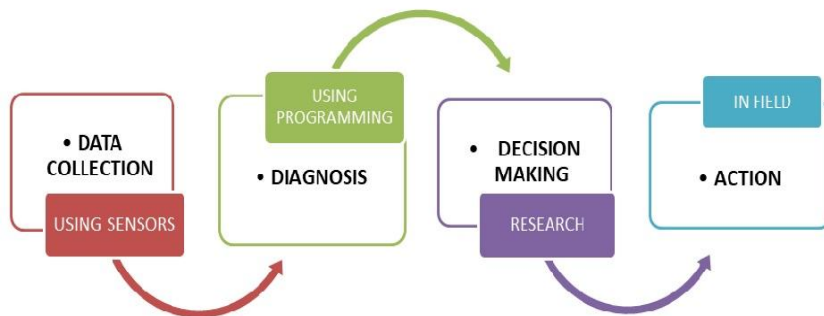

IoT based smart farming cycle

Data is the center of any IoT based technology. In order to ensure optimization, smart farms must form a continuous and constant cycle that collects and analyzes data to perform the next set of actions. The following is an example of a smart farming cycle:

- **Observation:** sensors are used to sense the surroundings and collect information about the soil, temperature, humidity and so on.
- **Diagnostics:** the information collected from sensors are sent to IoT based cloud platforms for data analytics.
- **Decisions:** based on the analysis done the farmers make relevant decisions to generate better outputs.
- **Actions:** when the tasks are operated the cycle repeats itself from the beginning.

IoT solutions for agricultural problems

IoT offers solutions to many of the agricultural problems. The most important IoT based solutions are precision farming and automated farming.

Precision farming

Precision farming is a modern approach which makes use of precision values to get an increased amount of yield and produce. It obtains accurate data and precision amounts about the agricultural lands. As a result of this, plants and animals get the exact amount of input they need as decisions are made for each plant or animal rather than the entire produce or cattle.

Precision livestock farming

The main target of PLF is to monitor, control and manage individual animals by using precision techniques that generate accurate data about individual cattle. Precision technology measures and collects data about the livestock 24 hours every day. The farms are notified in case something goes wrong with any farm animal. This allows the farmers to respond quickly to prevent disease outbreaks or any other setbacks.

Automation in smart greenhouses

Smart greenhouses are controls with devices such as temperature sensors and actuators. These devices capture and send information 24/7. This information is fed to clouds that later store the information in servers for future needs.

Once the performance analysis is done, lighting control and spraying activities are managed accordingly.

Agricultural drones

Farmers use drones to collect insight and real time information about crops and animals on the barns. The drones monitor the entire field from the sky and send alerts to the farmers in case of suspicious activity. These drones are also placed for security purposes.

Third green revolution- future of smart farming

Smart agriculture is taking over farms of all sizes by rapid speed. It is becoming a part of a movement that is known as the third green revolution. It involves the use of modern IOT devices such as security cameras, sensors, drones and actuators to manage agricultural yields. Smart agriculture has increased in profitability by providing help to both farmers and consumers.

IoT in agriculture

The world's population is growing by large percentages. Agriculture needs reforms to feed the world in large quantities. The internet of things allows the integration of technology with agriculture to provide better quality food, management, monitoring and control.

How automation and robotics help?

As the population rises the increase for food also certainly rises. In order for the demands to be met, we require automated methods that reduce the cost spent on manual labour. We also require methods that reduce the time taken to cultivate produce. All of this must be done keeping in mind the health of the individuals that will consume the produce. Semi-automatic robots could be placed in the fields in order to detect insects and pesticides to stop their growth at an early stage. These robots can also overlook heavy vehicles. The farmers can easily control these operations from the comfort of their homes. Smart irrigation systems check the water levels in the water lanes that farmers make. They involve the use of raspberry pies and Arduino boards. The main processing unit is the raspberry pi and the Arduino board is for each of the water lanes.

The Arduino Boards are capable of connection to various sensors that are a part of the water lanes. These sensors collect vital information such as moisture and hydration levels of the soil. In case any water lane does not meet the level that the farmer specifies, the Arduino boards send signals to the Raspberry Pi that then alert the farmers to take the necessary steps. The farmers interact with application to activate the relays that send water to the lanes as per the specified criterion. The smart irrigation systems can be seen as gate-controlled systems that adhere the gates open only when the moisture content is less. In case the moisture levels go beyond the limits it sends another signal to the raspberry pi to stop the pumping. This system leads to efficient uses of resources and reduction in water usage. Smart systems such as these increase productivity in agriculture.

Challenges in the modern agricultural city

Given below are some of the challenges faced by the farmers with the modernization of the farming industry:

- Lack of labour and human resources
- Global warming and greenhouse gases
- Manual intervention at a larger platform
- No proper monitoring systems
- Challenges in processing the large amount of non-uniform data

IoT analytics in agriculture

The data incoming from sensors is sent for further processing and analyzing. Smart farming integrates machine learning and predictive analysis to help farmers deal with natural calamities such as droughts and landslides.

Application of smart agriculture***1. Drone-based uses***

Smart farming also involves the deployment of drones to monitor areas from a remote location. Drones can reach places humans cannot reach. They are also capable of collecting information and data. They can send users data regarding soil, livestock, water levels and in addition help in the prevention of burglary attempts, crow attacks and so on.

2. Real-time crop monitoring

Temperature sensors, light sensors, motion sensors and various other smart sensors allow for retrieving real time updates about the crops. The farmers can remotely check on the status of the crop to ensure smooth functioning.

3. Livestock management

Sensors and smart cameras can count the number of animals such as hens and pigs on the farm. Sensors can also obtain health conditions about the animals on the farm. This helps in the early detection of flu breakouts and allows farmers to take necessary actions more quickly.

4. Tank level monitoring

IoT allows the remote mounting of water levels in huge tanks. It alerts the authorities when water levels fall below the average level in the tanks.

5. Smart greenhouse solutions

Greenhouses ensure that the plants meet the required level of oxygen levels. However, this procedure requires continuous monitoring and outside intervention. But a smart greenhouse uses IoT monitors and sensors that sense the atmosphere to send vital information for further analysis. This is a reliable and efficient procedure that curbs the level of harmful pollutants in the environment to a large extent.

6. Data analytics

Cloud and IoT platforms play an important role in smart agriculture systems. Sensors are the main source of data collection. However, if there is no proper mechanism to analyze the data then the information has no uses. The data undergoes predictive analysis and the cloud generates back a necessary action on the basis of the incoming data.

7. Infrastructure requirements

In order to implement smart farming, the farms require some basic infrastructure such as stable internet connection, hardware maintenance cost, huge investment on drones and sensors, a well trained staff and stable power connection.

Summary

In this article we looked in detail about the topic, smart agriculture. We learnt how to monitor the Temperature, Moisture and Humidity of crops and if the moisture level goes below the specified level it will irrigate the crops accordingly.

VI. ACKNOWLEDGMENT

We thank our beloved teachers **Mr. P. Ramesh, M.Sc (CS), M.Phil.**, Assistant Professor & Head, Department of Computer Science (UG), Kongu Arts and Science College (Autonomous), Erode, **Dr. R. Pushpalatha, M.C.A., M.Phil., Ph.D.**, Assistant Professor, Department of Computer Science (UG), Kongu Arts and Science College (Autonomous), Erode **Mr. M. Chandru, M.C.A., MBA., M.Phil., NIS(C).**, Assistant Professor, Department of Computer Science (UG), Kongu Arts and Science College (Autonomous), Erode, **Dr. A.K. Vidhya, M.Sc., M.Phil., PGDBI., SLET., Ph.D.**, Assistant Professor & Head, Department of Biochemistry, Kongu Arts and Science College (Autonomous), Erode, **Mr. R. Rasu, M.Sc., M.Phil., B.Ed., PGDBI., SET.**, Associate Professor, Department of Biochemistry, Kongu Arts and Science College (Autonomous), Erode and **Dr. N. Sangeetha, M.Sc., M.Phil., PGDBI., Ph.D.** Assistant Professor, Department of Biochemistry, Kongu Arts and Science College (Autonomous), Erode for their valuable guidance and consistent support in developing this idea into a Real-time Project. Because of their continuous support we are publishing this journal. We convey our sincere thanks and extreme gratitude to all of them.

VII. REFERENCES

- [1] Arshdeep Bahga & Vijay Madiseti "Internet Of Things A Hands-on-Approach" Universities Press (INDIA) Pvt Limited, 3-6-747/1/A&3-6-754/1, Himayatnagar, Hyderabad 500 029 (Telangana), India(*references*)
- [2] Miller Michael "Internet of Things, The: How Smart TVs, Smart Cars, Smart Homes, and Smart Cities Are Changing the World" Pearson Education Inc., First Edition 2015(*references*)
- [3] Cuno Pfister "Getting Started with the Internet of Things: Connecting Sensors and Microcontrollers to the Cloud" O'Reilly Media, Inc., First Edition 2011(*references*)