

Inductive Filtering Converter in HVDC Light Systems

¹Nidhi Mishra, ²Prerna Jain, ³Mrityunjaya Patted

¹Assistant Professor, ²Assistant Professor, ³Assistant Professor

Department of Electrical Engineering

JSPM'S Bhivarabai Sawant Institute of Technology and Research, Wagholi, Pune

Abstract - The Voltage source converter (VSC) based HVDC system is a relatively new technology for low and medium power transmission which can be connected to weak or even passive AC networks and is capable of supplying or absorbing reactive power according to the system operating conditions. The main switching component of the VSC is a high power high frequency static switch. A new voltage source inductive filtering converter (VSIFC) for HVDC Light transmission system which is mainly composed of the inductive filtering (IF) transformer and the related full-tuned (FT) branches with the commutating function for the self commutated converter. This paper concerns on the technical feasibility on the application of VSIFC in HVDC-Light systems. A typical test system for the proposed VSIFC-based HVDC-Light transmission is established in MATLAB/SIMULINK. Harmonic filters are installed on the PCC. The coupling transformer not only provides the suitable line-voltage for self-commutated converter, but also utilizes its leakage reactance efficiently to exchange active and reactive power between VSC and power system. It is worth to remark that although there is a special commutating reactor for VSC station, with the consideration that provide the suitable line-voltage for the operation of VSC station and prevent the 3-time harmonic currents from flowing into PCC, the coupling transformer is necessary to be installed.

Index Terms - HVDC Light, Voltage Source Converter (VSC), VSIFC (voltage Source Inductive Filtering Converter)

I. INTRODUCTION

In today's electricity industry, in view of the liberalization and increased effects to conserve the environment, HVDC solutions have become more desirable for the following reasons:

- Environmental advantages
- Economical
- Asynchronous interconnections
- Power flow control
- Added benefits to the transmission (stability, power quality etc.)

HVDC Light is a newly developed technology for electric power transmission by HVDC based on Voltage Source Converters. This has many interesting characteristics that make it a very Promising tool for transmission of electric power to distant loads, where no other transmission is possible or economic.

The HVDC technology has been successful to connect AC networks that for technical or economical reasons cannot be connected by AC transmission. The present technology uses circuits with PCC (Phase Commutated Converters) and is based on thyristor valves with semiconductor devices that can be turned on by a positive gate pulse when the main voltage is positive. To turn off the thyristors need a negative voltage across the main terminals. This is normally achieved by commutating the current to the valve in the next phase. Thereby the present technology has inherent weaknesses, which to some extent limit the use of HVDC as the means to overcome these weaknesses are relatively expensive

The HVDC technology has been successful to connect AC networks that for technical or economical reasons cannot be connected by AC transmission. The present technology uses circuits with PCC (Phase Commutated Converters) and is based on thyristor valves with semiconductor devices that can be turned on by a positive gate pulse when the main voltage is positive. To turn off the thyristors need a negative voltage across the main terminals. This is normally achieved by commutating the current to the valve in the next phase. Thereby the present technology has inherent weaknesses, which to some extent limit the use of HVDC as the means to overcome these weaknesses are relatively expensive.

II. DIFFERENCE BETWEEN CLASSICAL HVDC AND VSC-HVDC ADVANTAGES

The main difference in operation between classic HVDC and VSC-HVDC is the higher controllability of the latter. This leads to a number of new advantages and applications, some of which are given below-

1. Classic HVDC terminals can provide limited control of reactive power by means of Switching of filters and shunt banks and to some level by firing angle control. With PWM, VSC-HVDC offers the possibility to control both active and reactive power independently.
2. HVDC Light does not rely on the AC network's ability to keep the voltage and frequency stable. Independence of ac network makes it less sensitive for disturbances in the ac network and ac faults do not drastically affect the dc side.

3. Disturbances in the ac system may lead to commutation failures in classic HVDC system. As VSC-HVDC uses self-commutating semiconductor devices, the risk of commutation failure is significantly reduced.
4. The control systems on rectifier and inverter side operate independently of each other. They do not depend on a telecommunication connection. This improves the speed and the reliability of the controller.
5. The VSC converter is able to create its own ac voltage at any predetermined frequency, without the need for rotating machines. HVDC Light can feed load into a passive network.

III. CONCEPT OF INDUCTIVE FILTERING

A voltage source inductive filtering converter (VSIFC) for HVDC –Light transmission system, mainly composed of the inductive filtering (IF) transformer and the related full tuned (FT) branches with the commutating function for the self commutated converter. In the recent years with the technical developments of self commutated power electronic devices, Voltage source converter (VSC) –based systems arouse more and more attention .Due to the application of Pulse width modulation (PWM) technology in the control system for the self commutated converter valve set, the VSC represents good P & Q operating characteristics and it can independently control the active and reactive power which makes VSC-based HVDC system advantages to the fields of interconnected power systems.

The new HVDC transmission system adopts the new converter transformer and the corresponding inductive filtering technology. It tries to suppress the main characteristic harmonic currents at the secondary not the primary side of the converter transformer, which is complete different from the traditional passive filtering technology. In this way, it can efficiently suppress the flow path of the main characteristic harmonic currents in the new converter transformer and fundamentally solve the bad effects of the harmonic currents on the converter transformer.

As we know ,in the HVDC system the converter is the main harmonic resource .For the non linearity of the power electronics that converter represents ,it inevitably generates kinds of the characteristics and the non characteristics harmonic currents and voltages at the AC and the DC side of the HVDC system. In traditional HVDC ,all the generated harmonic currents flow into the grid side through the traditional converter transformer which means that the harmonic currents freely flow in the valve and the grid winding of the converter transformer ,but the traditional ac passive filter at the grid side cannot suppress them at all. With the use of inductive filtering method, it can suppress the harmonic current on the primary side and there is only few harmonic currents in the grid winding, thus it can reduce the negative effects of the harmonic currents on the converter transformer.

a) Inductive filtering method

In VSIFC –based HVDC Light system, the inductive filtering method is used to suppress the high order harmonic components that PWM technology cannot eliminate and these harmonic orders have been shown through below equations

$$f_n = k_1 f_c \pm k_2 f_r \quad (1)$$

Where

f_c = carrier frequency ,

f_r = modulation frequency ,

k_1 & k_2 are the coefficients that satisfy the following relationship.

When $k_1=1, 3, 5, \dots$

$$k_2 = 3(2m - 1) \pm 1 \text{ Where } m=1, 2, 3, \dots \quad (2)$$

When $k_1= 2, 4, 6, \dots$

$$k_2 = \begin{cases} 6m + 1, & m = 0,1,2 \dots \\ 6m - 1, & m = 1,2,3 \dots \end{cases} \quad (3)$$

Figure 1 show the single phase model of the new converter transformer which is used to analyze the inductive filtering mechanism. In this figure it indicates the harmonic current source, which is also the harmonic current of the secondary prolonged winding. I_{h1} & I_{h3} indicate the harmonic current of the primary winding and the secondary common winding respectively.

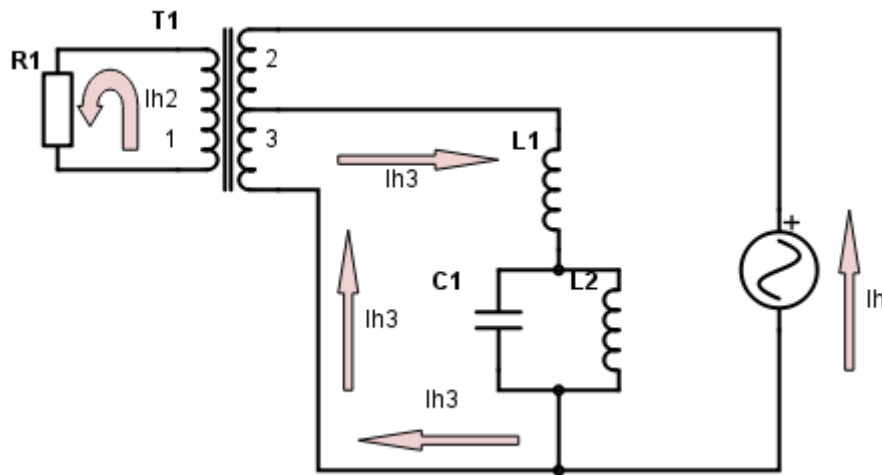

Fig.1: Single Phase Harmonic Model

According to magnetic force balance

$$W_2 I_h = W_3 I_{h3} + W_1 I_{h2} \quad (4)$$

In which W_1 , W_2 and W_3 are the number of turn of the primary winding, the secondary prolonged winding and the common winding respectively. If the harmonic ampere turns of the secondary prolonged winding and those of the common winding can keep balance then $I_{h1}=0$. That is there will be no induction harmonic current in the primary winding. That is to say, the harmonic current only flows in the secondary winding of the new transformer.

To realize the inductive filtering method, it not only needs the full tuning design of the tapping filter but also needs the zero inductance design of the secondary common winding of the new converter transformer.

IV. SPECIFIC REQUIREMENTS ON HVDC CONVERTER TRANSFORMER

The converter transformer is an integral part of an HVDC system. High AC and DC voltages put specific requirements on the dielectric insulation. Non sinusoidal currents give rise to additional losses which are to be considered. Like normal power transformers the operating losses can be split into two parts, no load loss and load losses. The no load loss is function of the applied AC voltage and the load losses depend on the load current.

As the applied AC voltage in converter operation is governed by the line side voltage and close to a sinusoidal shape the no load loss will remain the same as for a normal power transformer. The load losses are from the point of view of analyses divided into two components, one the so called RI^2 loss and the other the stray loss. The RI^2 loss is the loss component obtained as the product of the square of the load current, RMS value and the winding resistance measured by DC current. The leakage flux from the load current will create circulating currents in the windings and other metallic parts exposed to the leakage flux. These currents give rise to the so called stray losses in addition to the losses derived from the product of winding resistance and the square of the value of the load current. The voltages driving the circulating currents depend on the rate of change in winding current and thus the leakage flux. With a more or less stepwise change in load current during the commutation from one valve to another the induced voltages will be fairly high and as a consequence rms there is an increase in stray losses compared to the sinusoidal currents in a conventional power transformer.

V. SIMULINK MODEL AND RESULTS

The MATLAB simulation model of VSIFC-HVDC transmission system is shown in the Fig.2. In this model a filter is connected in the secondary side of converter transformer. In inductive filtering it tries to suppress the main harmonic characteristic harmonic current at the secondary side not the primary side of the converter transformer which is completely different from the traditional passive filtering. In this way, it can efficiently suppress the flow path of the main characteristic harmonic currents in the new converter transformer and fundamentally solve the bad effects of the harmonic currents on the converter transformer. Because the winding of the new converter transformer is different from the traditional one.

The development of VSC in last decade generated tremendous research interest in its power system applications. The VSC-HVDC uses the IGBTs and SPWM, which makes it possible to control the magnitude and phase angle of the converter AC output voltage. This flexibility of control allows for a number of advantages of VSC-HVDC. In order to fully utilize the capability of the VSC-HVDC, two control algorithms of the VSC-HVDC are investigated and the performance is tested under different situations. The vector control strategies which control active power, AC voltage/reactive power and DC voltage, are presented and evaluated for the VSC-HVDC transmission system which connects two weak AC grids. The results for control technique show that the system response is fast, high quality AC voltages and currents can be obtained and the active and reactive power can be controlled precisely.

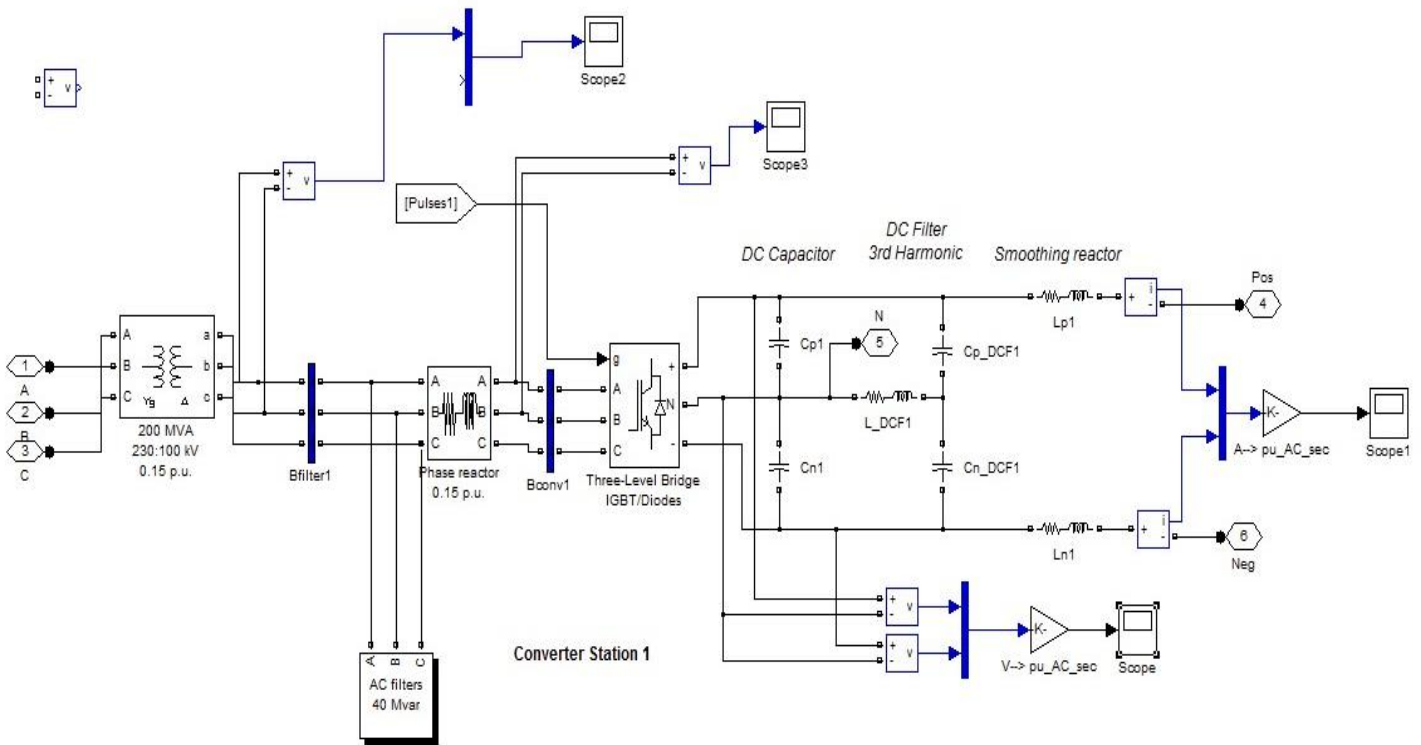

Fig. 2: Simulation Model of VSIFC-HVDC Transmission System

As for the proposed VSIFC it also satisfies the basic VSC operating equations. The main difference between traditional VSC and VSIFC is that reactance. As for traditional VSC, reactance can be determined easily, because it is leakage reactance of coupling transformer or the commutating reactor. However as for the VSIFC, the reactance is determined by the leakage reactance of the Inductive Filter Transformer and the fundamental impedance of the filter. Furthermore, such equivalent commutating reactance can influence the converter operating characteristic.

Comparative results of VSC HVDC and VSIFC HVDC are shown below

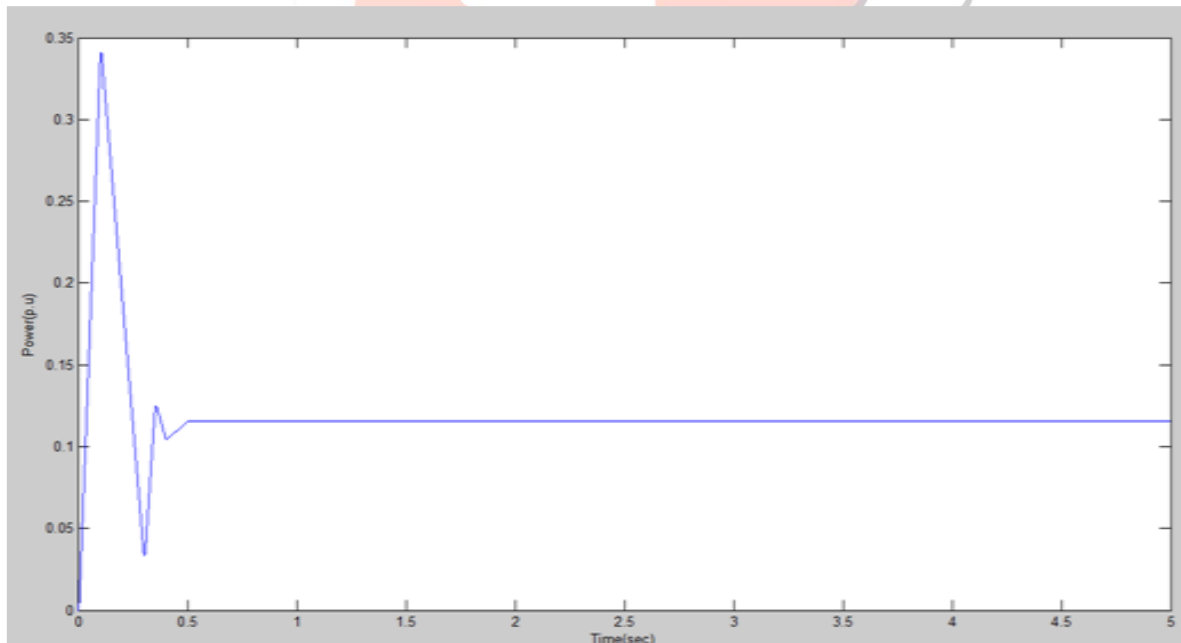

Fig. 3: Output Waveform of Power flow of Conventional VSC HVDC without Inductive Filtering

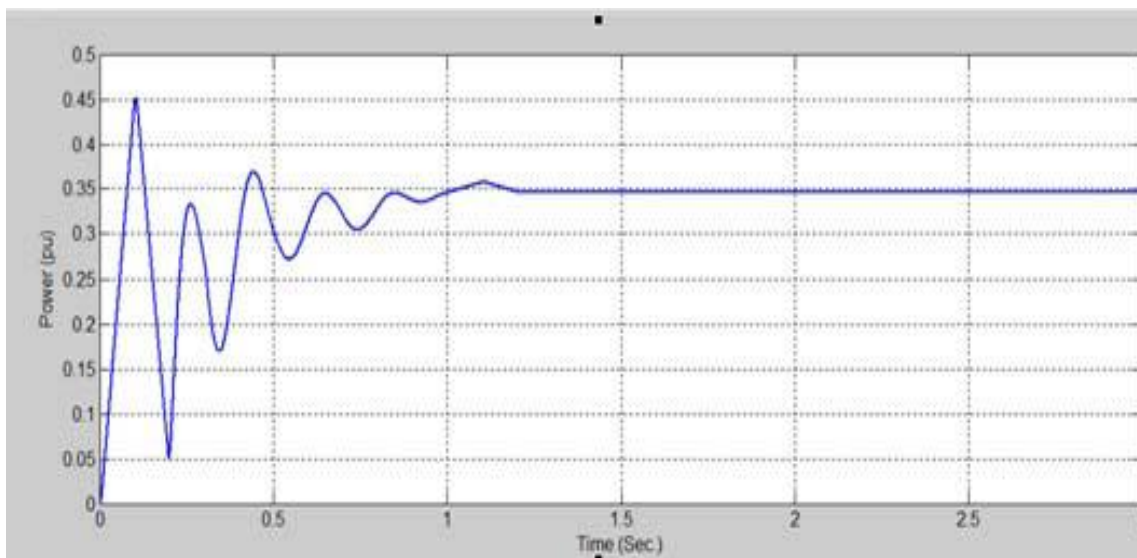

Fig. 4: Output Waveform of Power flow of VSIFC HVDC system-1 to system-2 with Inductive Filtering

VI. CONCLUSION

New Voltage source Inductive filtering converter based HVDC light system consist of Inductive filter i.e. I.F and F.T branches. Here test system is developed in MATLAB /SIMULINK environment, the typical operating characteristics have been simulated and characteristics of active power have been performed. The result indicates that the VSIFC –HVDC system can suppress the higher order harmonics not to flow into the grid winding of the transformer and meanwhile it can implement the bi-direction power flow control with the high transmitted power. Adopting the new converter transformer and the corresponding inductive filtering method can optimize the structure of HVDC transmission system, greatly reducing the negative effect of harmonic on the operation of transformer. There are some advantages of Inductive filtering like 1) harmonic suppression near by the harmonic resource.2) Reactive power compensation nearby the reactive power absorber.3) A new converter transformer is material saving.

REFERENCES

- [1] N. Flourentzou, V. Agelidis, and G. Demetriades, "VSC-Based HVDC Power Transmission Systems: An Overview," IEEE Trans. Power Electronics, vol. 24, no.3, pp. 592-602, Mar. 2009.
- [2] C. Du, E. Agneholm, and G. Olsson, "VSC-HVDC System for Industrial Plants With Onsite Generators," IEEE Trans. Power Delivery, vol. 24, no.3, pp. 1359-1366, Jul. 2009.
- [3] ABB Technical Reports, "It's time to connect-technical description of HVDC Light technology", Mar. 2008.
- [4] J. Forrest and B. Allard, "Thermal problems caused by harmonic frequency leakage fluxes in three-phase, three-winding converter transformers," IEEE Trans. Power Delivery, vol. 19, no.1, pp. 208-213, Jan. 2004.
- [5] Longfu Luo, Yong Li, Jiazhu Xu, Ji Li, Bo Hu, and Fusheng Liu, "A New Converter Transformer and a Corresponding Inductive Filtering Method for HVDC Transmission System," IEEE Trans. Power Delivery, vol. 23, no.3, pp. 1426-1431, Jul. 2008.
- [6] W. Long and S. Nilsson "HVDC transmission yesterday and today," IEEE Power & Energy, vol.5, No.2, March/April 2007.