

# A PREDICTIVE CONTROL WITH DUAL INPUT AND DUAL OUTPUT INDIRECT MATRIX CONVERTER

<sup>1</sup>SANDEEP KUMAR, <sup>2</sup>Er. DHARMENDRA SINGH

<sup>1</sup>SHEPHERD INSTITUTE OF ENGINEERING AND TECHNOLOGY, (SHUATS) ALLAHABAD  
<sup>2</sup>SAM HIGGINBOTTOM UNIVERSITY OF AGRICULTURE, TECHNOLOGY AND SCIENCES

**Abstract:** Based on the traditional indirect matrix converter topology dual input dual output indirect matrix converter is proposed, but the conventional six-switch inverter, used in the single-output indirect matrix converter, is replaced by a nine-switch dual output converter. The matrix converter has several advantages over traditional rectifier-inverter type power frequency converters. It provides sinusoidal input and output waveforms, with minimal higher order harmonics and no sub harmonics. Model Predictive Control (MPC) uses the discrete-time model of the system to predict future value of the controlled variable for all possible control actions and user-defined cost function related to control objectives is solved to find its minimum. The matrix converter providing directly AC-AC power conversion is one of the most interesting members of the power converter family. The control action which minimizes the cost function is selected and applied to the system for the next time interval. This paper presents a finite control set model predictive control strategy for a dual-input dual-output indirect matrix converter.

## I. INTRODUCTION

The dual input matrix converter is a converter, that consists of two input AC sources, nine voltage source converters (NVSC), Current source inverter, and Diode and foil capacitor. The matrix converter can be classified into two types and it depends upon the semiconducting stage. They are: 1) Indirect Dual matrix converter; 2) Direct Dual matrix converter. The Indirect Direct Matrix Converter (IMC) is the two-stage ac-ac power converter and it can convert ac source to ac load without a dc-link capacitor or other storage components. This significantly improves overall system reliability by eliminating failure-prone dc-link electrolytic capacitor. Dual output indirect matrix converter is based on the traditional IMC topology but the conventional six-switch inverter is replaced by a nine-switch inverter. This topology can produce two sets of three phase ac loads since nine switch inverter is a dual output inverter. Many matrix converter topologies have been proposed, mostly of the single-output type. In many applications, like electric traction and elevators, two or more ac loads need to be controlled independently. Single output type matrix converters can be used, but multiple converter - one for each output - are required. An alternative is to use multi-output matrix converter, with saving in terms of total number of switches .

The dual-output indirect matrix converter, shown in Fig. 1, uses four-quadrant switches in Current Source Rectifier (CSR) stage and has no dc-link capacitor. The rectifier stage is connected to the Nine-Switch Inverter (NSI) stage.

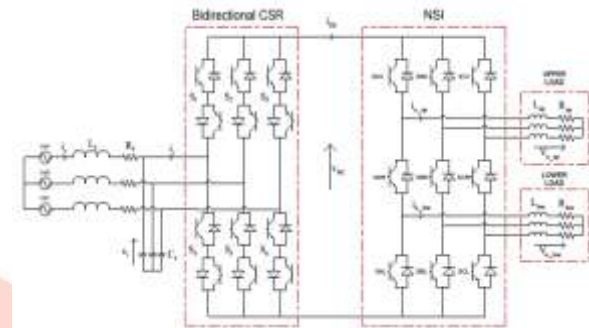

Figure 1. Dual-Output Indirect Matrix Converter Topology

Finite States Model Predictive Control (FS-MPC) is an optimization based control approach that minimizes a cost function to optimize system behavior. This paper presents an application of predictive control in indirect matrix converters. The switching state is selected by minimizing a quality function that considers the instantaneous reactive power in the input, the current error in the output, and the generation of a positive voltage in the dc link. MPC uses discrete-time model of the power converters to predict the future behavior of the control variables and solves a cost function to determine optimum control action. The control action that minimizes the cost function is selected and applied to the system for the next time interval. Different control objectives can be introduced in the cost function and controlled simultaneously by solving a single multi-objective cost function. Implementation of model predictive control technique is easy. In this paper, a model predictive control scheme is proposed for dual-output indirect matrix converter. Different control objectives, like output load current control and minimization of the instantaneous reactive power, are considered and performance of MPC is investigated.

## II. SYSTEM MODEL

The rectifier stage includes input filter to eliminate the high frequency component of the input currents and prevent the over voltages. For proper operation the rectifier must provide a positive dc-link

voltage to the Nine-Switch Inverter. The rectifier has 9 different switching states and the input voltage is defined as

$$V_i = [V_{ia} \ V_{ib} \ V_{ic}]^T \quad (1)$$

The relationship between positive dc voltage and input voltages is given by

$$V_{DC} = [S_1 - S_4 \ S_2 - S_5 \ S_3 - S_6] V_i \quad (2)$$

The input current vector of the rectifier is defined as

$$i_i = [i_{ia} \ i_{ib} \ i_{ic}]^T \quad (3)$$

current and dclink link current is

$$i_i = \begin{bmatrix} S_1 - S_4 \\ S_2 - S_5 \\ S_3 - S_6 \end{bmatrix} i_{DC} \quad (4)$$

For the NSI topology, each leg has three switches and there are eight different ON-OFF positions. All switches on the same leg cannot be turned on at the same time to avoid DC bus short circuit. Another switching restriction is that at least two switches on the same leg should be on, so that floating of the connected load is avoided. Considering these switching restrictions, each leg can be in three different switch combinations which are called {1, 0, -1}. Possible switch positions are illustrated in Table I with i= A, B and C identifying the inverter leg. The NSI has 27 possible switching states, but, since some of them are redundant, only 15 of these switching states are sufficient to control two ac loads independently.

**Table I**  
**Switches Positions of Legs**

	$S_i = 1$	$S_i = 0$	$S_i = -1$
$S_{Au}$	ON	OFF	ON
$S_{Bu}$	OFF	ON	ON
$S_{Cu}$	ON	ON	OFF

The instantaneous transfer matrix of upper load TU is defined as

$$T_U = [S_{AU} \ S_{BU} \ S_{CU}] \quad (5)$$

The relationship between output upper load voltage and the dc-link voltage is given by

$$V_{o-up} = \frac{V_{DC}}{3} \begin{bmatrix} 2 & -1 & -1 \\ -1 & 2 & -1 \\ -1 & -1 & 2 \end{bmatrix} T_U^T \quad (6)$$

The instantaneous transfer matrix of lower load TL is defined as

$$T_L = [1 - S_{AL} \ 1 - S_{BL} \ 1 - S_{CL}] \quad (7)$$

The relationship between output lower load voltage and the dc-link voltage is given by

$$V_{o-low} = \frac{V_{DC}}{3} \begin{bmatrix} 2 & -1 & -1 \\ -1 & 2 & -1 \\ -1 & -1 & 2 \end{bmatrix} T_L^T \quad (8)$$

The dc-link current is defined as in (9).

$$i_{DC} = T_U \begin{bmatrix} i_{oa-up} \\ i_{ob-up} \\ i_{oc-up} \end{bmatrix} + T_L \begin{bmatrix} i_{oa-low} \\ i_{ob-low} \\ i_{oc-low} \end{bmatrix} \quad (9)$$

In this work, an RL circuit is used as load model for upper load and lower load. Therefore, the continuous-time model of RL load is

$$V_o = R i_o + L \frac{di_o}{dt} \quad (10)$$

where R is the load resistance and L is the load inductance. The dynamic model of the second order input filter can be expressed as

$$V_s = L_f \frac{di_s}{dt} + R_f i_s + V_i \quad (11)$$

$$i_s = i_i + C_f \frac{dV_i}{dt} \quad (12)$$

### III. DISCRETE-TIME PREDICTION MODEL

Model Predictive Control uses a discrete-time model of the system to calculate future value of the controlled quantities. In order to obtain the discretetime model of the upper load and lower load, the forward Euler approximation is used

$$\frac{di_o}{dt} \approx \frac{i_o(k+1) - i_o(k)}{TS} \quad (13)$$

Output load current prediction equations are obtained using continuous-time model of the RL circuit (10) and forward Euler approximation (13). Future values of the upper load and lowerload currents are given in (14) and (15).

$$i_{oa-up}(k+1) = \frac{TS}{L_{up}} V_{o-up}(k) + i_{o-up}(k) \left( 1 - \frac{R_{up} TS}{L_{up}} \right) \quad (14)$$

$$i_{oa-low}(k+1) = \frac{TS}{L_{low}} V_{o-low}(k) + i_{o-low}(k) \left( 1 - \frac{R_{low} TS}{L_{low}} \right) \quad (15)$$

The second order input filter can be represented by a state-space model based on (11)-(12)

$$\begin{bmatrix} \dot{V}_i \\ \dot{i}_s \end{bmatrix} = A_C \begin{bmatrix} V_i \\ i_s \end{bmatrix} + B_C \begin{bmatrix} V_s \\ i_i \end{bmatrix} \quad (16)$$

Discrete-time state space model of input filter can be derived using continuous-time model. Considering a sampling time Ts, the discrete-time model of input filter can be expressed as follows,

$$\begin{bmatrix} V_i(k+1) \\ i_s(k+1) \end{bmatrix} = \Phi \begin{bmatrix} V_i(k) \\ i_s(k) \end{bmatrix} + \Gamma \begin{bmatrix} V_s(k) \\ i_i(k) \end{bmatrix} \quad (17)$$

The source current prediction equation is defined as

$$i_i(k+1) = \Phi(2,2) i_s(k) + \Phi(2,1) V_i(k) + \Gamma(2,1) V_s(k) + \Gamma(2,2) i_i(k) \quad (18)$$

Instantaneous reactive power can be calculated using discrete-time model of input filter model.

Reactive power is defined as

$$Q(k+1) = V_{s\beta}(k+1) i_{s\alpha}(k+1) - V_{s\alpha}(k+1) i_{s\beta}(k+1) \quad (19)$$

Input reactive power is expressed in  $\alpha$ - $\beta$  frame and Park transformation can be used to calculate real and imaginary parts of the associated vectors.

### IV. MPC SCHEME FOR DUAL OUTPUT INDIRECT MATRIX CONVERTER

Model Predictive Control strategy is based on the idea that the model of the system is used to predict the future value of the controlled quantities for each possible switching states, so that appropriate switching state that meets the desired control objectives can be identified. In this work, there are three control objectives: upper load current control, lower load current control and minimization of the instantaneous reactive power. Upper and lower load current tracking terms are defined as in (20) and (21).

$$g_1 = \sqrt{|i_{o\alpha-up}^* - i_{o\alpha-up}|^2 + |i_{o\beta-up}^* - i_{o\beta-up}|^2} \quad (20)$$

$$g_2 = \sqrt{|i_{o\alpha-low}^* - i_{o\alpha-low}|^2 + |i_{o\beta-low}^* - i_{o\beta-low}|^2} \quad (21)$$

The reactive power term is expressed as

$$g_3 = |Q^* - Q| \quad (22)$$

For reactive power minimization, reference reactive power  $Q^*$  is set to zero. The cost function for this system contains all these three error terms and it is defined as

$$g = A g_1 + B g_2 + C g_3 \quad (23)$$

Predictive control scheme is shown in Fig. 2 and reference values for load currents and reactive power are denoted by superscript “\*”. Constants A, B and C are the weighting factors. Three phase load currents are calculated in  $\alpha$ - $\beta$  frame and costs for the two ac load current errors are evaluated in this frame. Producing a positive dc-link voltage is necessary for the operation of the NSI stage. The State Elimination process is responsible for selecting rectifier switching states that provide positive dc-link voltage. As a result, only rectifier switching states that produce positive dc-link voltage are used to calculate future load currents.

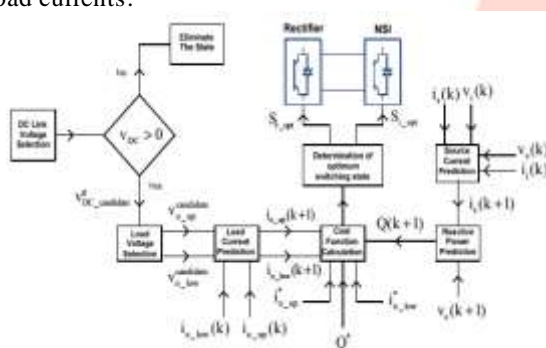

Figure 2. Model Predictive Control Scheme for Dual Output Indirect Matrix Converter  
**Dual Input Matrix Converter (DIMC)**

In the proposed dual input matrix converter, the conversion pattern takes place in two sections, first to convert AC to DC by using a nine voltage source converter (NVSC) or matrix converter section and then another conversion takes place by using an inverter to convert DC to AC. For given two input sources is not possible to give an directly AC to the grid side that's why by using an inverter to converting DC to AC. By using an foil capacitor and clamp circuit, the DC voltage can be stored and another on thing is the input frequency is lesser than the output frequency so the dual input matrix converter having an boosting capability and Accurate pure sinusoidal output voltage and input current and Figure3.shows an dual input matrix converter [DIMC] instead of nine voltage source converter [NVSC] and Current source inverter [CSI].

The matrix converter has several advantages over traditional rectifier-inverter type power frequency converters. It provides sinusoidal input and

output waveforms, with minimal higher order harmonics and no sub harmonics; it has inherent bi-directional energy flow capability; the input power factor can be fully controlled.

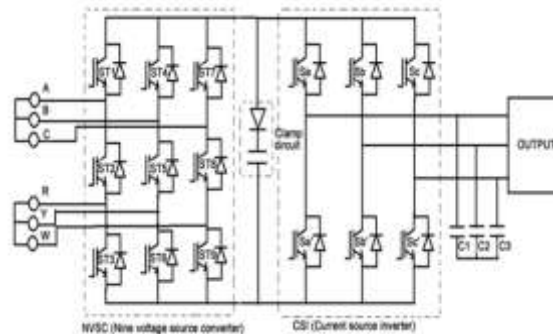

Figure.3 dual input Indirect Matrix Converter  
Topology

The main feature of this device is to convert the magnitude as well as the frequency of the input into a desired magnitude and frequency of the output with an “all-silicon” solution. Mainly, a Matrix Converter consists of nine bi-directional switches, which are required to be commutated and sequence in order to minimize losses and produce the desired output with a high quality input and output waveforms.

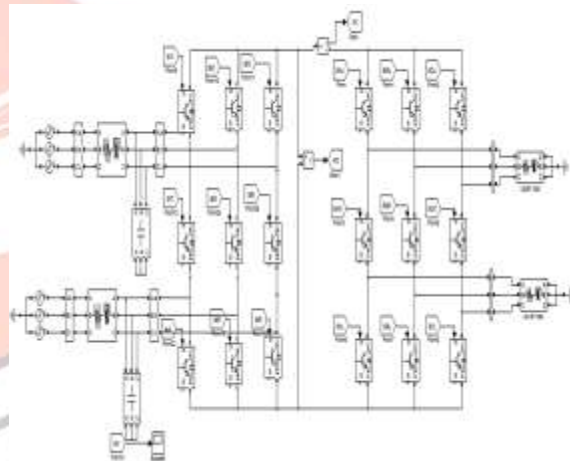

Figure 4. Block diagram of simulation with dual input and dual output

Applications areas of power converters still improvements in semiconductor technology, which order higher voltage and current ratings as well as better switching characteristics.

- The dual input matrix converter is a converter, that consists of two input AC sources, nine voltage source converters (NVSC), Current source inverter, and Diode and foil capacitor.
- The circuit operation of Dual input matrix converter directly consists of operation AC-DC-AC because here using two input AC sources, so bidirectional switch is not possible to get an output from another direction of switch.
- The matrix converter can be classified into two types and it depends upon the semiconducting stage.

- They are: 1) Indirect Dual matrix converter; 2) Direct Dual matrix converter.

**V. SIMULATION RESULTS**

The Dual Output Indirect Matrix Converter was simulated using MATLAB Simulink. Simulation parameters are listed in Table II.

**Table II**  
**Simulation Parameters**

$T_s$	20 $\mu$ s
Source Voltage	220 V peak/ 60 Hz
RL load	10 $\Omega$ / 30mH
Upper Load Current Reference	4 A/ 120 Hz
Lower Load Current Reference	7 A/30 Hz
$R_f$	0.5 $\Omega$
$L_f$	145 $\mu$ H
$C_f$	32 $\mu$ F

Upper load currents, lower load currents and source current are shown in Fig. 5. In Fig. 5, source voltage for only one phase is shown. According to simulation results, good output load current tracking is obtained.

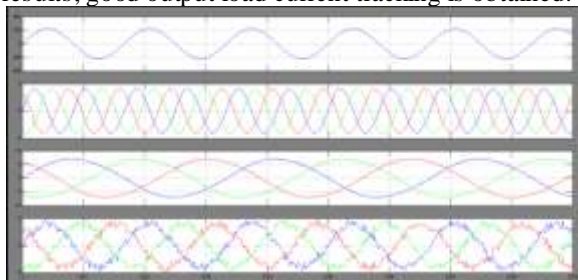

Figure 5. Source Voltage (top), Upper and Lower Load currents (middle), Source current (bottom)

Upper load current THD is 2.37% and lower load current THD is 2.23%. Minimization of the instantaneous reactive power is achieved and source current THD is 21.73%. In order to evaluate dynamic behavior of the predictive control technique, the system step response is shown in Fig. 6.

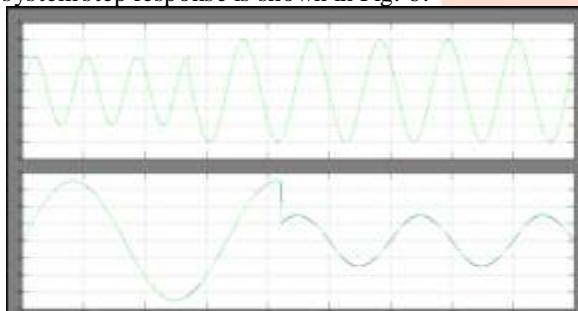

Figure 6. Step response of the predictive controller

Model predictive control technique is able control two ac loads even when their frequencies and magnitudes are different. Two ac loads are controlled independently by solving single multi-objective cost function.

The proposed method always provides positive dc-link voltage.

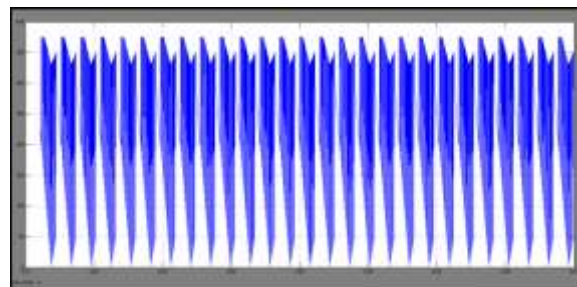

Figure 7. DC-Link Voltage

Fig.7 shows that dc-link voltage is always positive.

The State Elimination process in the control scheme always provides positive dc-link voltage, which is important for proper operation. The main idea of the state elimination process is that switching combinations of the rectifier stage that generate a negative dc-link voltage are eliminated and future load current for upper load and lower load are calculated using only proper switching combination of the rectifier stage

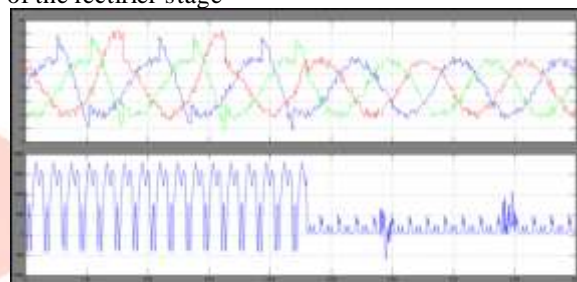

Figure 8. Source Current (top) and Instantaneous Reactive Power (bottom)

Fig.8 shows source current and instantaneous reactive power both with reactive power control and without reactive power control. Weighting factor C is initially set at zero so that reactive power is not controlled.

**VI CONCLUSION**

In this paper proposes a new model predictive control with dual input dual output indirect matrix converter. This control scheme uses a discrete-time model of the converter and predicts load current and reactive power to determine the best suited switching combination by solving a multi-objective optimization problem. Model predictive control technique provides fast dynamic response and good steady-state behavior. Model Predictive Control technique is tested for different control objectives and it performs well under the different conditions. Simulation results show that good system performance was obtained with predictive control scheme in steady state and under transient conditions. The main advantage of the predictive control approach is easy implementation and flexibility. This paper presents a finite control set model predictive control strategy for a dual-input dual-output indirect matrix converter. By using the simulation results the proposed method is analyzed.

**. REFERENCES**

- [1] Rodriguez J., Rivera M., Kolar J., Wheeler P., "A Review of Control and Modulation Methods for Matrix Converters", IEEE Transactions on Industrial Electronics, Vol. 59, No. 1, January 2012
- [2] Kolar J., Friedli T., Rodriguez J., Wheeler P., "Review of Three-Phase PWM AC-AC Converter Topologies", IEEE Transactions on Industrial Electronics, Vol. 58, No. 11, November 2011
- [3] Dehghan S.M., Yazdian A., "Hybrid Electrical Vehicle Based on Bidirectional Z-Source Nine Switch Inverter", IEEE Transactions on Vehicular Technology, Vol. 59, No. 6, July 2010
- [4] Liu X., Wang P., Loh P.C., Blaabjerg F., "A Compact Three-Phase Single-Input/Dual-Output Matrix Converter", IEEE Transaction on Industrial Electronics, Vol. 59, No. 1, January 2012
- [5] Nguyen T., Lee H., "Modulation Strategies to Reduce Common-Mode Voltage for Indirect Matrix Converters", IEEE Transactions on Industrial Electronics, Vol. 59, No. 1, January 2012
- [6] Rodriguez J., Kazmierkowski M.P., Espinoza J.R., Abu-Rub H., Young H.A., Rojas C.A., "State of the Art of Finite Control Set Model Predictive Control in Power Electronics", IEEE Transactions on Industrial Informatics, Vol. 9, No. 2, 2013
- [7] Rodriguez J., Pontt J., Silva C., Correa P., Lezana P., Cortes P., Ammann U., "Predictive Current Control of a Voltage Source Inverter", IEEE Transactions on Industrial Electronics, Vol. 54, No. 1, February 2007
- [8] Vargas R., Ammann U., Rodriguez J., "Predictive Approach to Increase Efficiency and Reduce Switching Losses on Matrix Converter", IEEE Transactions on Power Electronics, Vol. 24, No. 4, April 2009
- [9] Quevedo D., Aguilera R., Perez M., Cortes P., Lizana R., "Model Predictive Control of an AFE Rectifier with Figure 5. DC-Link Voltage Figure 6. Source Current (top) and Instantaneous Reactive Power (bottom) Dynamic References", IEEE Transactions on Power Electronics, Vol. 27, No. 7, July 2012
- [10] Dehghan M., Amiri A., Mohamadian M., Andersen M., "Modular space-vector pulse-width modulation for nine-switch converters", IET Power Electronics, pp. 1- 11, iet-pel.2012.0203
- [11] Dehghan M., Mohammadian M., Yazdian A., Ashrafzadeh F., "Space Vectors Modulation for Nine-Switch Converters", IEEE Transactions on Power Electronics, Vol. 25, No. 6, June 2010
- [12] Rivera M., Rojas C., Rodriguez J., Wheeler P., Wu B., Espinoza J., "Predictive Current Control with Input Filter Resonance Mitigation for a Direct Matrix Converter", IEEE Transactions on Power Electronics, Vol. 26, No 10, October 2011.