

Monitor the emergency situations using Tele health Radar System for Remote In-Door Fall Detection

¹N. Bhagya laxmi,

¹Assistant.professor,

¹ECE Department,

¹CMR College of Engineering And Technology,Hyderabad.

Abstract— the provision of healthcare remotely by means of telecommunications technology systems and applications are extensively investigated nowadays to enhance the quality of care and, to detect emergency situations and to monitor the well being of elderly people, allowing them to stay at home independently as long as possible. In this paper, an embedded Telehealth system for continuous, automatic, and remote monitoring of real-time fall emergencies is accessible. The system, consisting of a radar sensor and base station, represents a cost effectual and efficient healthcare solution. The implementation of the falt detection data processing technique, based on the least square sup-port vector machines, through a digital signal processor and the management of the communication between radar sensor and base station are detailed. Experimental tests, for a total of 65 mimicked fall incidents, recorded with 16 human subjects (14 men and two women) that have been monitored for 320 min, have been used to validate the proposed system under real situation. The subjects' weight is between 55 and 90 kg with heights between 1.65 and 1.82 m, while their age is between 25 and 39 years. The experimental results have shown a sensitivity to detect the fall events in real time of 100% without exposure false positives. The tests have been performed in an area where the radar's operation was not limited by practical situations, namely, signal power, coverage of the antennas, and presence of obstacles between the subject and the antennas, To prevent this situation we as to use the tracking system to using in indoor system.

Index Terms— GSM,Contactless, DSP platform, fall detection, health monitoring, least-square support vector machines (LS-SVM), movement classification, radar remote sensing, telehealth systems, Zigbee communication.

I. Introduction

The elderly population has been progressively increasing worldwide. This situation, together with the shortage of nursing homes and the natural desire to stay at home, has resulted in a growing need for healthcare solutions to improve the quality of life for senior citizens and to increase the efficiency of systems for health and social care. Elderly people who live alone are usually exposed to health risks which in some cases may cause casualty. Moreover, in addition to chronic health problems, fall incidents are considered one of the major problems among the elderly worldwide. They often result in serious physical and psychological consequences. The rapid detection of a fall event can reduce the transience risk and increase the chance to survive the incident and return to independent living. For that reason, it is imperative to detect falls as soon as they occur such that immediate assistance may be provided.

Current fall detection systems are based on a necklace or wristwatch with a button that is activated by the patient in case of an accident. Other devices involve accelerometers and gyroscopes attached to the body . However, in emergency situations, this imposes an important risk factor. In fact, the person may forget to wear the device, or likely may no longer be able to press the button. Moreover, these devices produce discomfort and false alarms. An academic investigation of an accelerometer based fall detector system using a biocompatible and impervious skin patch has been reported in . It can be carried by the user with the added value that the subject does not have to remember to wear it. The ideal solution is therefore a contactless approach that avoids the need for actions by the elderly person. Systems under investigation in the latter category are based on video cameras , floor vibration, and acoustic sensors . In the case of the video camera method, researchers are currently trying to address challenges related to low light, field of view, and image processing, but privacy is also a concern. Floor vibration and acoustic sensors have limited success due to the environmental interference and background noise .

The resulted system, combining radar, wireless communication, and data-processing techniques, was demonstrated in an indoor environment to detect fall emergencies and to localize persons without the need of radio frequency identification tags attached to the person . The system consists of a radar sensor that detects the monitoring signals of a person and transmits this information to a base station for remote data processing. The described base station consists of a Zigbee. If any injuries is affected to the persons and if they falls by checking of the fall detector and send s the information to the hospitality persons to send the message by using of GSM and Tracking the person where he as to fall by using of Radar system.

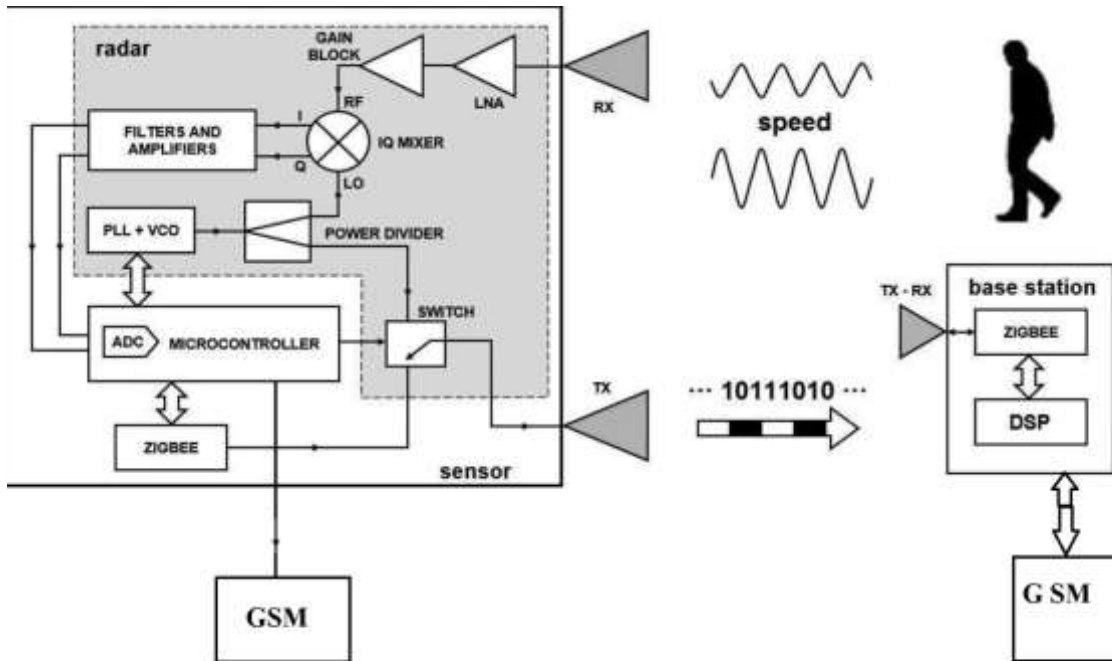

Fig. 1. Block diagram of the fall detection health system.

Module, a microcontroller, and laptop, resulting in a non compact and energy ineffective solution. Moreover, the system was not able to work in real time. In fact, the speed signals, consisting of one single activity (i.e., falling, walking) with known starting and end time points, were collected, stored, and processed.

A cost-effective and energy-efficient base station based on a DSP-embedded platform has been developed to detect fall emergencies in real time. The implementation of the data processing technique to operate in real time, the management of the communication between radar sensor and base station, together with design challenges, practical limitations, and their solutions, are presented and discussed.

II. FALL DETECTION TELEHEALTH SYSTEM

The telehealth system consists of a sensor, combining radar, computational, and wireless communication capabilities, and a base station for data processing (see Fig. 1). A continuous wave waveform at 5.8 GHz is generated and transmitted toward a human target to detect its speed produced during daily activities, such as falling, walking, random movements. In fact, by the Doppler Effect, a radio wave reflected by a moving target under-goes a frequency shift proportional to its velocity. The reflected echo, containing the person's speed information, is collected by the receiver. The resulting baseband signals are digitized and transmitted to the base station to distinguish fall events from normal movements.

Telehealth is a collection of means or methods for enhancing health care, public health, and health education delivery and support using telecommunications technologies. Telehealth encompasses a broad variety of technologies and tactics to deliver virtual medical, health, and education services.

The sensor architecture and the DSP-based base station are described in Sections II-A and II-B, respectively. Moreover, the technique to distinguish fall events from normal movements is described in Section II-C

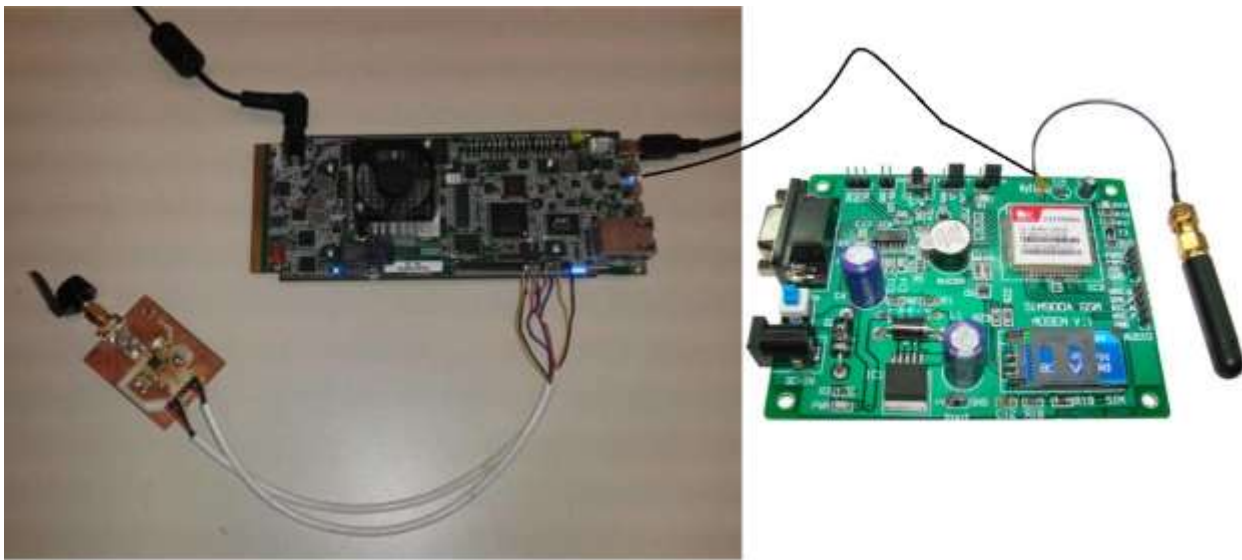

Fig. 2. Developed radar sensor.

A. Sensor Architecture

The radar sensor is composed of a radar module, a micro-controller, and a Zigbee module (see Fig. 2). It also mounts a two-element bow tie antenna to support both the wireless communication between the sensor and the base station and the radar working frequency. The antenna was optimized to reduce the backscattering and crosstalk effects, presenting a semispherical radiation pattern to cover a whole room. and send the msg using GSM module

The radar module integrates a fractional-N phase-locked loop (PLL), a power divider, a radio frequency (RF) switch, a low noise amplifier (LNA), a gain block, an in-phase and quadrature (IQ) mixer, baseband filters, and amplifiers.

The 5.8-GHz single tone is generated by the PLL that is configured by the microcontroller. This signal is sent to the power divider that splits it in two branches. The first output is connected to the RF switch. The latter is controlled by the microcontroller to alternatively connect the radar transmitter and the Zigbee module to the transmitter antenna. The signal reflected from the target is received, amplified, and then mixed with a copy of the transmitting signal. On the receiving path, the signal is amplified by the LNA and the gain block, for a total gain of 30 dB. The output of the gain stage is connected to the RF input of the mixer. The local oscillator input of the mixer is connected to the second output of the power divider. The IQ baseband signals produced by the mixer are amplified, filtered, and adapted to the ADC's dynamic range. The 10-bit ADC is integrated into the microcontroller and works with a sampling frequency of 250 Hz, such that every 4 ms an IQ sample pair is acquired and digitized. Since the Zigbee module transmits only frames organized in bytes, each IQ sample pair is mapped in 3 bytes. These samples are packed in a frame of 75 bytes and then transmitted wirelessly to the base station through the Zigbee module every 100 ms. This transmission requires about 3 ms

B. DSP-Based Base Station Architecture

The developed base station consists of a Zigbee module and the TMS320C6678 DSP platform. This processor implements a single instruction, multiple data approach in floating point instructions in single (32 bits) and double (64 bits) precision, allowing to maintain the same data format of Matlab scripts. It integrates eight DSP cores that run at 1 GHz each, and it has shared integrated static random access memory (SRAM) of 4 MB. It also has a high speed external memory controller, which supports DDR3 up to 1600 MT/s, together with a data bus width of 64 bits that is capable of 12.8 GB/s. For this particular DSP, mathematic and signal processing hand assembly optimized libraries are also available, to speed up the process of optimizing signal processing algorithms.

The DSP is connected through a serial peripheral interface (SPI) to the Zigbee IC. The latter acts as a slave in the SPI interface while the DSP is the master. There are also three control lines, namely, RST (active low reset), SLP (sleep), and IRQ (interrupt request). The latter is the interrupt pin that is set every time a complete frame is received. This pin is connected to a DSP general-purpose input/output port that triggers the routine for receiving the transmitted frame from the Zigbee module.

C. Data Processing Technique

In this Section, the technique to distinguish fall events from normal movements, is briefly introduced for completeness to understand how the system has been extended to work in real time. In fact, the speed signals, consisting of one single activity with known starting and end time points, were collected, stored, and processed offline later. Moreover, the corroboration was performed considering only falling and walking movements.

III. FALL DETECTOR

In this Section, the implementation of the data processing technique to operate in real time is detailed. In particular, the synchronization and the communication between radar sensor and base station are explained in Section III-A.

A. Sensor-Base Station Communication

In order to synchronize the system, the Zigbee modules of the sensor node and of the base station are set at power-on as receiver and transmitter, respectively. The sensor node will stay in this modality until it receives a frame of two fixed bytes (coins) from the base station, meaning that it is ready to process the monitoring signals. The base station sends the coins to the sensor. The latter checks whether the received bytes are equal to a copy of the coins saved in its memory. If that condition is verified, the sensor is changed immediately to transmission mode and it sends back the received coins to the base station that in the meanwhile has set itself as receiver. Once they have been received, the base station checks whether the received coins are equal to the initial token sent at the beginning of the synchronization process. In the case this procedure is correct, a message, meaning that the synchronization has been achieved, is printed out to the debug monitor. On the other hand, if this procedure is not correct or the coins are not received within 1 s,

IV. EXPERIMENTAL RESULTS

Experimental tests have been performed with human volunteers in a room of $5 \times 5 \text{ m}^2$. Furniture, a metal shelf, tables, a sofa, PCs, and chairs were positioned to mimic a real room setting. The sensor was fixed to the wall at a height of 1.25 m while the base station was positioned on a desk about 4 m away the sensor.

The classification model has been created on signals acquired on three volunteers in different positions in the room who did not participate in the testing phase. It includes 40 random walking activities, 30 activities of sitting down and standing up, 40 fall activities, considering both hard falls, where the person falls directly to the ground, and soft falls, by which the person tries to avoid the incident by grabbing objects. In addition, 20 random movements, such as opening the window, moving a chair, have been also considered. If the person is fall, in case of injured circumstances the system detects and send the information to hospitality member by using of the GSM.

In order to validate the real-time fall detector, 64 tests, for a total of 65 simulated fall events, have been performed on 16 volunteers (14 men and two women) that have been continuously monitored for 5 min each. This means that this validation considered 320 min of measurements. Therefore, considering that a segment of signal is processed every 100 ms and also the power-on condition (namely, the system should first accumulate 2 s of signals), this validation has been performed over 190 784 testing segments of radar signal. The subjects were allowed to move without restrictions within the antenna's beamwidth, meaning that they could mimic all the typical movements that are normally achieved in a domestic environment (i.e., walking, talking at the cellular while walking in the room, dropping object or even a chair, walking with a cane and with a walker, sweeping, working at the PC, watching films, resting on the sofa, eating, open windows, drinking water, etc.). One single volunteer was present in the room at a time and performed only one fall during the monitored period. Only in one test, the volunteer was invited to mimic two consecutive falls where the subject experiences a first fall, then tries to gets up, and then falls again. The mimicked fall incidents included both hard falls and soft falls. Other simulations consider situations where the person falls from a chair, loses the equilibrium while walking with a cane or with a walker, sits and misses the chair, loses the equilibrium and falls on a chair, is bent over and tries to get up. To this end, videos recorded in nursery homes with real fall incidents have been watched in order to mimic real life situations. The subjects' weight is between 55 and 90 kg with heights between 1.65 and 1.82 m, while their age is between 25 and 39. The experimental results have shown a sensitivity in detecting the mimicked fall events in real time of 100%. Moreover, no false positives have been reported.

It should be noted that this validation considers only falls where the volunteers are located at angles between 0° and about 45° from the line of sight of the antenna, otherwise the related radial speeds would produce lower Doppler frequencies such that fall incidents will be classified as normal movements. Other possible limitations of the radar system are when the person is in a position outside of the antenna beamwidth and when his/her reflection is obstructed by furniture. Also, the target absolute distance could represent a limitation. In fact, the longer the distance is, the weaker is the target's reflection, such that it may no longer lie within the radar dynamic range and then it will be buried in the noise. This problem can be mitigated both by increasing the output power and by increasing the receiver's gain. However, the maximum transmitted power is limited by the spectral masks of the standards (i.e., maximum allowable power in in-door environments), while the receiver's gain is limited by the unwanted reflections generated by the radar itself (i.e., crosstalk, backscattering, isolation between transmitter and receiver). However, the radar dynamic range does not represent a serious problem in a typical room of $5 \times 5 \text{ m}^2$. Obviously, these limitations could be avoided by using multiple sensors.

Fig. 10 shows the classification results on a small portion of a signal containing multiple random activities and a fall event invoked at about 58 s. Each dot represents the class where a segment of 2 s of signal has been assigned. The event was classified as fall for seven consecutive segments.

The measured time to process a segment of 2 s of signal is about 16 ms. This means that, considering Zigbee transmissions every 100 ms, with the developed approach, it is possible to process signals coming from six sensors without loss of information.

Since an alarm is activated when three consecutive segments are classified as a fall, the maximum time to detect the incident is about 316 ms.

Fig. 11(a) and (b) represents the resulting speed signals of a walking movement and of a fall event, respectively. The frequency of the signals is proportional to the radial velocity of the person during the movement. Fig. 11(c) and (d) shows the two spectrograms corresponding to the movement activities of Fig. 11(a) and (b), respectively. The horizontal axis represents time, the vertical axis frequency, a third dimension indicating the amplitude of a particular frequency at a particular time is represented by different shades of gray. In this example, a sliding window size of 64 samples with 50% overlap is adopted. In case of a fall, an increase in dominant frequency over time is

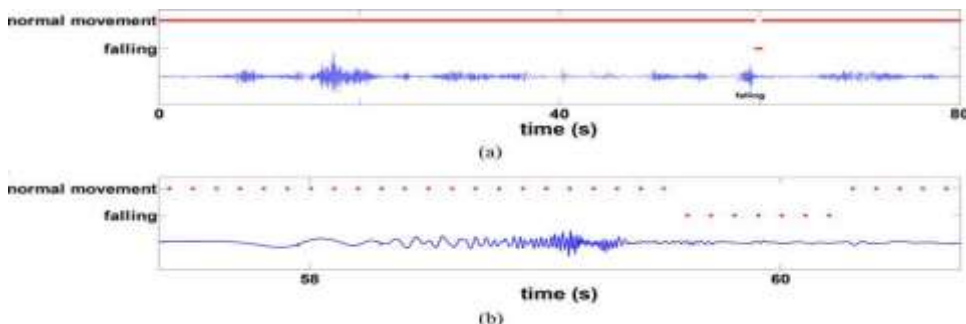

Fig. 10. Classification results (a) of a signal containing multiple activities and (b) zoom of the related fall event. In this example, the results of the classification are sent to Matlab for plotting.

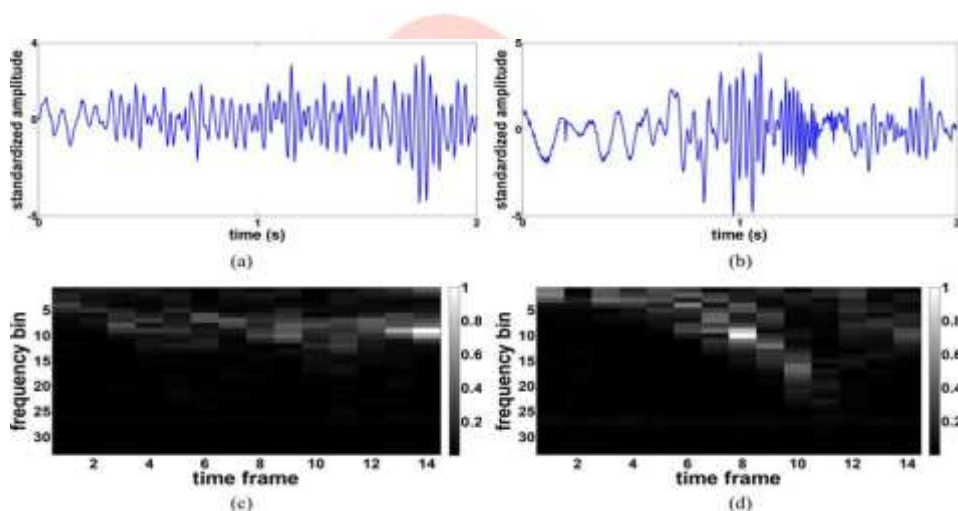

Fig. 11. Speed signal during (a) walking movement and during (b) fall event. Spectrograms corresponding (c) to the walking movement and (d) fall event.

V. CONCLUSION

In this paper, To monitor the emergency situation using a telehealth system care for elderly people both in home and clinical environment ,if they fall immediately the system send the information or message send to particular person relation member or doctor by using of GSM Module . a telehealth system aiming at remote fall detection in an in-door environment has been presented. It consists of a microwave radar sensor and a wirelessly connected base station for data processing. The implementation of the fall detection algorithm by means of a DSP platform has been presented. Experimental results conducted with human subjects under real circumstances have shown a sensitivity to detect fall events in real time of 100%, without reporting any false positives, with a maximum delay of about 316 ms. The tests have been performed in an area where the radar's operation was not limited by practical situations, namely, signal power, coverage of the antennas, and presence of obstacles between the subject and the antennas. Moreover, the proposed approach would allow to process at the same time up to six sensors without loss of information. This system is the result of the convergence of information, wire-less technologies, and radar techniques, and is in-line with the growing need for health technologies and applications to enhance the quality-of-care for elderly people both in home and clinical environment. Next step is to integrate multiple sensors in a wireless sensor network to detect fall incidents in all the directions and to perform in-door positioning by implementing a trilateration technique.

VI. REFERENCES

[1] Leroux, and D. Schreurs, "Analysis of an indoor biomedical radar-based system for health monitoring," *IEEE Trans. Microw. Theory Tech.*, vol. 61, no. 5, pp. 2061–2068, May 2013.

- [2] C. J. L. Murray and A. D. Lopez, "Global and regional descriptive epi-demiology of disability: Incidence, prevalence, health expectancies and years lived with disability," *Global Burden Dis.*, vol. 1, pp. 201–246, 1996.
- [3] E. Dejaeger, S. Boonen, J. Coussement, and K. Milisen, "Recurrent falling, osteoporosis and sarcopenia, three major problems, an integrated approach," *J. Gerontol. Geriatr.*, vol. 40, no. 6, pp. 262–269, Dec. 2009.
- [4] S. R. Lord, C. Sherrington, and H. B. Menz, *Falls in Older People: Risk Factors and Strategies for Prevention*. Cambridge, U.K.: Cambridge Univ., 2007.
- [5] T. Zhang, J. Wang, P. Liu, and J. Hou, "Fall detection by embedding an accelerometer in cellphone and using KFD algorithm," *Int. J. Comput. Sci. Netw. Security*, vol. 6, no. 10, pp. 227–284, Oct. 2006.
- [6] A. K. Bourke and G. M. Lyons, "A threshold-based detection algorithm using a bi-axial gyroscope sensor," *Med. Eng. Phys.*, vol. 30, no. 1, 84–90, Jan. 2006.
- [7] D. Naranjo-Hernandez, L. M. Roa, J. Reina-Tosina, and M. A. Estudillo-Valderrama, "Personalization and adaptation to the medium and context in a fall detection system," *IEEE Trans. Inform. Technol. Biomed.*, vol. 16, no. 2, pp. 264–271, Mar. 2012.
- [8] T. Lee and A. Mihailidis, "An intelligent emergency response system: Pre-liminary development and testing of automated fall detection," *J. Telemed. Telecare*, vol. 11, no. 4, pp. 194–198, 2005.
- [9] F. Wang, M. Skubic, C. Abbott, and J. M. Keller, "Body sway measurement for fall risk assessment using inexpensive webcams," in *Proc. 32nd Annu. Int. Conf. IEEE Eng. Med. Biol. Soc.*, 2010, pp. 252–255.
- [10] A. Edgcomb and F. Vahid, "Automated fall detection on privacy-enhanced video," in *Proc. 34th Annu. Int. Conf. IEEE Eng. Med. Biol. Soc.*, 2012, 252–255.
- [11] E. Auvinet, F. Multon, A. Saint-Arnaud, J. Rousseau, and J. Meunier, "Fall detection with multiple Cameras: An occlusion-resistant method based on 3-D silhouette vertical distribution," *IEEE Trans. Inform. Technol. Biomed.*, vol. 15, no. 2, pp. 290–300, Mar. 2011.
- [12] Y. Zigel, D. Litvak, and I. Gannot, "A method for automatic fall detection of elderly people using floor vibrations and sound—Proof of concept on human mimicking doll falls," *IEEE Trans. Biomed. Eng.*, vol. 56, no. 12, 2858–2867, Dec. 2009.
- [13] L. Yun, Z. Zhiling, M. Popescu, and K. C. Ho, "Acoustic fall detection using a circular microphone array," in *Proc. Annu. Int. Conf. IEEE Eng. Med. Biol. Soc.*, 2010, pp. 2242–2245.
- [14] M. Mercuri, D. Schreurs, and P. Leroux, "SFCW microwave radar for in-door fall detection," in *Proc. IEEE Topical Conf. Biomed. Wireless Technol.*, 2012, pp. 53–56.
- [15] P. Karsmakers, T. Croonenborghs, M. Mercuri, D. Schreurs, and Leroux, "Automatic in-door fall detection based on microwave radar measurements," in *Proc. Eur. Radar Conf.*, 2012, pp. 202–205.
- [16] Population Division of the Department of Economic and Social Affairs of the United Nations Secretariat. (2013). UN world population prospects. [Online]. Available: <http://esa.un.org/unpd/wpp/index.htm>.

Authors and Affiliations



N. Bhagya Laxmi Received her post graduation degree from Nova engineering college, Telangana, India and currently working as assistant professor in Department of Electronics and communication Engineering in CMR college of engineering and technology, Telangana, India