

A New Technique of Performance Improvement of STATCOM with Supercapacitor

¹Pranjali R. Nirvikar, ²Pratik Ghutke, ³Hari Kumar Naidu
¹M.Tech scholar, ²Assistant Professor, ³HoD Electrical Engineering
 TGPCET Mohgaon, Nagpur

Abstract: Recent advancement in Electric Energy Storage technologies provides an opportunity of using energy storage systems to address the issues of Grid-integrated wind energy conversion systems. This paper proposes a novel configuration of a Static Synchronous Compensator (STATCOM) with a supercapacitor-based short-term energy storage system for managing wind power intermittency during grid faults. Power quality problem causes a mis-operation or failure of end user equipments. Distribution network, sensitive industrial loads and critical commercial operations suffer from outages and service interruptions which can cost financial losses to both utility and consumers. In India the use of electronic loads is increasing very fast, the gap between demand and the supply have made the reliability and power quality a critical issue. There is continuous thrust on optimal utilization of the Non-conventional energy sources along with the central power station. In this paper a critical review have been presented chronologically various work to improve quality of power with the help of energy storage device i.e. Supercapacitors energy storage systems for ASD, elevators, UPS, and power distribution system, ride through capability, reactive power injection and real power injection for stabilization of the system.

Keywords: STATCOM, Supercapacitors Energy Storage System, reactive power, DC-DC converter, voltage stability.

I. INTRODUCTION

Nowadays the power system is in a process of undergoing from regulated market to deregulated, centralized to more localized system that are situated to near the load; the reason behind the increased concern for environment, to utilize renewable energy technologies, flexibility, lower initial investment costs, lower time of project completion, electricity market liberalization, developments in DG technology, constraints on the construction of new transmission lines, increased customer demand for highly reliable electricity. Further with the fast increase in electronic loads has made the quality of power supply a critical issue. Since the power distribution system must be able to supply the power reliably while maintaining the power quality throughout the year; so there is strong need of energy storage capability with the central power utility and also the non conventional energy resource.

The penetration of wind energy into power grids is also increasing significantly. The wind farms constructed with induction generators have poor fault ride-through capability; get tripped out during severe grid faults. The tripping of wind farms during a fault will exacerbate the situation and lead to system instability. It becomes necessary to require wind turbine generators (WTGs) to stay connected to the grid for reliable power system operation. An important issue to be addressed during fault is the intermittent power in the wind farm terminals, because it causes severe impact on wind power generation and power system balance. Several studies were carried out using the Static synchronous compensator (STATCOM) for fault ride-through of wind farms, but no proper investigation was done to handle the energy that the grid cannot absorb during severe fault. The only solution is to absorb the power using energy storage devices, but the storage device increases the expense of the compensation device greatly. In various economical energy storage techniques were investigated for handling intermittent power but their round-trip efficiency is very poor. Compared to other storage equipment, the supercapacitor bank is found to be a suitable energy storage system (ESS).

The supercapacitors have advantageous features like higher power density, higher round-trip efficiency, long life, and low cost per cycle. Since the energy density is low and self-discharge current is greater, it is suitable only for short-term power exchange. After supercapacitor-based ESS was used to deliver active power to the critical loads during fault and to improve power quality at a common connection point. The supercapacitor-based storage system was used to regulate and balance the power generated in wind farms. The new installations of wind farms are tending to use Wind energy conversion systems (WECSs). Nevertheless, a considerable percentage of Squirrel Cage Induction Generator (SCIG)-based wind farms are still in use. Hence, extensive investigation is required to provide a solution for intermittent power management of the SCIG-based wind farms. This paper presents a new configuration of a supercapacitor-aided ESS-based STATCOM for managing intermittent power and improving fault ride-through capability of a SCIG-based WECS. The supercapacitor used here is a dedicated ESS only to operate during grid fault and voltage variation. It utilizes a DC to DC converter to handle the intermittent power at wind farms during grid fault. MATLAB/SIMULINK is used to develop a grid-integrated wind farm model and to realize the proposed strategy.

II. SYSTEM OVERVIEW

1. STATCOM

A STATCOM is one of the famous and important members of the FACT family. It has a very special ability to absorb reactive power and provide reactive power, and again absorbing real power in and providing real power out of the system. The STATCOM is a shunt compensated device. The STATCOM can provide 3-phase controlled waves of various parameters like the phase angle, frequency, voltage magnitude etc. It is actually a kind of a solid state switching device which has the capability to generate and accept real power and reactive power independently. Here the STATCOM has the heart of the device is the VSI that is the voltage source inverter. A static capacitor is used to provide the constant dc voltage supply to the STATCOM's voltage source inverter. The STATCOM's outer terminal is connected through a leakage reactance to the system or the main voltage bus that is to be connected. And here we have the constant power of the dc voltage is being supplied by the chosen well designed capacitor which can give a constant dc voltage to the VSI terminal of the STATCOM. The unique ability of the STATCOM to absorb the reactive power and the real power when needed with the fast response makes it a special device.

2. DC/DC Converter model

The DC/DC converter presented in Figure 1d has two operation modes: Buck and Boost. By triggering insulated-gate bipolar transistors (IGBT) S1, the converter works in Buck mode and energy is transferred from the EPT low voltage side capacitor to the energy storage system. By triggering IGBT S2, the converter works in Boost mode and energy is transferred from the energy storage system to the EPT low voltage side capacitor. The dynamic model of the converter is presented as follows:

$$\begin{cases} L_{dc} \frac{di_{ldc}}{dt} = u_{pwm} - u_{sc} \\ C_{sc} \frac{du_{sc}}{dt} = i_{ldc} \end{cases}$$

Where, L_{dc} is the inductance of the inductor, C_{sc} is the capacitance of the super-capacitor stack, i_{ldc} is the current of the inductor, u_{sc} is the voltage of the super-capacitor stack, u_{pwm} is the voltage of IGBT S2.

3. Super Capacitor Energy Storage (SCES)

Supercapacitor is a double layer capacitor; the energy is stored by charge transfer at the boundary between electrode and electrolyte. The amount of stored energy is function of the available electrode and electrolyte surface, the size of the ions, and the level of the electrolyte decomposition voltage. Supercapacitors are constituted of two electrodes, a separator and an electrolyte. The two electrodes, made of activated carbon provide a high surface area part, defining so energy density of the component. On the electrodes, current collectors with a high conducting part assure the interface between the electrodes and the connections of the supercapacitor. The two electrodes are separated by a membrane, which allows the mobility of charged ions and forbids no electronic contact. The electrolyte supplies and conducts the ions from one electrode to the other. Usually supercapacitors are divided into two types: double-layer capacitors and electrochemical capacitors. The former depends on the mechanism of double layers, which is result of the separation of charges at interface between the electrode surface of active carbon or carbon fiber and electrolytic solution. Its capacitance is proportional to the specific surface areas of electrode material. The later depends on fast faraday redox reaction.

The electrochemical capacitors include metal oxide supercapacitors and conductive polymer supercapacitors. They all make use of the high reversible redox reaction occurring on electrodes surface or inside them to produce the capacitance concerning with electrode potential. Capacitance of them depends mainly on the utilization of active material of electrode. The working voltage of Electrochemical Capacitor is usually lower than 3 V. Based on high working voltage of electrolytic capacitor, the hybrid super-capacitor combines the anode of electrolytic capacitor with the cathode of electrochemical capacitor, so it has the best features with the high specific capacitance and high energy density of Electrochemical capacitor.

4. Gate driver circuit

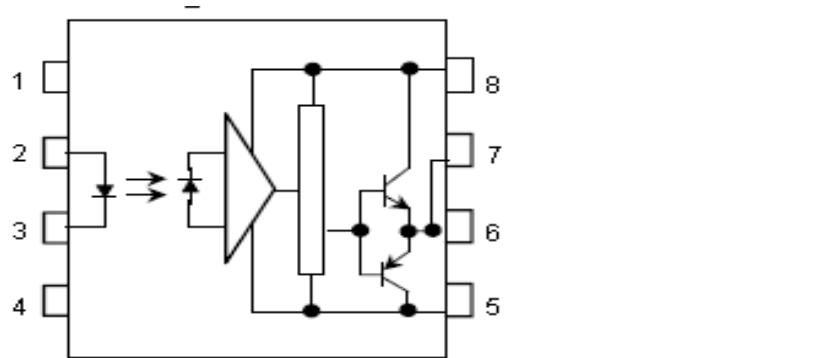

Figure 1: Pin diagram of the High side driver circuit TLP250

- 1: N.C, 2: Anode,
 3: Cathode, 4: N.C,
 5: GND, 6: V0 (output),
 7: V0 and 8: VCC.

As mentioned earlier, the main function of the gate driver circuit is to adapt the original low-power PWM signal to be an adequate signal that can turn on and off the IGBTs. Furthermore, by using Optocoupler as shown in the arrangement of the circuit in Figure1 the gate driver is not only capable of driving the switching devices, but also provides the electrical isolation between the control and the high power circuit. This equivalent voltage signal is reinforced by the Schmitt trigger and open collector logic gate. The Schmitt trigger is also used to provide noise rejection and improve the immunity of the circuit. The open-collector gate provides the buffer to allow enough power to turn on the Optocoupler. The HCPL-3120 Optocoupler provides isolation to separate the digital ground of the logic circuit from the floating ground reference of the high power circuit. The output voltage from the Optocoupler is directly fed to the two transistors to provide the gating voltage of +15V and -15V between the gate and the emitter of the IGBTs in order to provide turn on and turn off respectively. Special care must be taken when considering the gate resistance, R_g ; its value determines the speed of the turn on and off which depends on the characteristic of the IGBT module.

5. FULL H Bridge Inverter and Driver Circuits

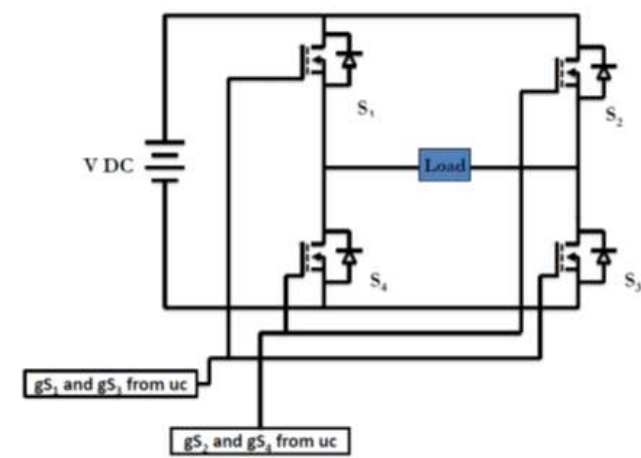

Figure 2: The Full H-bridge single phase inverter

The full H-bridge inverter circuit is used to convert a DC voltage to a sinusoidal AC voltage at a desired output voltage and frequency. Generating a sin wave centered on zero voltage requires both positive and negative voltage across the load. This can be achieved from a single source through the use of H-bridge inverter circuit as shown in Fig. 2. In standard H-bridge circuit, switches S_1 , S_3 , S_2 and S_4 are arranged in this configuration. Both gating signal GS_1 and GS_3 are switched simultaneous at one half of cycle while both gating signal GS_2 and GS_4 are simultaneous switched at the other half. The difference is only at GS_1 and GS_3 signals leading GS_2 and GS_4 by half cycle or 180 degree of the switching signal. The output of the circuit has a periodic waveform that is not sinusoidal. The PIC microcontroller is used to generate the required sinusoidal PWM signals to drive and switch the H-bridge MOSFET transistor. The basic circuit of this system is a PIC microcontroller which is developed to generate a sinusoidal PWM with the dead time controller. The dead time control is useful to reduce the cost and components. The extremely important problem to be considered is the dead time control. The timing diagram of the dead time is shown in Fig. 3. There is a potential overlapping signals between ON period switches pair S_1 , S_4 and S_2 , S_3 pair in H-bridge inverter.

This overlap can cause the short circuit of DC bus. The dead time can be controlled through programming by using PIC microcontroller. The period of dead time must be suitable to avoid the problem of switch damage and harmonic.

III. POWER SYSTEM STABILITY IMPROVEMENT USING THE STATCOM WITH ENERGY STORAGE

The instability of the ac power system with distributed generation (DG) has been analyzed. The dynamic behavior of the rotating machine has been investigated focusing on the variation of the machine speed due to the imbalance between the electrical power output and the mechanical power input. The instability of the mentioned system is concerned with the rate of change of frequency (ROCOF) which is directly proportional to the speed of the rotating synchronous generator applied to the system. If the rate of change of frequency is beyond the acceptable range, the protecting system (which is originally designed to prevent the islanding or loss of main mode operation) will separate and stop the operation of the machine from the system. However the unnecessary tripping (mal-operation) of the protection system will occur following transient events, resulting in a poor security and reliability of the whole system. The idea to minimize the instability has been proposed by applying the instantaneous real power support produced by the STATCOM with energy storage to help the generator to handle the suddenly imbalanced conditions. The minimum amount of the stored energy (rating of the energy storage device) required to stabilize the system frequency has been derived.

IV. SIMULATION RESULTS

Modeled system

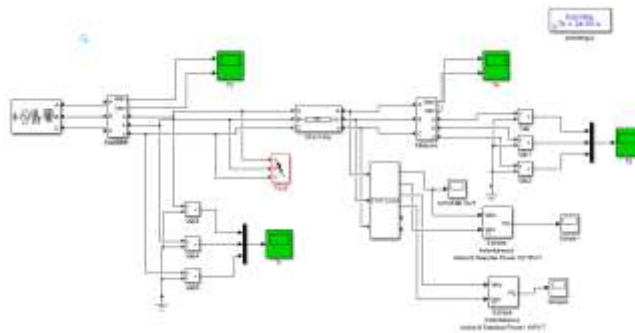

Figure 3: STATCOM without energy storage system

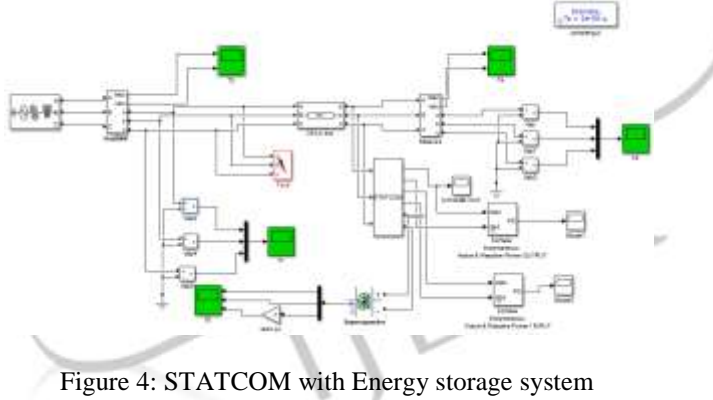

Figure 4: STATCOM with Energy storage system

When the main load is switched on at time $t=0$ s, a sudden change can be seen on the load current in Figure 5. Also, the supply current waveform in the middle trace indicates that all the load demand is still supplied by the three-phase power supply, although the STATCOM is enabled. This current causes a voltage drop across the 5mH inductor. The STATCOM detects the voltage drop at V_{pcc} and then generates the reactive power, proportional to the difference in the voltage from the reference value, in order to keep the voltage at V_{pcc} constant. As a result the controlled current (reactive power current) can be seen as the support current waveform in Figure. The bottom trace shows the reactive power current produced by the STATCOM in responding to the drop in V_{pcc} .

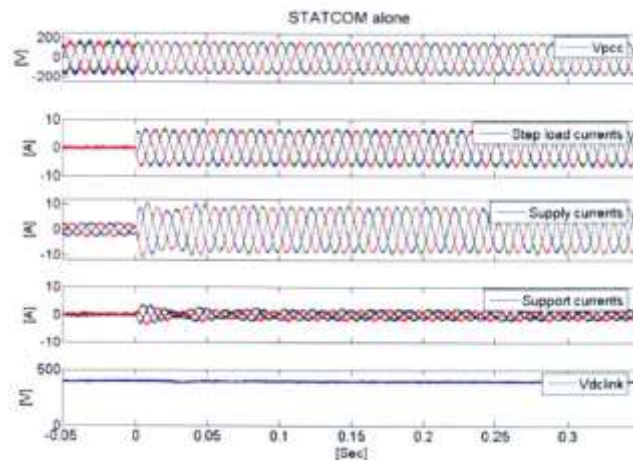

Figure5.Simulation of STATCOM without Supercapacitor

At the time when the main load is switched on, the STATCOM quickly reacts to the sudden voltage drop by supplying the reactive power current (negative I_q) to the ac grid. According to this reactive power current, the magnitude of V_{pcc} increases rapidly. Consequently, as V_{pcc} is controlled by the STATCOM, the amount of the reactive power injection is therefore reduced proportional to the increase of the magnitude of V_{pcc} . During this period, due to the STATCOM supplying current to the ac grid, a small drop in the DC-link voltage is seen, as some energy in the DC-link capacitor is needed to supply losses in the system. According to the STATCOM's DC-link voltage control reacting to this drop in order to maintain the DC-link constant, a small amount of the active power current (I_d) is seen.

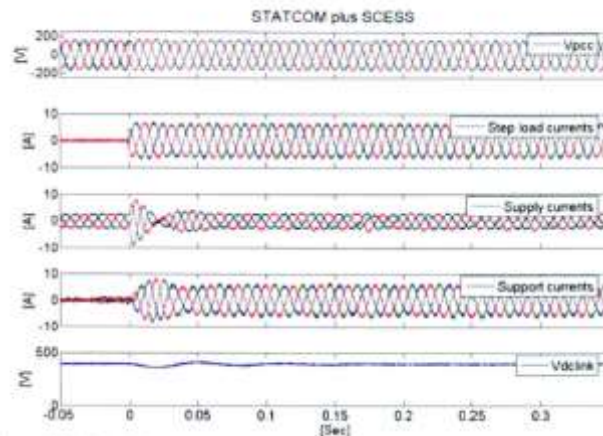

Figure6.Simulation of STATCOM with Supercapacitor

At time $t=0s$, the main load is switched on to the V_{pcc} bus, resulting in a sudden change of the load current. The load change causes a large voltage drop at V_{pcc} . At this moment, the sudden load change and the voltage drop cause the STATCOM unit to operate in full function in order to support both real and reactive power. As a result, from time $t=0s$ onward, the STATCOM unit quickly reacts to the load change, and supplies the load demand seen as the support current trace. Initially, in order to supply the load demand, the STATCOM takes energy from the DC-link capacitor and delivers it to the ac side. During this period, the SCESS is not operating, resulting in a drop in the DC-link voltage until the SCESS starts operating at time. This DC-link voltage is controlled by the SCESS. When it reacts in this boost mode operation, the SCESS takes the stored energy in the supercapacitor modules to the DC-link capacitor, resulting in the rise in the DC-link capacitor. With the control, this rise in the DC-link voltage settles at rated value. As a consequence, an oscillation in DC-link voltage. For the whole process i.e. the boost mode, the stored energy in the supercapacitor is utilized and transferred to the ac power system, with a rate that is proportional to the demand from the ac side. The supercapacitor terminal voltage reduces according to the amount of the energy transferred. At the same time, the STATCOM control reacts quickly to the voltage drop at V_{pcc} and supplies reactive power to the V_{pcc} bus in order to maintain the magnitude of V_{pcc} constant. The demand of this reactive power is extracted from the error in V_{pcc} . Both the active and reactive power currents are controlled.

IV. CONCLUSION

Through a critical survey of the literature for the energy storage system especially for the Supercapacitors energy storage system for improvement of power quality of the different systems; an overview has been presented. Various aspects of the problem, such as to provide ride through, stabilization of power system, to make undispachable power into dispatchable, to

improve power quality of weak transportation system, of aircraft distribution system UPS, elevator and PDS adopting PI control technique, dynamic voltage restorer in the island mode, switching transients mode, grid connected mode, in stand alone for the short term outage. Therefore it would prove a good energy storage option and power quality maintenance purpose with power conditioning system as the cost falls down being the life and its efficiency is very high. The STATCOM enhanced with energy storage is one of the options that can provide the ability to support both the reactive and real power dynamically to the ac grid. This superior ability can give a significant improvement in the performance of the ac power systems. This paper has investigated the use of STATCOM with energy storage.

REFERENCES

- [1] J. Lamoree, D. Mueller, P. Vinett, and W. Jones: "Voltage sag analysis case studies". IEEE Transactions on Industry Applications, vol. 30, No 4, July – Aug. 1994. pp.
- [2] Atputharajah A, Ekanayake J, Jenkins N "Application study of a STATCOM with energy storage", IEE Proceedings Generation Transmission and Distribution, Vol. 150, No 3 May 2003 pp 368-373
- [3] A. Jain, K. Joshi, A. Behal, and N. Mohan, "Voltage regulation with STATCOMs: modeling, control and results," IEEE Transactions on Power Delivery, vol. 21, no. 2, pp. 726-735, Apr 2006.
- [4] H. Chong, A. Q. Huang, M. E. Baren, S. Bhattacharya, W. Litzemberger, L. Anderson, A. L. Johnson, and A. A. Edris, "STATCOM Impact Study on the Integration of a Large Wind Fann into a Weak Loop Power System," IEEE Transactions on Energy Conversion, vol. 23, no. 1, pp. 226-233, Mar 2008.
- [5] Zhengping, X.; Babak, P.; Subhashish, B. Improving distribution system performance with integrated STATCOM and Supercapacitor Energy Storage System. In Proceedings of the IEEE Power Electronics Specialists Conference, Rhodes, Greece, 15–19 June 2008; pp. 1390–1395.

