

# Solar System Monitoring System

<sup>1</sup>Rajyashree, <sup>2</sup>Valiveti Sourabh, <sup>3</sup>K. Naveen, <sup>4</sup>F. Melvin Thomas Raj  
<sup>1</sup>Guide, <sup>2-4</sup>Student, Student, Student  
 Computer Science and Engineering  
 SRM Institute of Science And Technology, Chennai, India.

**Abstract** - Using the Internet of Things Technology for supervising solar power generation can greatly enhance the performance, monitoring, and maintenance of the plant. With the advancement of technologies, the cost of renewable energy equipment is going down globally encouraging large-scale solar plant installations. This massive scale of solar system deployment requires sophisticated systems for automation of the plant monitoring remotely using web-based interfaces as the majority of them are installed in inaccessible locations and thus unable to be monitored from a dedicated location. The Project is based on the implementation of new cost-effective methodology based on IoT to remotely monitoring a solar plant for performance evaluation. This will facilitate preventive maintenance, fault detection of the plant in addition to real-time monitoring.

**Index Terms** - Power Measurement, Wireless Transmission, Internet Of Things, Thingspeak, ATmega 328.

## I. INTRODUCTION

Solar power plants need to be monitored for optimum power output. This helps retrieve efficient power output from power plants while monitoring for faulty solar panels, connections, and dust accumulated on panels lowering output and other such issues affecting solar performance. So here we propose an automated IOT based solar power monitoring system that allows for automated solar power monitoring from anywhere over the internet. We use ATmega controller based system to monitor solar panel parameters. Our system constantly monitors the solar panel and transmits the power output to the IOT system over the internet. Here we use IOT Thingspeak to transmit solar power parameters over the internet to NOT Thingspeak server. It now displays these parameters to the user using an effective GUI and also alerts the user when the output falls below specific limits. This makes remotely monitoring of solar plants very easy and ensures best power output.

## II. LITERATURE SURVEY

Development of an online monitoring and control system for distributed Renewable Energy Sources (RES) based on Android platform. This method utilizes the Bluetooth interface of Android Tablet of Mobile phone, as a communication link for data exchange with digital hardware of power Conditioning Unit.

Introduction to an instant monitoring infrastructure of renewable energy generation system that is constituted with a wind turbine on current and voltage measurements of each renewable source. The related values are measured with the developed sensing circuits and processed by 18F4450 microcontroller of Microchip. The processed parameters are then transmitted to personal computer (PC) over universal series bus (USB) to be saved in database and to observe the system instantly. The Coded visual interface of monitoring software can manage the saved data to analyse daily, weekly and monthly values of each measurement separately.

## III. PROPOSED SYSTEM

### 3.1 ATMEGA 328

The main purpose of using ATmega 328 is its high functionality with simplicity and familiarity. ATmega 328 bridges the gap between solar panel and IoT( Internet of Things). ATmega 328 is powered with 5 volts dc supply for its operation.

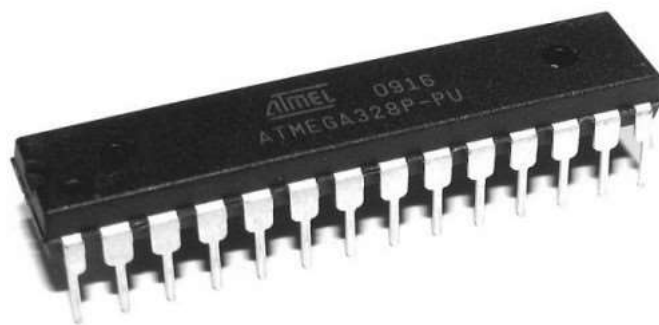

### 3.2 VOLTAGE AND CURRENT SENSOR (INA 219)

As INA219 is current and power sensor which gives the total power consumed by shunt load and gives respective reading in digital form to ATmega 328. ATmega 328, with program loaded in it, calculates the current and voltage reading of shunt load.



### 3.3 LIQUID CRYSTAL DISPLAY (LCD)

LCD is used for displaying the product name& total cost. When product is put into cart after scanning, it will show the cost and name and if second product is scanned, then second product cost will get added and it will be displayed on LCD



### 3.4 Wi-Fi MODULE (ESP8266)

All the calculated data by ATmega 328 is further processed by Wi-Fi Module in order to store on IoT (Internet of Things) Server or Cloud. In order to analyse this data on daily, weekly and monthly basis we are using popular IoT platform Thingspeak

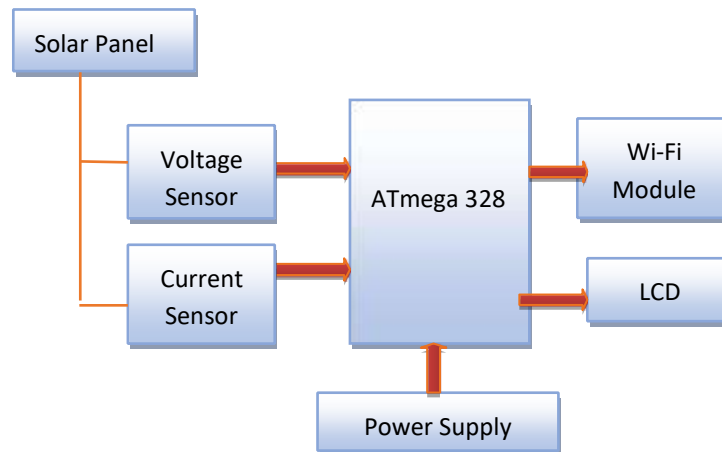

**Figure1-** Block Diagram of Solar System monitoring system using IoT

#### IV. HOW DOES IT WORK?

Internet of Things (IoT) platform integrates data from the different solar panels and applies analytics to share the most valuable information with applications built to address specific needs.

These powerful IoT platforms such as Thingspeak, Microsoft Azure and Google cloud platform etc can pinpoint exactly what information is useful and what can safely be ignored. This information can be used to detect faults, make recommendations, and detect possible problems before they occur.

The information picked up by connected sensors enables to make smart decisions based on real-time information, which helps save time and money.

#### V. CONCLUSION

As this system keeps continues track of solar power plant ,the daily weekly and monthly analysis becomes easy and efficient also with the help of this analysis it is possible to detect any fault occurred within power plant as the generated power may show some inconsistency in data of Solar system.

#### VI. FUTURE SCOPE

Since the system requires external power supply of 5 volts and 3.3 volts for its operation which can be taken rid of by utilising the power generated by solar panel only. Also with the help of motor and controlling it is possible to track the sun for better power generation. Apart from that by using various Machine Learning algorithms and model it is possible to make system smart enough to take decision about data and performance.

#### VII. REFERENCES

- [1] Jiju K. et. al., 2014. "Development of Android based online monitoring and control system for Renewable Energy Sources." Computer, Communications, and Control Technology (I4CT), International Conference on. IEEE, 2014
- [2] Kabalci, Ersan, Gorgun A. and Kabalci Y., 2013. "Design and implementation of a renewable energy monitoring system." Power Engineering, Energy and Electrical Drives (POWERENG), Fourth International Conference on. IEEE, 2013.
- [3] 2013.
- [4] Yoshihiro G. et. al., 2007. "Integrated management and remote monitoring system for telecommunications power plants with fully DC-powered center equipment." INTELEC 07-29th International Telecommunications Energy Conference. IEEE, 2007.
- [5] Alexander S. and Galkin I., 2013. "Case study on using non-intrusive load monitoring system with renewable energy sources in intelligent grid applications." International Conference Workshop And Power Electronic