

Operation of the Electric Power Transmission Line with Injected Third Harmonic Voltage

¹Amol Ankushrao Kale, ²Nitin J. Phadkule

¹ Student, ²Assistant Professor

¹ Electrical Power System,

¹ Government College of Engineering, Amravati, India

Abstract— The objective of injection of third harmonic voltage in transmission lines to reduced peak amplitude of phase voltages. In this proposed method, 13.4 % of peak amplitude of phase voltage is reduced by injecting third harmonic voltage in fundamental component of phase voltage and line to line voltage remains intact. The third harmonic voltage could be injected through line or neutral of transformer. Injected third harmonic voltage does not affect or generation or load side. In this method impact of third harmonic voltage only in phase voltage And does not affected on line to line voltage. With this approach, the existing transmission line can be upgraded by increasing voltage level. In proposed method required less ground clearance compared to practical transmission lines by injecting third harmonic. Furthermore, the capital investment of new construction transmission line could be reduced by shorter length of tower. The loadability of existing transmission lines can be increased, if clearance of new phase to phase is met. In this paper, operation of the electric power transmission line with injected third harmonic voltage and practical consideration for its implementation is studied.

Index Terms— third harmonic voltage, power transmission, ground clearance, line upgrading, and line loadability

I. INTRODUCTION

In power systems a load demand are increasing expeditious. To overcome load demand, power utility have to increasing power generations and power transfer to load end. The transmission line required to transfer Power from source to load. Electrical power can be transfer from HVAC and HVDC transmission lines. More efficient over long distances, HVDC transmission can move more power with less electrical losses than an equivalent AC transmission line [1]. Some superior advantage of HVDC over HVAC. The HVDC transmission losses are lower than AC transmission losses in practically all cases. An optimized HVDC power transmission line has lower losses than AC lines of the same capacity. Losses in the converter stations must also be added and they are about 0.6 percent for HVDC Classic and below 1 percent for HVDC Light of the transmitted power in each station. Hence, in a side-by-side comparison, total HVDC transmission losses are still lower than the AC losses in practically all cases. HVDC cables also have lower losses than AC cables. One of the key advantages of HVDC is that it uses the insulating strength of the line continuously rather than only during the crest voltage. Thus for the same level of insulation, the DC voltage can be at least $\sqrt{2}$ times the rms-value of AC voltage [2].

Some advantages of HVDC are higher efficiency, lower electrical losses, less stress, provides instant and precise control of the power flow and also HVDC has some limitation for short and medium transmission lines. In the past decades, transmission line are proposed Half-wavelength [2], four-phase [3] and combined AC-DC [4]. Yet they have not become practical. In fact, conventional HVAC lines are still a common solution to transfer power at short or medium distances. In power load has tremendous growth in day by day and capacity of generation also increasing. Power utility have to transfer the bulk amount power from source to load sites required high power transmission capability. For that some method are used to increased transmission line capability. These methods are:

1. Superposition of higher voltages on existing systems
2. Building of new lines or circuits at existing voltages.
3. Increased loading of existing lines.

The building of new lines has more expensive as compared to superposition of higher voltages on existing systems. But increasing voltage or loading of existing transmission line it is required large ground clearance for that increasing tower heights, adding midspan towers [5]. All these approaches require tower or conductor modifications which are costly and time consuming. In this report, the proposed of power transmission line design method is reduces the required conductor-to-ground clearance by injecting Third Harmonic Voltage (THV). As a result, this system can be implemented using less-expensive and shorter transmission towers. The existing conventional HVAC lines could also be upgraded with this method to increase their ground clearance, if desired. Injection of THV can also increase the loadability of existing AC lines, if the new phase to-phase clearance is met. As an example, there are many existing AC lines in North America that are limited in capacity due to the ground clearance which can be as high as 25% of the line's capacity [5].

A lot of research work and publications is available on upgrading of existing transmission line and construction of new transmission line. In each case, various techniques were used and has their own advantages and disadvantages. Some techniques need more initial cost or time consuming. Up to the mark required such techniques has less initial cost and less time consuming.

II. CONCEPT OF THIRD HARMONICS VOLTAGE INJECTION

1. Third Harmonic Generator (THG):

The third harmonic generator nothing but it has frequency three times of the fundamental frequency. The single phase synchronous machine or inverter can be implemented as third harmonic generator. In case of synchronous machine, higher pole number (**P**) or mechanical speed (**n_s**) must be selected. The mathematical relation between electrical frequency and number of pole could be expressed as:

$$n_s = \frac{120f}{p} \quad (1)$$

Here, $f = 150 \text{ Hz}; n_s \times p = 18000$.

Therefore, small scale synchronous machine could be reduced speed by increasing no of pole and another approach is to use single phase inverter by using step up transformer shown in fig. 4. To ensure the correct combination of fundamental and THV components, a phase lock loop (PLL) [6] unit must be connected to THG. Function of PLL is generate output signal whose phase is related to the phase of an input signal.

2. Third harmonic injection in power electronics:

Generally, undesired frequency such that any frequency except fundamental frequency and its try to removed out from the system. However, power electronics engineers have benefited from undesired frequency such as third harmonic voltage to pulse width modulation in an inverter for few decades [7]-[8]. it is achievable to get a peak to peak line output voltage of inverter is 15 % more than DC link voltage by adding third harmonic voltage. While line to line voltage undistorted.

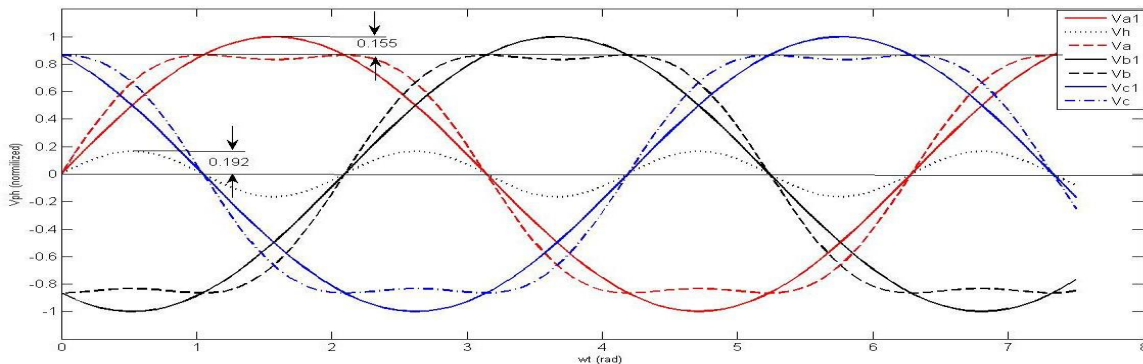

Fig. 1. Increasing inverter gain by THV injection

Shown in fig. 1, the output of three phase inverter are Va, Vb and Vc and Vh is third harmonic voltage. However, third harmonic voltage injected to output of three phase inverter thus their fundamental component Va1, Vb1, Vc1 are increased by 15.5%. To conclude, third harmonic voltage injection is used in an inverter system to increase the modulation index range and without increasing the voltage rating of these devices, the inverter voltage rating is increased.

3. Third Harmonic Injection, a proposal in Power Systems:

The key determinant of transmission line investment is its voltage level and thus may be the cost of any improvement in the sector-benefits. In fig 1, the injection was given to increase the peak amplitude of phase voltage in THV. The same concept could be implemented to reduce the peak amplitude of phase voltages. The implementation of third harmonic voltage injected through sending end transformer shown in fig.2.

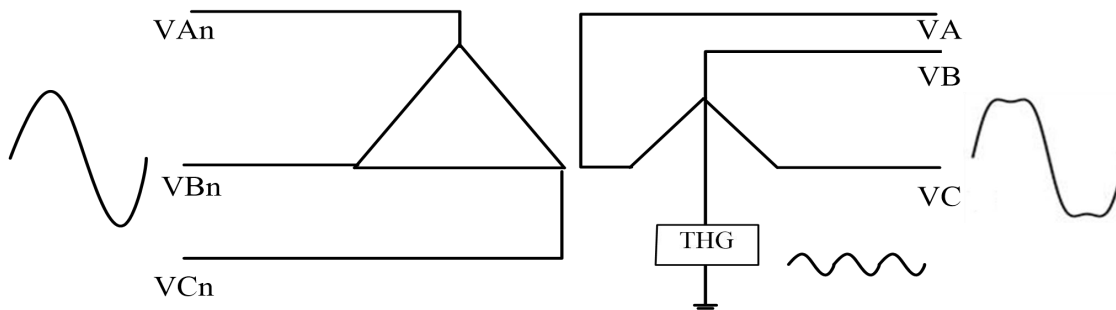

Fig. 2 Sending-end transformer with THV injection.

In Fig.2, the third harmonic voltage Vh injected through neutral of sending end transformer secondary winding and got a phase voltage VA, VB and VC which has peak amplitude decreases by 13.3 %. The mathematical expression of fundamental and third harmonic voltages as follows:

$$\begin{aligned}
 V_A &= V_{An} + V_h = V\sin(\omega t) + V_h \sin(3\omega t), \\
 V_B &= V_{Bn} + V_h = V\sin(\omega t - 2\pi/3) + V_h \sin(3\omega t), \\
 V_C &= V_{cn} + V_h = V\sin(\omega t + 2\pi/3) + V_h \sin(3\omega t),
 \end{aligned}
 \tag{2}$$

Where, V_A , V_B and V_C are the total components of phase voltages. And V_{Kn} ($K = A, B, C$) are fundamental components of phase voltages, ω is the system angular frequency. The third harmonic voltage is denoted by V_h which has one sixth of peak amplitude of fundamental phase voltages V . It should be remembered that line to line voltage remains intact. Fig.3. shows that injecting THV could decrease the peak amplitude of phase voltages by 13.4%.

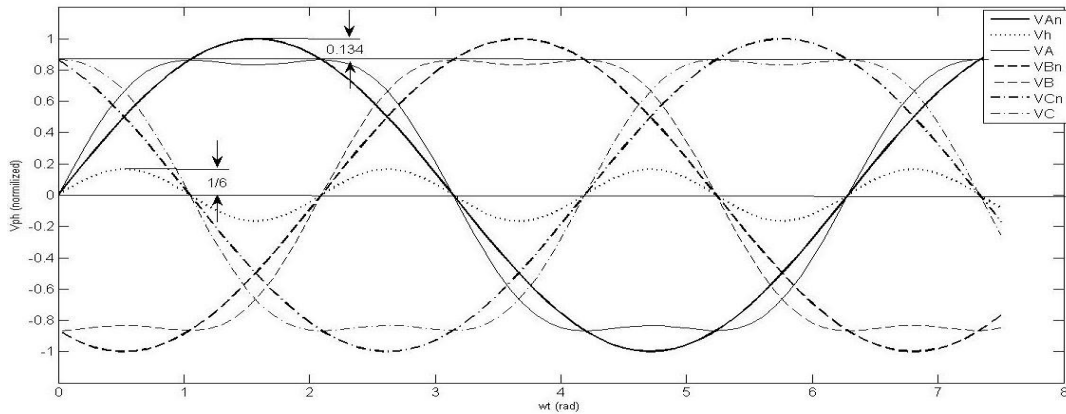

Fig. 3. Decreasing voltage peak amplitude by THV injection

II. EXPLANATION OF THE PROPOSED LINE DESIGN METHOD

1. FOR SHORT AND MEDIUM TRANSMISSION LINES

Fig.4 shows the simplified diagram of proposed transmission lines with injected third harmonic voltage.

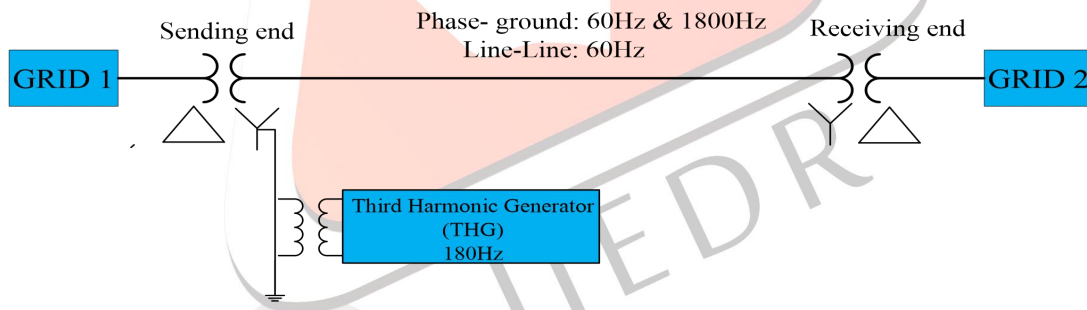

Fig.4 shows the simplified diagram of proposed transmission lines with injected third harmonic voltage

The third harmonic voltage is injected to transmission lines through sending end neutral by single phase third harmonic generator. Third harmonic generator (THG) nothing but generator frequency could be three times the fundamental frequency. The THG can be fulfilled by single phase inverter or synchronous machine. The receiving side transformer neutral is not grounded, thus third harmonic current does not get return path and would not present to power flow. Adding third harmonic voltages are cophasal, thus THV vanishes in line to line voltage.

2. FOR LONGER TRANSMISSION LINE

In this section, the proposed two alternative methods for overcoming arrival time difference [9] and variation of peak amplitude of phase voltage in transmission lines [9]. Two alternative methods for longer transmission lines.

2.1 Third Harmonic voltage Injection through Neutral of Transformer

In this alternative method for longer transmission lines, a delta-star with neutral transformer configuration is used at the sending end and a star-delta with neutral transformer configuration is used at the receiving end of the system. The single phase third harmonic voltage could be generated either by a single phase synchronous generator whose frequency is three times the fundamental frequency or by a single phase inverter using pulse width modulation. After injection of third harmonic voltage, only the phase-to-ground voltage is affected, while the line-to-line voltage remains intact. Single line diagrams of the proposed alternatives for longer transmission lines are shown below.

lines by neutral-fed shown in figure 5. The two third harmonic voltages could be injected sending and receiving end side. Shown in fig. 5.

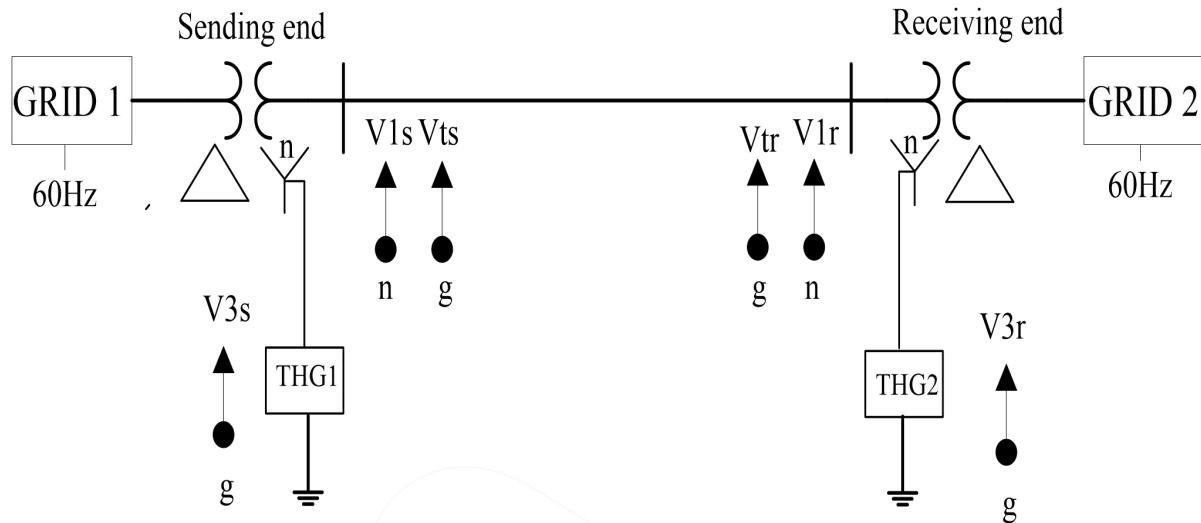

Fig. 5 Single line diagram of the proposed alternatives for longer transmission lines by neutral-fed

Third harmonic voltages injected by third harmonic generator through neutral of star winding of both sides of transformer and fig. 5.

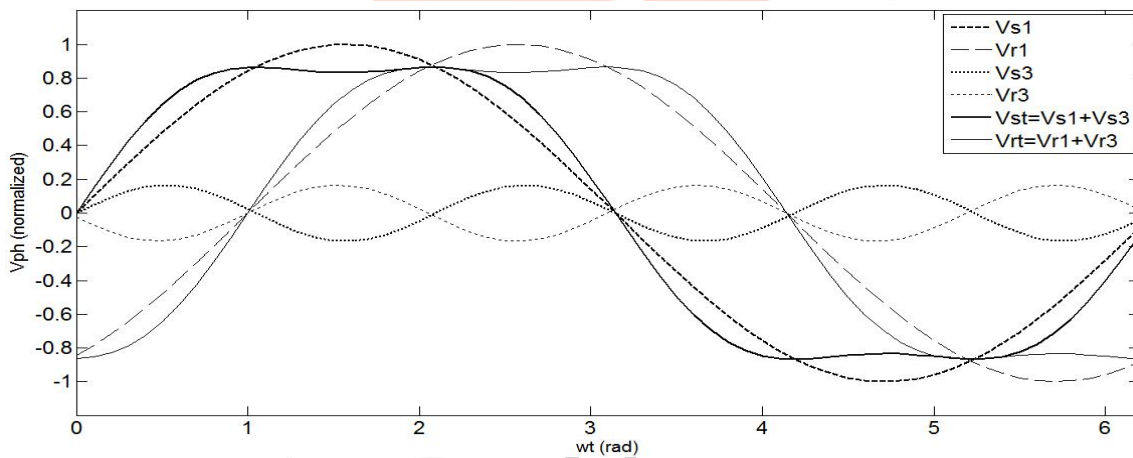

Fig. 6 Voltage distribution of the line with two THGs by neutral fed

Shown in figure 6, Vs1 and Vs3 are the fundamental and third harmonic voltages, Vr1 and Vr3 are the fundamental and third harmonic voltage distribution. After inject third harmonic voltage, get Vst and Vrt are total resultant phase to ground voltages.

2.2 Third Harmonic Voltage Injection by Line Fed

In this alternative method, the third harmonic voltage injection in each phase by using current transformer. In this longer transmission lines required delta-star with ground transformer configuration at sending end and star-delta with ground transformer configuration at receiving end of system shown in figure 7. In this method required two third harmonic voltages generator. The third harmonic generator generate three phase voltage whose frequency three times the fundamental frequency and magnitude one sixths of fundamental phase to ground peak voltages. Third harmonic phase voltage could be generate by three phase inverter by using PLL it could be inject proper third harmonic voltage in this system. Shown in figure 7, third harmonic voltage inject by using AC to AC converter on both sending and receiving end of transmission line.

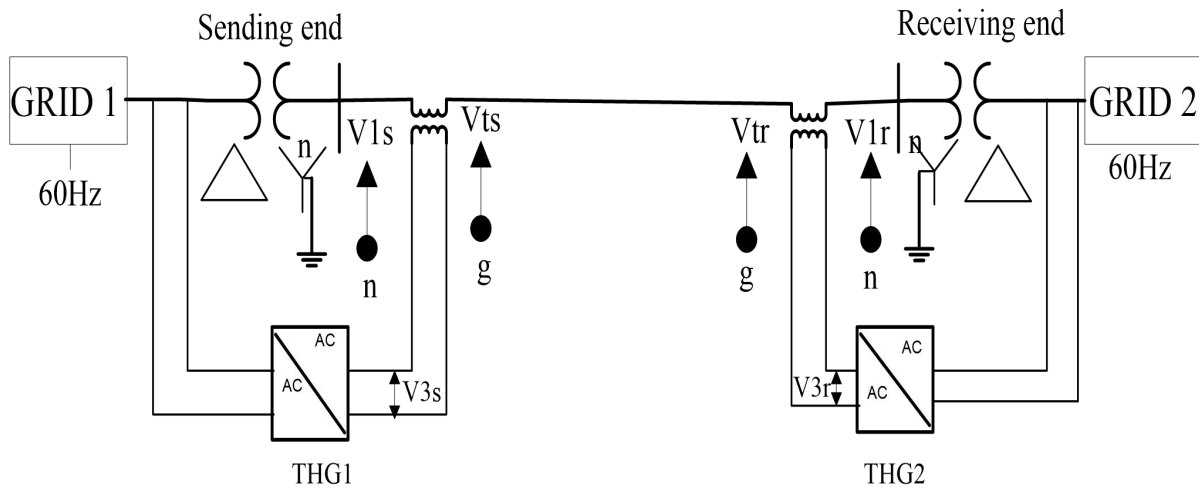

Fig. 7 Single line diagram of the proposed alternatives for longer transmission line by line-fed

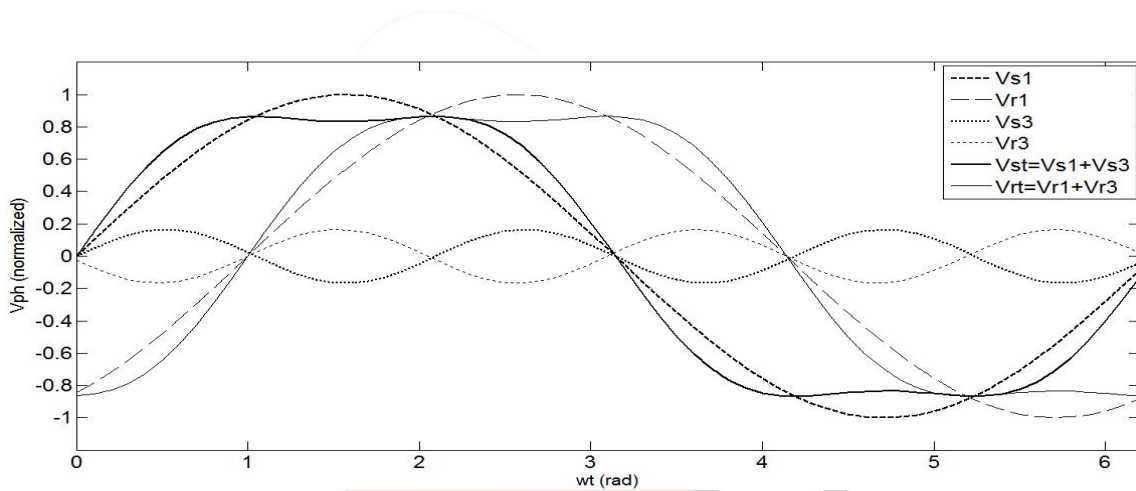

Fig. 8 Voltage distribution of the line with two THGs by line fed

Shown in figure 8, V_{s1} and V_{s3} are the fundamental and third harmonic voltages, V_{r1} and V_{r3} are the fundamental and third harmonic voltages. After inject third harmonic voltage, get V_{st} and V_{rt} are total resultant phase to ground voltage distribution. As compare both method same effect occurrences on resultant voltage after injecting third harmonic voltages.

III. INFLUENCE OF THIRD HARMONIC INJECTION

1. Influence of Third Harmonic Injection on Ground Clearance:

One of the important components of any overhead transmission line are transmission towers. Their work is to keep high-voltage conductors separated from each other and provide some kind of approval. To know the effect of third harmonic injection on the needed clearances, they are first presented as follows:

1.1. Phase-to-Phase Clearance:

It is adequate clearance between two phase conductors of electrical transmission line. It is adequate clearance between two Phase conductors of electrical transmission line. It is required to prohibit swinging contacts and flashovers between conductors. For calculating phase to phase clearance line to line voltage is main deciding factor [9].

1.2. Clearance between phase conductor and earth wire:

It is also known as clearance between Air Clearance. To ensure the clearance of air, the conductor is able to withstand the overvoltage due to electric power frequency and switching or lightning sources [10].

1.3 Ground Clearance:

The clearance between ground and mid-span of lowest conductor of transmission lines is known as ground clearance. It is required to maintain safety clearance of phase conductor to ground for prevent accident. It is dependence on the type of surrounding area and operating maximum phase to ground voltage. For example, RUS Bulletin 1724E-200, “Design manual for high voltage transmission lines,” Electric Staff Division, Rural Utilities Service, U.S. Department of Agriculture, Washington, USA, Tech. Rep., 2009. For example As per Indian Electricity Rule 1956, Clause No 77, the minimum distance between bottom conductor and ground of a 33KV uninsulated electrical conductor is 5.2 meter, is increased by 0.3 meter for every 33KV above 33KV. for example of 230kv transmission line would be

$$230KV - 33KV = 197KV \text{ and } 197KV/33KV \approx 5.9696$$

$$\text{Now, } 5.9696 \times 0.3 = 1.79 \text{ meter.}$$

So, as per logic, the ground clearance of 220KV bottom conductor would be, $5.2 + 1.79 = 6.99 \approx 7$ meter.

The proposed method reduces the peak amplitude of phase voltages and leaves the line-to-line voltages intact. Thus, the ground clearance requirement could be reduced while air and phase-to-phase clearances continue to be fulfilled. Transmission Companies could be cut the line investment by using shorter electrical transmission towers and narrower ROW.

2. Influence of Third Harmonic Injection on Line Loadability:

The without exceeding the ground clearance, the rms-value of the phase voltages can be increased by 15.5% as shown in figure 1. This increases the surge impedance loading (SIL) of the line by 33%, which relates directly to line loadability [9]. The design transmission lines could be increased up to 15.5 % without affecting ground clearances. Since the peak-amplitude of phase voltages remain same. The loadability of transmission line can be increase by increasing phase voltage but phase to phase clearance also increases. In fact, many transmission tower types are capable of providing high phase to phase approvals and they are mostly limited by their air clearances. Air clearance remains intact due to injecting third harmonic voltage. Thus, it can be concluded that the transmission tower is likely to be eligible for THV upgrade by injections compared to conventional voltage uprating. H.P. St. Clair introduced the concept of line loadability expressed as a percentage of surge impedance load (SIL) in 1953 through St. Clair curves [12]. The universal loadability curve was used in approximately calculating the loadability of transmission lines of the network. There are three factors that limit the power through a transmission line, the thermal limit, limit of voltage drop and small-signal stability limit .The value of SIL was calculated,

$$SIL = \frac{V_{LL}}{Z_{Surge}} = 3 \frac{V_{ph}^2}{Z_{surge}} \quad (3)$$

V_L Is the rated line to line voltage of the transmission line and Z_c is the characteristic impedance of the line.

II. SIMULATION MODEL

The general model of 230kV H-frame transmission line without injecting third harmonics voltages see Fig. 9. The length of the line is 300km and it is designed to transmit 150MVA using single bundle conductor of Martin.

Table 1: parameter of transmission line

Sr.No.	Parameter	Per km
1	R1	0.04524 Ω
2	R0	0.36124 Ω
3	L1	1.2538 mH
4	L0	3.8328 mH
5	C1	9.3053 nF
6	C0	5.8331 nF

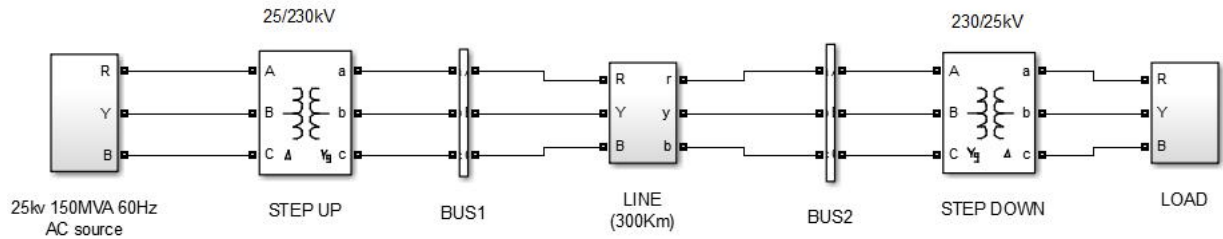

Fig.9 Simulation model without third harmonic voltage injection

The power system model are run in MATLAB/SIMULINK shown in fig.9 and Three phase sending end and receiving end phase to ground fundamental voltages shown in fig.12(a).In this resultant voltage waveform there is no peak reduced and peak amplitude of sending end and receiving end voltage are 184.68kV and 167.16kV.

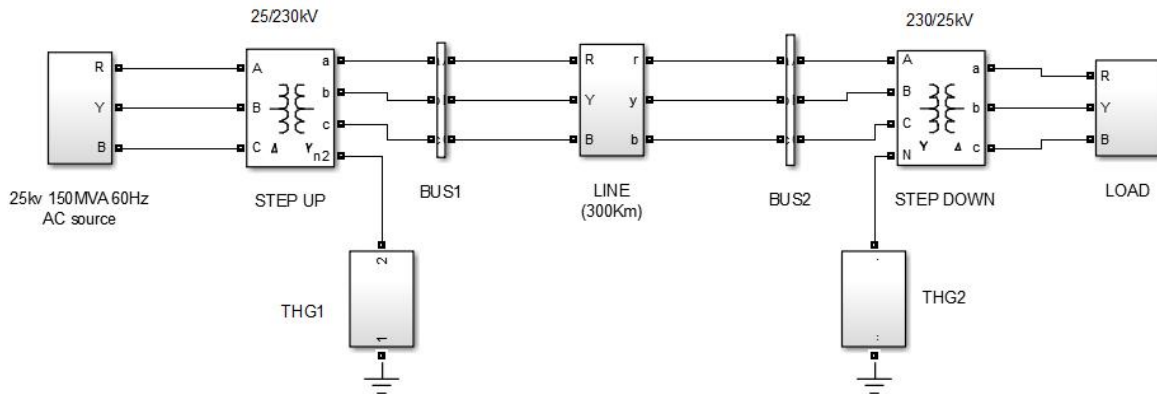

Fig10 Simulation model with third harmonic voltage injection

The simulation model of proposed method where THV is injected at both ends of the line as shown in Fig.10. The third harmonic voltages are injected locally by two third harmonic generator through single phase transformer. After run the simulation model, the resultant waveform of sending end three phase shown in fig 12(b) and receiving end three phase voltage shown in fig.12(c). Therefore, the least peak amplitude of the phase voltages are ensured along the line. V_s (a, b, c) and V_r (a, b, c) are the sending and receiving end phase voltages shown in fig.12. After the injection of third harmonics voltages on both ends, peak amplitude of sending end voltages drops from 184.68kV to 159.4kV as shown in fig.12(b)and peak amplitude of phase voltages drops from 167.16kv to 145.4kV as shown in fig.12(c)

The power system simulation model for compare fundamental and resultant phase voltages shown in fig. 11. Comparison between total phase voltage and fundamental phase voltage presents in fig.12 (d).

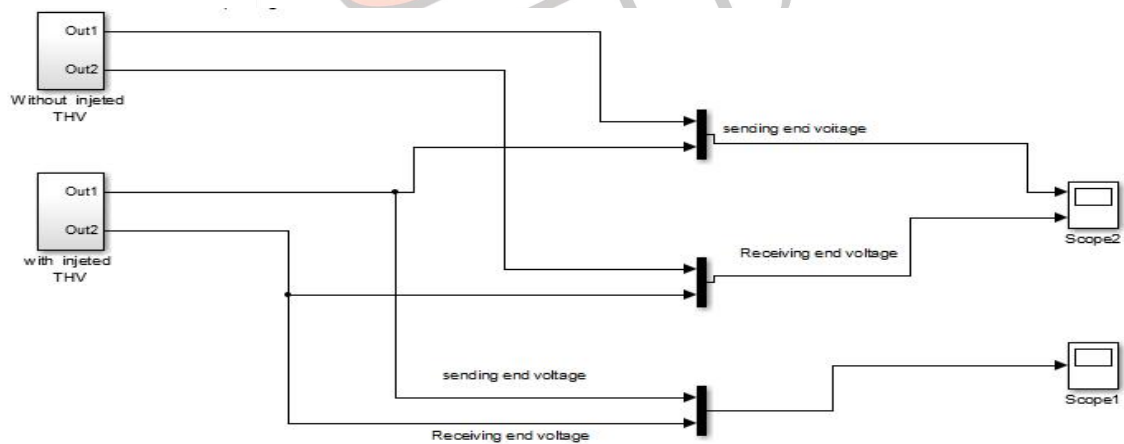
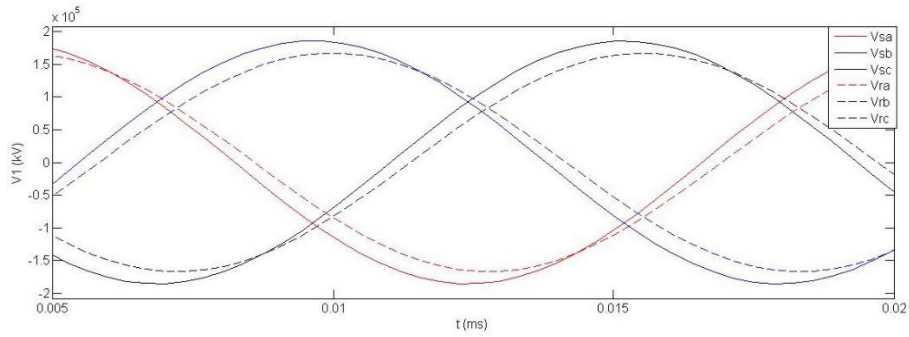
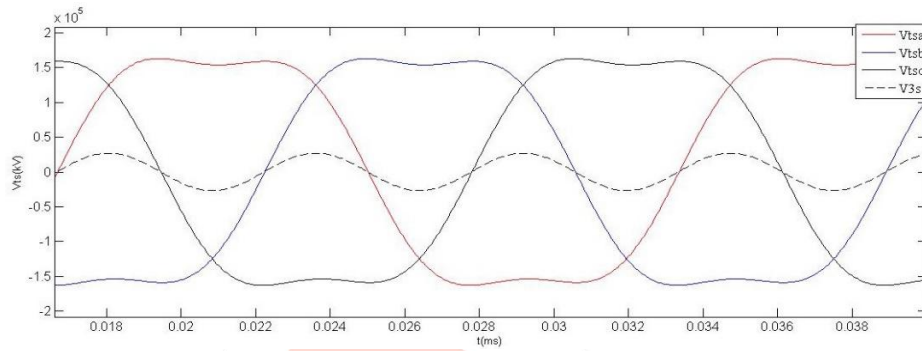

Fig.114.4 Comparison of two models



(a) Fundamental component of the phase voltages



(b) Sending end phase voltage by injecting third harmonic voltage

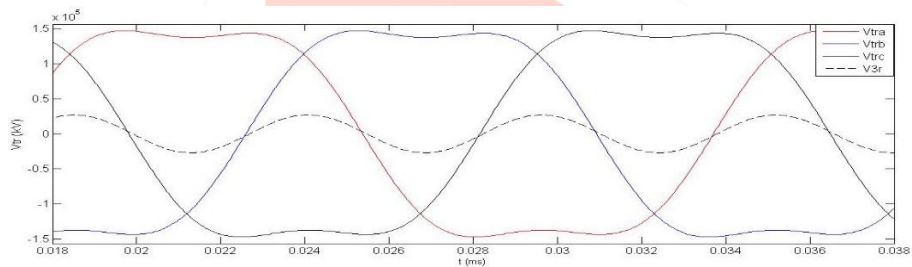

(c) Receiving end phase voltage by injecting third harmonic voltage

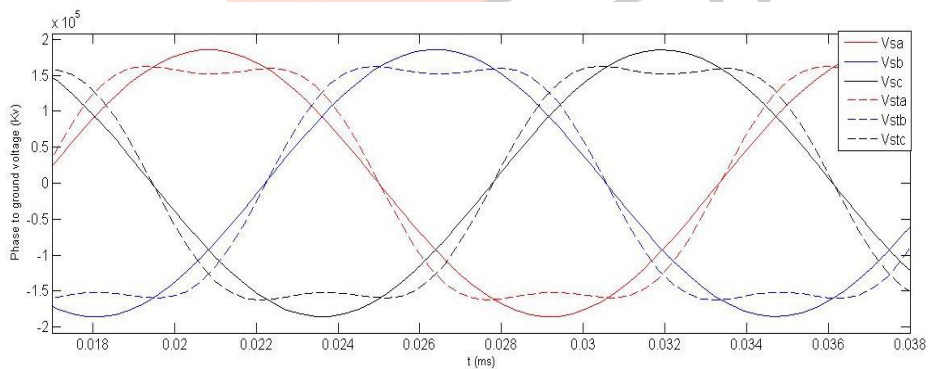

(d) Compare fundamental and total phase voltage at sending end

Fig.124.5 simulation result

Table 2: Peak Phase Voltages Of Transmission Line

Peak phase voltage	Without injected THV	With injected THV
Sending end	184.68 kV	159.4 kV
Receiving end	167.16 kV	145.4 kV

The peak amplitude of phase voltage with and without injection shown in table 2. Finally concludes that the theoretically and practically verify the peak amplitude of phase voltages are reduced by 13.3% after injecting third harmonic voltage. According to [9], phase to ground clearance reduced while line to line voltage remains intact. Therefore, existing transmission line could

be upgraded or new transmission line can be constructed by shorter transmission tower. Table 3 summarizes components of active and reactive powers at both sending and receiving ends.

Table 3: Active And Reactive Power Components

Parameter	Sending end	Receiving end
Active power (MW)	48.17	47.28
Reactive (MVAR)	8.15	4.82

V. RESULTS AND DISCUSSION

The proposed method is discussed that injection of third harmonic voltage in transmission line to reduce peak amplitude of phase voltage and ground clearance dependence on peak amplitude of phase voltage. Thus, reduces the required conductor-to-ground clearance by injecting third harmonic voltage. The loadability of transmission line can be increased by injecting third harmonic voltage. Thus, transmission line could be upgraded. To reduces the required conductor-to-ground clearance by injecting third harmonic voltage.

REFERENCES

- [1] T. Halder, "Comparative study of HVDC and HVAC for a bulk power transmission," in *Proc. International Conference on Power, Energy and control (ICPEC)*, Sri Ranganlatchum Dindigul, India, 13 June 2013.
- [2] F. Hubert and M. Gent, "Half-wavelength power transmission lines," *IEEE Transactions on Power Apparatus and Systems*, vol. 84, no. 10, pp. 965–974, 1965.
- [3] G.Y. Liu and Y.H. Yang, "Four-phase transmission systems and estimation of effectiveness of their application for power transmission from the three Gorges plant to East China," in *proc. International Conference on Power System Technology*.
- [4] H. Rahman and B. H. Khan, "Power upgrading of transmission line by combining AC- DC transmission," *IEEE Transactions on Power Systems*, vol. 22, no. 1, pp. 459–466, 2007.
- [5] B Reisdorff, "Increasing transmission capacity case studies and techniques, increased transmission capacity by increasing ground clearance - a manufacturers perspective," in *Proc. IEEE International Conference on Transmission & Distribution Construction, Operation and Live-Line Maintenance (ESMO)*, Albuquerque, USA, Oct. 2006, pp. 1–7.
- [6] G.-C. Hsieh and J. C. Hung, "Phase-locked loop techniques. A survey," *IEEE Transactions on Industrial Electronics*, vol. 43, no. 6, pp. 609–615, 1996.
- [7] J. A. Houldsworth and D. A. Grant, "The use of harmonic distortion to increase the output voltage of a three-phase PWM inverter," *IEEE Transactions on Industry Applications*, vol. IA-20, no. 5, pp. 1224–1228, 1984.
- [8] M. A. Boost and P. D. Ziogas, "State-of-the-art carrier PWM techniques: a critical evaluation," *IEEE Transactions on Industry Applications*, vol. 24, no. 2, pp. 271–280, 1988.
- [9] Ramiar Alae and S. Ali Khajehoddin, "The operation of a power transmission line with injected third harmonic voltage," *IEEE Trans. On Power Delivery Volume: 32, Issue: 1, Feb. 2017*.
- [10] RUS Bulletin 1724E-200, "Design manual for high voltage transmission lines," Electric Staff Division, Rural Utilities Service, U.S. Department of Agriculture, Washington, USA, Tech. Rep., 2009.
- [11] S. Venkatesan, R. Bhattarai, M. Osborne, A. Haddad, H. Griffiths, and N. Harid, "A case study on voltage uprating of overhead lines air clearance requirements," in *Proc. International Universities Power Engineering Conference (UPEC)*, Cardiff, Wales, Sep. 2010, pp. 1 – 5
- [12] P. Kundur, N. J. Balu, and M. G. Lauby, *Power system stability and control*. New York: McGraw-Hill, 1994.