

A DC-DC Power Converter by a Fuzzy Logic Controlled Solar Power Generation System with Seven Level Inverter

¹Adapa Sai Kiran, ²Sammangi Ramyaka
¹Student, ²Assistant Professor
 Nri Institute Of Technology

Abstract - This project proposes a new solar power generation system, which is composed of a DC-DC power converter and a new seven level inverter. The DC-DC power converter integrates a DC-DC boost converter and a transformer to convert the output voltage of the solar cell array into two independent voltage sources with multiple relationships. This new seven-level inverter is configured using a capacitor selection circuit converts the two output voltage sources of DC-DC power converter into a three-level DC voltage, and the full-bridge power converter further converter into a three-level DC voltage into a seven-level ac voltage. In this way, the proposed solar power generation system generated a sinusoidal output current that is in phase with the utility voltage and is fed into the utility. The salient features of the proposed seven-level inverter are that only six power electronic switches are used, and only one power electronic switch is switched at high frequency at ant time.

keywords - Grid connected, DC-DC converter, Multi-level inverter, Pulse width modulation (PWM),Fuzzy logic controller.

I. INTRODUCTION

The extensive use of fossil fuels has resulted in the global problem of greenhouse emissions. Moreover, as the supplies of fossil fuels are depleted in the future, they will become increasingly expensive. Thus, solar energy is becoming more important since it produces less pollution and the cost of fossil Fuel energy is rising, while the cost of solar arrays is decreasing. In particular, small-capacity distributed power generation systems using solar energy may be widely used in residential applications in the near future [1].

The dc-dc boost converter can be advantageous for Step-up applications that do not demand very high voltage gain, mainly due to the resulting low conduction loss and design simplicity. Theoretically [2], the boost converter static gain tends to be infinite when duty cycle also tends to unity.

Among different renewable energy sources, the photovoltaic cell and fuel cell have been considering attractive choice. However, without additional arrangements, the output voltages generated from both sources. Thus, a high step-up dc-dc converter is desired in the power conversion systems corresponding to these two energy sources. In addition to the mentioned applications, a high step-up dc-dc converter is also required by many industrial applications, such as high-intensity discharge lamp ballasts for automobile headlamps and battery backup systems for uninterruptible power supplies.

The power conversion interface[5]-[6] is important to grid connected solar power generation systems because it converts the dc power generated by a solar cell array into ac power and feeds this ac power into the utility grid. An inverter is necessary in the power conversion interface to convert the dc power to ac power. Since the output voltage of a solar cell array is low, a dc-dc power converter is used in a small-capacity solar Power generation system to boost the output voltage, so it can match the dc bus voltage of the inverter. The power conversion efficiency of the power conversion interface is important to insure that there is no waste of the energy generated by the solar cell array. The active devices and passive devices in the inverter produce a power loss. The power losses due to active devices include both conduction losses and switching losses. Conduction loss results from the use of active devices, while the switching loss is proportional to the voltage and the current changes for each switching and switching frequency. A filter inductor is used to process the switching harmonics [4] of an inverter, so the power loss is proportional to the amount of switching harmonics. The voltage change in each switching operation for a multilevel inverter is reduced in order to improve its power conversion efficiency and the switching stress of the active devices [4]. The amount of switching harmonics is also attenuated, so the power loss caused by the filter inductor is also reduced. Therefore, multilevel inverter technology has been the subject of much research over the past few years. In theory, multilevel inverters should be designed with higher voltage levels in order to improve the conversion efficiency and to reduce harmonic content and electromagnetic interference (EMI).

PROPOSED SOLAR POWER GENERATION CIRCUIT

Fig. 1 shows the configuration of the proposed solar power generation system [1]. The proposed solar power generation system is composed of a solar cell array, a dc-dc power converter, and a new seven-level inverter. The solar cell array is connected to the dc-dc power converter, and the dc-dc power converter is a boost converter that incorporates a transformer with a turn ratio of 2:1. The dc-dc power converter [2] converts the output power of the solar cell array into two independent voltage sources with multiple relationships, which are supplied to the seven-level inverter. This new seven-level inverter is composed

of a capacitor selection circuit and a full-bridge power converter, connected in a cascade. The power electronic switches of capacitor selection circuit determine the discharge of the two capacitors while the two capacitors are being discharged individually or in series. Because of the multiple relationships between the voltages of the dc capacitors, the capacitor selection circuit outputs a three-level dc voltage. The full-bridge power converter further converts this three-level dc voltage to a seven-level ac voltage that is synchronized with the utility voltage. In this way, the proposed solar power generation system generates a sinusoidal output current that is in phase with the utility voltage and is fed into the utility, which produces a unity power factor. As can be seen, this new seven-level inverter contains only six power electronic switches [3], so the power circuit is simplified.

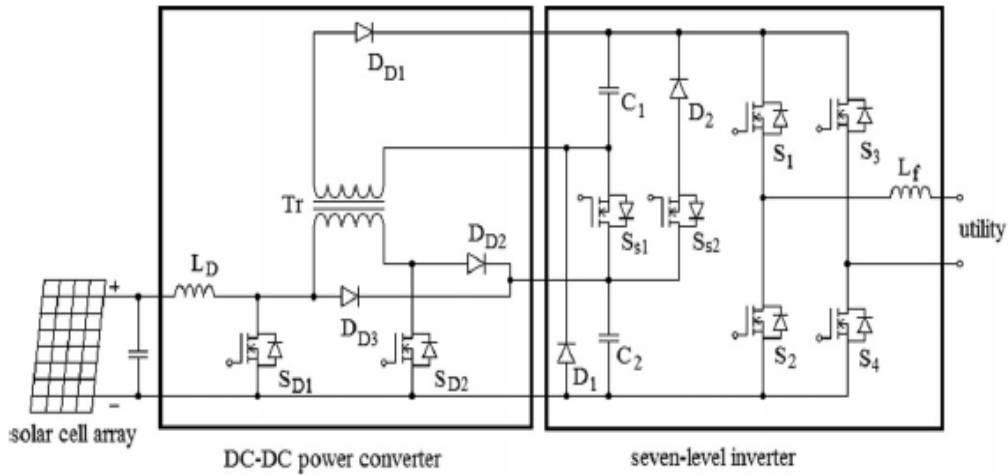

Fig.1 proposed solar power generation.

Because of the multiple relationships between the voltages of the dc capacitors, the capacitor selection circuit outputs a three-level dc voltage. The full-bridge power converter further converts this three-level dc voltage to a seven-level ac voltage that is synchronized with the utility voltage. In this way, the proposed solar power generation system generates a sinusoidal output current that is in phase with the utility voltage and is fed into the utility, which produces a unity power factor. As can be seen, this new seven-level inverter contains only six power electronic switches, so the power circuit is simplified.

DC-DC POWER CONVERTER

As seen in Fig. 2, the DC–DC power converter [1] incorporates a Boost converter and a current-fed forward converter. The boost converter is composed of an inductor L_D , a power electronic switch $SD1$, and a diode, $DD3$. The boost converter charges capacitor $C2$ of the seven-level inverter. The current-fed forward converter is composed of an inductor L_D , power electronic switches $SD1$ and $SD2$, a transformer, and diodes $DD1$ and $DD2$. The current-fed forward converter charges capacitor $C1$ of the seven-level inverter. The inductor L_D and the power electronic switch $SD1$ of the current-fed forward converter are also used in the boost converter [2].

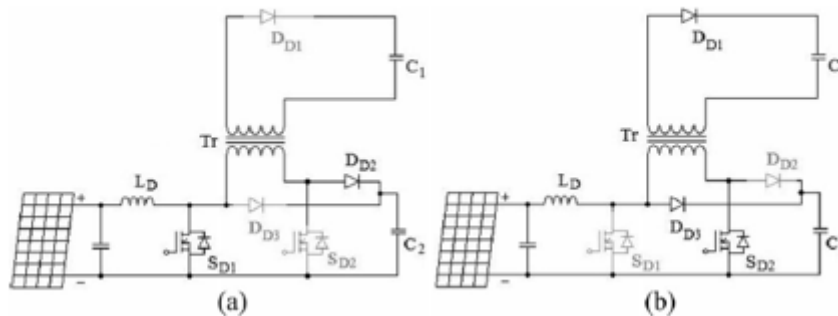

Fig.2 operation of DC-Dc converter (a) SD1 on (b) SD1 off

Fig (2) shows the operation of Dc-Dc power converter. Fig. 2(a) shows the operating circuit of the dc–dc power converter when $SD1$ is turned ON. The solar cell array supplies Energy to the inductor L_D . When $SD1$ is turned OFF and $SD2$ is turned ON, its operating circuit is shown in Fig. 2(b). Accordingly, capacitor $C1$ is connected to capacitor $C2$ in parallel through the transformer, so the energy of inductor L_D and the solar cell array charge capacitor $C2$ through $DD3$ and charge capacitor $C1$ through the transformer and $DD1$ during the off state of $SD1$. Since capacitors $C1$ and $C2$ are charged in parallel by using the transformer, the voltage ratio of capacitors $C1$ and $C2$ is the same as the turn ratio (2:1) of the transformer. Therefore, the voltages of $C1$ and $C2$ have multiple relationships. The boost converter is operated in the continuous conduction mode (CCM).

The voltage of $C2$ can be represented as

$$V_{c2} = \frac{1}{1-D} V_s$$

Where V_s is the output voltage of solar cell array and D is the duty ratio of $SD1$. The voltage of capacitor $C1$ can be represented as

$$V_{c1} = \frac{1}{2(1-D)} V_s$$

It should be noted that the current of the magnetizing inductance of the transformer increases when $SD2$ is in the ON state. Conventionally, the forward converter needs a third demagnetizing winding in order to release the energy stored in the magnetizing inductance back to the power source. However, in the proposed dc-dc power converter, the energy stored in the magnetizing inductance is delivered to capacitor $C2$ through $DD2$ and $SD1$ when $SD2$ is turned OFF. Since the energy stored in the magnetizing inductance is transferred forward to the output capacitor $C2$ and not back to the dc source, the power efficiency is improved. In addition, the power circuit is simplified because the charging circuits for capacitors $C1$ and $C2$ are integrated. Capacitors $C1$ and $C2$ are charged in parallel by using the transformer, so their voltages automatically have multiple relationships. The control circuit is also simplified.

SEVEN LEVEL INVERTER

The seven-level inverter is composed of a capacitor selection circuit and a full-bridge power converter, which are connected in cascade. The operation of the seven level inverter can be divided into the positive half cycle and the negative half cycle of the utility. For ease of analysis, the power electronic switches and diodes are assumed to be ideal, while the voltages of both capacitors $C1$ and $C2$ in the capacitor selection circuit are constant and equal to $V_{dc}/3$ and $2V_{dc}/3$, respectively. Since the output current of the solar power generation system will be controlled to be sinusoidal and in phase with the utility voltage, the output current of the seven-level inverter is also positive in the positive half cycle of the utility. The operation of the seven-level inverter in the positive half cycle of the utility can be further divided into four modes as shown in fig.3.

The seven-level inverter is controlled by the current-mode control, and pulse-width modulation (PWM) is used to generate the control signals for the power electronic switches. The output voltage of the seven-level inverter must be switched in two levels, according to the utility voltage. One level of the output voltage is higher than the utility voltage in order to increase the filter inductor current, and the other level of the output voltage is lower than the utility voltage, in order to decrease the filter inductor current. In this way, the output current of the inverter can be controlled to trace a reference current. Accordingly, the output voltage of the seven-level inverter must be changed in accordance with the utility voltage.

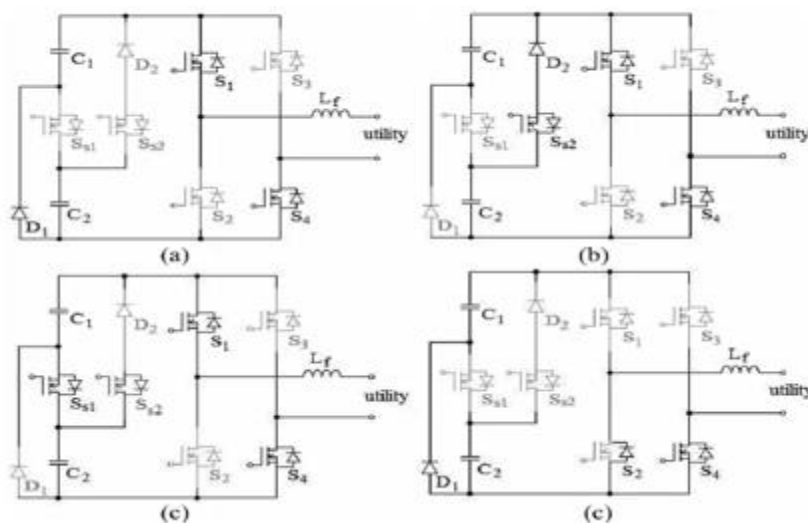

Fig.3 operation of seven level inverter.

Mode 1: The operation of mode 1 is shown in Fig. 3(a). Both $SS1$ and $SS2$ of the capacitor selection circuit are OFF, so $C1$ is discharged through $D1$ and the output voltage of the capacitor selection circuit is $V_{dc}/3$. $S1$ and $S4$ of the full-bridge power converter are ON. At this point, the output voltage of the seven-level inverter is directly equal to the output voltage of the capacitor selection circuit, which means the output voltage of the seven-level inverter is $V_{dc}/3$.

Mode 2: The operation of mode 2 is shown in Fig. 3(b). In the capacitor selection circuit, $SS1$ is OFF and $SS2$ is ON, so $C2$ is discharged through $SS2$ and $D2$ and the output voltage of the capacitor selection circuit is $2V_{dc}/3$. $S1$ and $S4$ of the full-bridge Power converter are ON. At this point, the output voltage of the seven-level inverter is $2V_{dc}/3$.

Mode 3: The operation of mode 3 is shown in Fig.3(c). In the Capacitor selection circuit, $SS1$ is ON. Since $D2$ has a reverse bias when $SS1$ is ON, the state of $SS2$ cannot affect the current flow. Therefore, $SS2$ may be ON or OFF, to avoiding switching of $SS2$. Both $C1$ and $C2$ are discharged in series and the output voltage of the capacitor selection circuit is V_{dc} . $S1$ and $S4$ of the full-bridge power converter are ON. At this point, the output voltage of the seven-level inverter is V_{dc} .

Mode 4: The operation of mode 4 is shown in Fig. 3(d). Both $SS1$ and $SS2$ of the capacitor selection circuit are OFF. The output voltage of the capacitor selection circuit is $V_{dc}/3$. Only $S4$ of the full-bridge power converter is ON. Since the output current of the seven-level inverter is positive and passes through the filter inductor, it forces the antiparallel diode of $S2$ to be

switched ON for continuous conduction of the filter inductor current. At this point, the output voltage of the seven level inverter is zero.

positive half cycle						
	S_{S1}	S_{S2}	S_1	S_2	S_3	S_4
$ v_u < V_{dc}/3$	off	off	PWM	off	off	on
$2V_{dc}/3 > v_u > V_{dc}/3$	off	PWM	on	off	off	on
$ v_u > 2V_{dc}/3$	PWM	on	on	off	off	on
negative half cycle						
$ v_u < V_{dc}/3$	off	off	off	on	PWM	off
$2V_{dc}/3 > v_u > V_{dc}/3$	off	PWM	off	on	on	off
$ v_u > 2V_{dc}/3$	PWM	on	off	on	on	off

Table-I. States of power electronic switches for a seven level inverter.

FUZZY CONTROLLER

Fuzzy logic controller is used to reduce the rise time, settling time to almost negligible and also try to remove the time delay and inverted response. It works with uncertain and imprecise knowledge. It provides an approximate but effective means of describing the behavior of systems that are too complex, ill-defined, or not easily analysed mathematically. Fuzzy variables are processed using a system called a fuzzy logic controller. It involves fuzzifications, fuzzy inference, and fuzzification. The fuzzification process converts a crisp input value to a fuzzy value. The fuzzy inference is responsible for drawing conclusions from the knowledge base. The defuzzification process converts the fuzzy control actions into a crisp control action.

$E \downarrow CE \rightarrow$	NB	NS	ZE	PS	PB
NB	NB	NB	NS	NS	ZE
NS	NB	NS	NS	ZE	PS
ZE	NS	NS	ZE	PS	PS
PS	NS	ZE	PS	PS	PB
PB	ZE	PS	PS	PB	PB

Table II- Rule based fuzzy logic controller

Fuzzy logic idea is similar to the human being’s feeling and inference process. Unlike classical control strategy, which is a point-to-point control, fuzzy logic control is a range-to-point or range-to-range control. The output of a fuzzy controller is derived from fuzzifications of both inputs and outputs using the associated membership functions. A crisp input will be converted to the different members of the associated membership functions based on its value. From this point of view, the output of a fuzzy logic controller is based on its memberships of the different membership functions, which can be considered as a range of inputs.

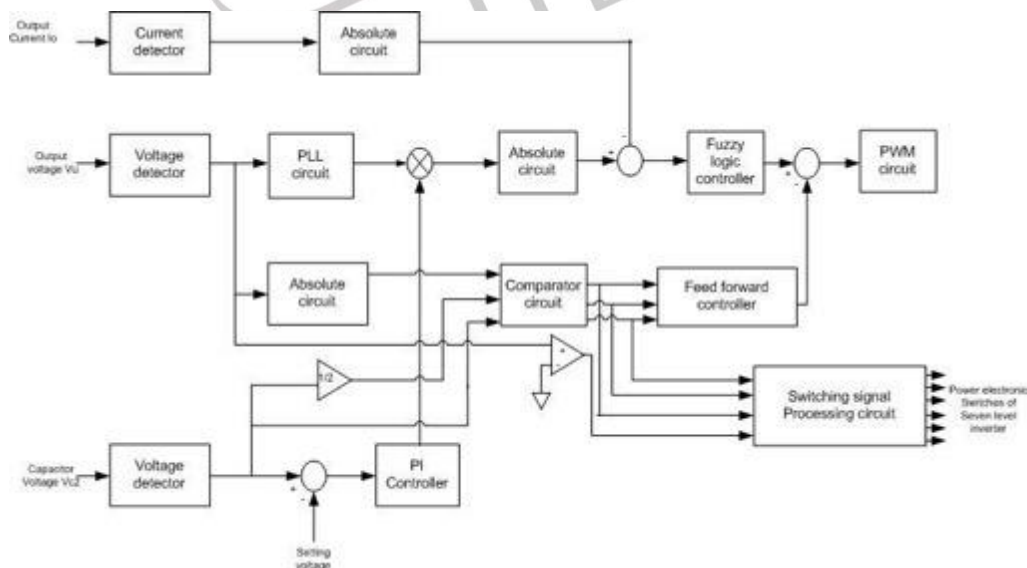

Fig.4. Control block diagram for the seven level inverter using fuzzy logic controller

Fuzzy ideas and fuzzy logic are so often utilized in our routine life that nobody even pays attention to them. For instance, to answer some questions in certain surveys, most time one could answer with 'Not Very Satisfied' or 'Quite Satisfied', which are

also fuzzy or ambiguous answers. Exactly to what degree is one satisfied or dissatisfied with some service or product for those surveys? These vague answers can only be created and implemented by human beings, but not machines. Is it possible for a computer to answer those survey questions directly as a human beings did? It is absolutely impossible. Computers can only understand either '0' or '1', and 'HIGH' or 'LOW'. Those data are called crisp or classic data and can be processed by all machines are shown in the table.

SIMULATION RESULTS

Model design and simulation are done in MATLAB SIMULINK, using fuzzy logic toolbox. The Sim power system tool box is essential for the proposed PV power generation system having only six power electronic switching for generating nine-level of output.

The simulation model of entire system along with its subsystem controlled by the fuzzy logic controller. With the lower number of switches the desire output are achieved and system is more compact. The input power may vary based on the PV insolation and according to which the dc/dc converter boost up the voltage along with its transformer. For the switches present in the boost converter and single H-bridge inverter, the PWM switching pulses are given.

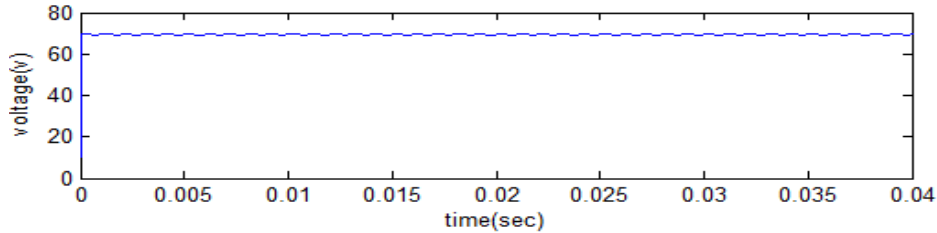

Fig.5. Shows the simulation result for PV output voltage changes from 40v to 70v by using the DC-DC power converter

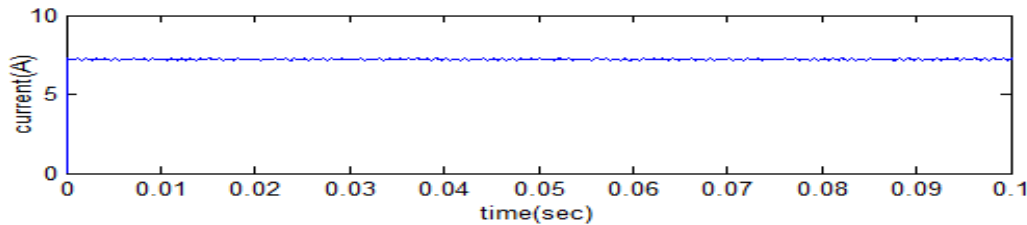

Fig.6. Simulation result for the PV output current.

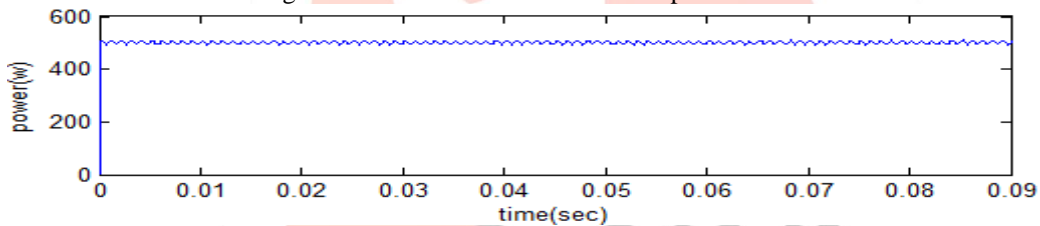

Fig.7. Simulation result for PV output power.

The power rating of the proposed system is 500w, at the voltage level 70v.

The output of the solar cell array is given to the input of the DC-DC boost converter. A ripple voltage with a frequency that is double that of the utility appears in the voltages in the voltages of C1 and C2, when the seven level inverter feeds real power into the utility.

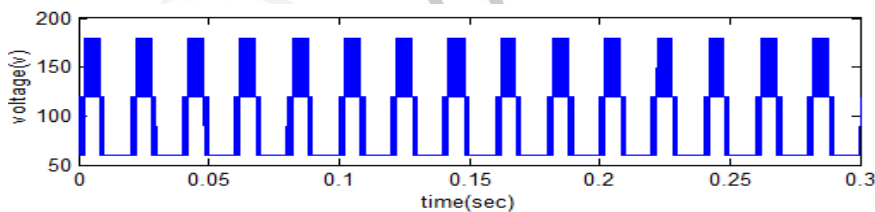

Fig.8. Simulation result for output voltage of the capacitor selection circuit has three voltage levels (60, 120, 180v).

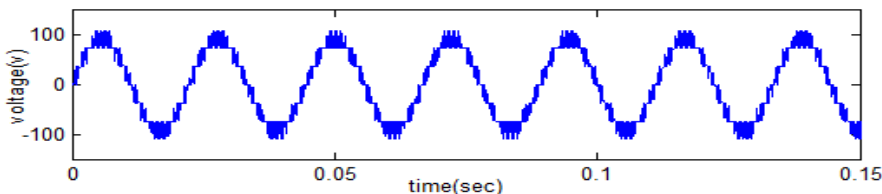

Fig.9. Simulation result for the output voltage of seven level inverter.

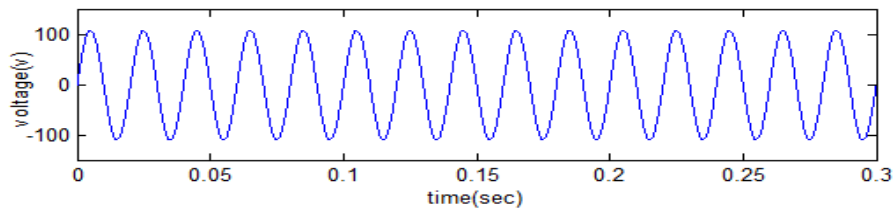

Fig.10. Simulation result for the obtained utility voltage.

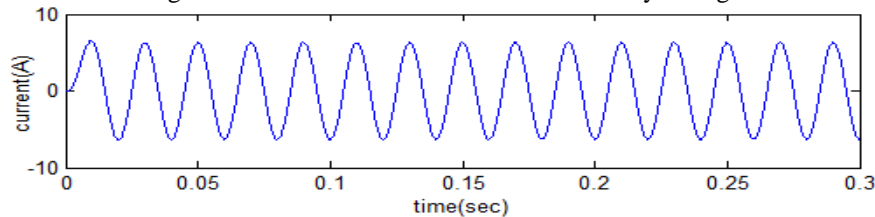

Fig.11. Simulation result for the obtained utility current.

The obtained result in proposed paper through simulation was used for a single phase utility with 110v and the power rating is 500w.

CONCLUSION

The proposed technique has some features such as it reduces the cost of the overall system, compact size as well as an increased efficiency. With the help of lower number of switches, seven-level of output voltages are generated and thus it reduces the switching loss and conduction losses. The THD of seven-level inverter is less compare to the five-level and three-level inverter. The fuzzy logic controller could control the switches present in the boost converter and H-bridge inverter. For the seven level of output, only six power electronic switches are used and only one switch will operate at high frequency at any time. For further implementation, the inverter level can extend by cascading additional H-bridge inverter. There may be some loss due to the transformer and this can also overcome by providing transformer less connection with its replacement. As the inverter level increases, the filter requirements and harmonic content decreases.

REFERENCES

- [1] Jinn-Chang Wu, Member, IEEE, and Chia-Wei Chou, —A Solar Power Generation System With a Seven-Level Inverter,| IEEE Trans. Power Electron., vol. 29,no. 7, pp. 3454–3462, July. 2014.
- [2] Fan Zhang, Kary Thanapalan, Andrew Procter, Stephen Carr, and Jon Maddy, —Adaptive Hybrid Maximum Power Point Tracking Method for a Photovoltaic System| IEEE Trans. Energy Conversion, vol. 28, no. 2, pp.353-360, June. 2013.
- [3] J. D. Barros, J. F. A. Silva, and E.G.A Jesus, —Fast-predictive optimal control of NPC multilevel converters,| IEEE Trans. Ind. Electron., vol. 60, no. 2, pp. 619–627, Feb. 2013.
- [4] J. Chavarria, D. Biel, F. Guinjoan, C.Meza, and J. J. Negroni, —Energy balance control of PV cascaded multilevel grid-connected inverters under level-shifted and phase-shifted PWMs,| IEEE Trans. Ind. Electron., vol. 60, no. 1, pp. 98–111, Jan. 2013.
- [5] X. She, A. Q. Huang, T. Zhao, and G. Wang, —Coupling effect reduction of a voltage-balancing controller in single-phase cascaded multilevel converters,| IEEE Trans. Power Electron., vol. 27, no. 8, pp. 3530–3543, Aug. 2012.
- [6] S. Choi and M. Saeedifard, —Capacitor voltage balancing of flying capacitor multilevel converters by space vector PWM,| IEEE Trans. Power Delivery, vol. 27, no. 3, pp. 1154–1161, Jul. 2012.
- [7] R. A. Mastromauro, M. Liserre, and A. Dell' Aquila, —Control issues in single-stage photovoltaic systems: MPPT, current and voltage control,| IEEE Trans. Ind. Informat., vol. 8, no. 2, pp. 241–254, May. 2012.
- [8] L. Maharjan, T. Yamagishi, and H. Akagi, —Active-power control of individual converter cells for a battery energy storage system based on a multilevel cascade PWM converter,| IEEE Trans. Power Electron., vol. 27, no. 3, pp. 1099–1107, Mar. 2012.
- [9] N. A. Rahim, K. Chaniago, and J.Selvaraj, —Single-phase seven-level grid-connected inverter for photovoltaic system,| IEEE Trans. Ind. Electr., vol. 58, no. 6, pp. 2435–2443, Jun. 2011.
- [10] Huan-Liang Tsai, Ci-Siang Tu, and Yi-Jie Su, Member, —Development of Generalized Photovoltaic Model Using MATLAB/SIMULINK,| IAENG, WCECS, San Francisco, USA October 22 - 24, 2008.
- [11] Ravi, A., Manoharan, P.S., Vijay Anand, J.: ‘_Modeling and simulation of three phase multilevel inverter for grid connected photovoltaic systems’, Solar Energy, 2011, 85, pp. 2811-2818.
- [12] A Ravi, PS Manoharan, M Valan Rajkumar ‘_Harmonic Reduction of Three-Phase Multilevel Inverter for Grid Connected Photovoltaic System Using Closed Loop Switching Control’ 2012, International Review on Modelling & Simulations 5 (5), pp.1934-1942.